

CUTTING TOOLS FOR

# HOLEMAKING



# B

## B - HOLEMAKING

B - 368 | Drills code key

B - 370 | Nomenclature

B - 371 | Overview

B - 372 | **NEW** Multicut



B - 378 | Jet drills

B - 380 | **NEW** XCS drills

B - 404 | Integrex drills

B - 412 | Vortex drills

B - 418 | Trepanning drills

B - 422 | Inserts

B - 424 | Inserts code key

B - 428 | Spare Parts

B - 440 | Technical Data

B - 452 | Solid carbide drills

**DRILLS WITHOUT CARTRIDGE** Brocas sem Cartucho | Brocas sin Cartucho

**X M S**
**X C S**
**S C S**
**2 1 5**
**2 5**
**- 3 D**

 DC  
21.5 mm

 DCONMS  
25 mm

 LU  
3D

**T D S**
**T F D**

Drill group

**D H S**
**0 0 4 0**
**3 2**
**- 5 D**

Drill group

 DC  
40 mm

 DCONMS  
32 mm

 LU  
5D

**DRILLS WITH CARTRIDGE** Brocas com Cartucho | Brocas con Cartucho

**S C C**
**T D C**
**6 0 6 5**
**4 0**
**- 4 D**

 DCN  
60 mm

 DCX  
65 mm

 DCONMS  
40 mm

 LU  
4D

**D H C**

Drill group

## DRILLS CODE KEY

Sistema de codificação para brocas | Sistema de codificación para brocas

## VORTEX DRILLS Brocas Vortex | Brocas Vortex

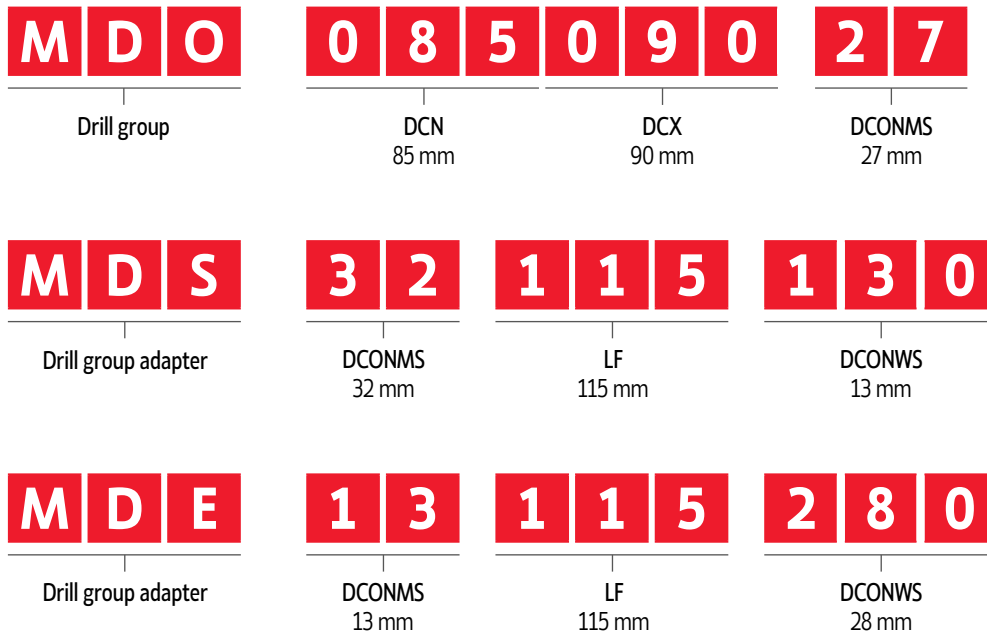

## TREPANNING DRILLS Brocas de Trepanação | Brocas de Trepanación

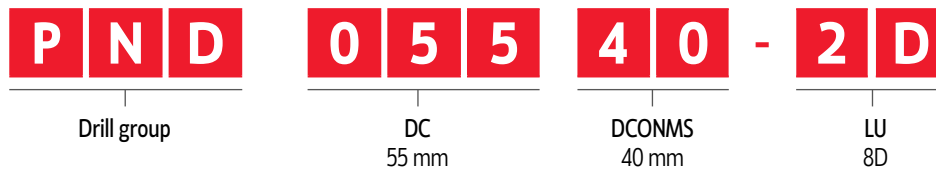

## SOLID CARBIDE DRILLS Brocas de Metal Duro | Brocas en Metal Duro

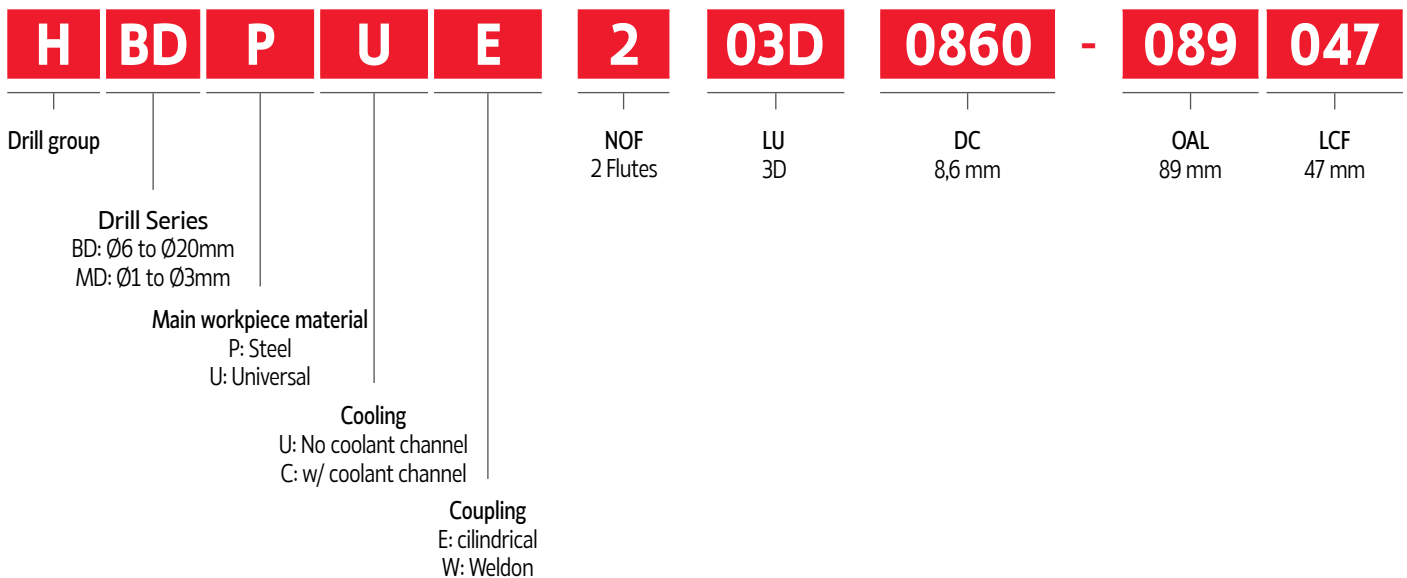

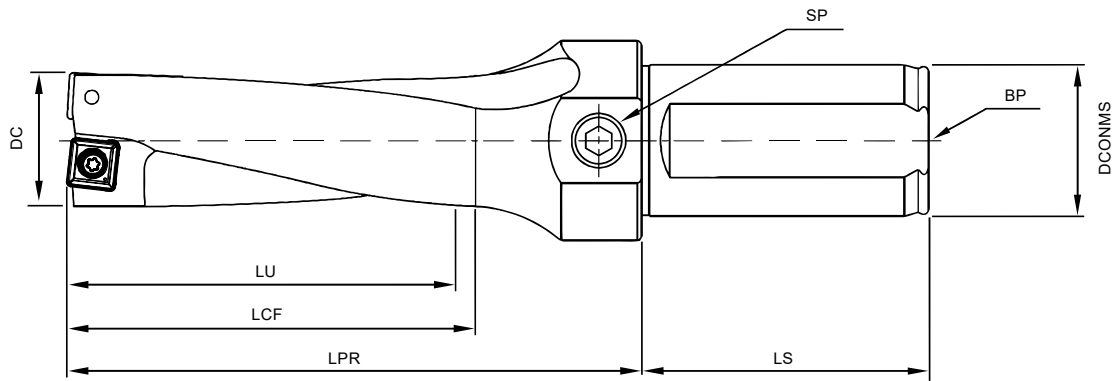

DC - Drill diameter

LPR - Length

LU - Cut length

SP - Side plug

DCONMS - Shank diameter

LS - Shank Length

LCF - Safety cut length

BP - Back plug

**COOLANT SUPPLY** Furos de refrigeração | Agujeros de refrigeración

New version / Standard version \*

| Type | BP    | SP    |
|------|-------|-------|
| TDS  | ✓ / ✓ | ✗ / ✓ |
| TDC  | ✓ / ✓ | ✓ / ✓ |
| SCS  | ✓ / ✓ | ✗ / ✓ |
| SCC  | ✓ / ✓ | ✓ / ✓ |
| DHS  | ✓ / ✓ | ✗ / ✓ |
| DHC  | ✓ / ✓ | ✗ / ✓ |
| TFD  | ✓ / ✓ | ✓ / ✓ |
| MDO  | ✓ / ✓ | ✓ / ✓ |
| PND  | ✓ / ✓ | ✓ / ✓ |





BP - Back Plug

SP - Side Plug

✓ - Available

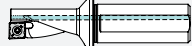
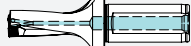
✗ - Not Available

\* The new Drill version will replace the standard version when this type will be sold out.

|                      |  | Diameter (mm) |    |  |    |    |    |    |  |   |     |         |
|----------------------|--|---------------|----|--|----|----|----|----|--|---|-----|---------|
|                      |  | 01            | 03 | 12   | 20 | 32 | 50 | 60 | 70   | 80  | 110 | ... 180 |
| Multicut             |  |               |    | <b>NEW</b> XMS-R/L (2.25D)<br><br>Page B - 374 LU max = 72mm          |    |    |    |    |  |   |     |         |
| Jet Drills           |  |               |    | <b>NEW</b> XCS Drill (2D-3D-4D-5D)<br><br>Page B - 380 LU max = 302mm |    |    |    |    |  |   |     |         |
|                      |  |               |    | SCS Drill (3D-4D)<br><br>Page B - 394 LU max = 200mm                  |    |    |    |    |  |   |     |         |
|                      |  |               |    |  |    |    |    |    | SCC Drill (3D-4D)<br><br>Page B - 398 LU max = 320mm |   |     |         |
|                      |  |               |    | TDS 3D Drill<br><br>Page B - 401 LU max = 174mm                       |    |    |    |    |  |   |     |         |
|                      |  |               |    |  |    |    |    |    |  | TDC 3D Drill<br><br>Page B - 403 LU max = 240mm |     |         |
| Integrex Drills      |  |               |    |  |    |    |    |    |  |   |     |         |
|                      |  |               |    |  |    |    |    |    |  |   |     |         |
|                      |  |               |    |  |    |    |    |    |  |   |     |         |
| Integrex Drills      |  |               |    |  |    |    |    |    |  |   |     |         |
|                      |  |               |    |  |    |    |    |    |  |   |     |         |
|                      |  |               |    |  |    |    |    |    |  |   |     |         |
| Vortex Drills        |  |               |    |  |    |    |    |    |  |   |     |         |
|                      |  |               |    |  |    |    |    |    |  |   |     |         |
| Trepanning Drills    |  |               |    |  |    |    |    |    |  |   |     |         |
|                      |  |               |    |  |    |    |    |    |  |   |     |         |
| Solid Carbide Drills |  |               |    |  |    |    |    |    |  |   |     |         |
|                      |  |               |    |  |    |    |    |    |  |   |     |         |
|                      |  |               |    |  |    |    |    |    |  |   |     |         |

Multicut

Jet Drills

Integrex Drills

Vortex Drills

Trepanning Drills

Inserts

Spare Parts

Technical Data

Solid Carbide Drills

# MULTICUT

**NEW** ALL-IN-ONE



A multipurpose tool designed to enhance productivity and reduce setup times is capable of executing internal, external, and face turning, as well as drilling with either a stationary or rotating tool.

Uma ferramenta multifuncional projetada para aumentar a produtividade e reduzir os tempos de configuração. Capaz de executar torneamento interno, externo e facejamento, e até mesmo furação com uma ferramenta estacionária ou giratória.

Una herramienta multifuncional diseñada para aumentar la productividad y reducir los tiempos de configuración. Capaz de realizar torneado interno, externo y frontal, e incluso perforación con una herramienta estacionaria o giratoria.

## **NEW XMS-R** > page 374

- > From DC 8mm to 32mm  
De DC 8mm a 32mm | Desde DC 8mm hasta 32mm
- > Available in 2.25D  
Disponível em 2.25D | Disponible en 2.25D



## **NEW XMS-L** > page 374

- > From DC 8mm to 32mm  
De DC de 8mm a 32mm | Desde DC 8mm hasta 32mm
- > Available in 2.25D  
Disponível em 2.25D | Disponible en 2.25D

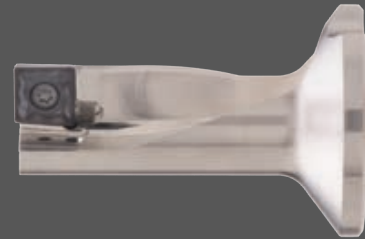

## **NEW XCMT INSERTS** > page 375

- > From sizes 04 to 17  
De tamanhos de 04 a 17 | De tamaños de 04 a 17
- > Available in grades PH7920 and PHS225  
Disponível nos graus PH7920 e PHS225 | Disponible en las calidades PH7920 y PHS225
- > Suitable for machining steels, stainless steels and HRSA  
Adequado para maquinação de aços, aços inoxidáveis e HRSA | Adequado para el mecanizado de aceros, aceros inoxidables y HRSA



# B NEW MULTICUT

HOLEMAKING

Multicut

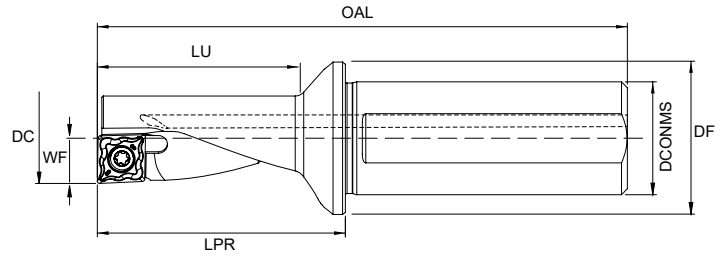

\*Right hand style show

| Order code<br>Código | Reference<br>Referência<br>Referencia | Hand  |   | Dimensions   Dimensões   Dimensiones (mm) |        |    |      |       |      |      | WT    | Insert         | Stock |
|----------------------|---------------------------------------|-------|---|---|--------|----|------|-------|------|------|-------|----------------|-------|
|                      |                                       |       |   | DC  | DCONMS | DF | WF   | OAL   | LU   | LPR  |       |                |       |
| 182021200            | XMS-R 08010-2.25D                     | Right | 1 | 8,0                                       | 10     | 15 | 4    | 60,0  | 18,0 | 22,0 | 0,027 | XCMT 0401.. ER |       |
| 182021300            | XMS-R 10012-2.25D                     | Right | 1 | 10,0                                      | 12     | 18 | 5    | 69,5  | 22,5 | 27,5 | 0,046 | XCMT 0502..    |       |
| 182021400            | XMS-R 12016-2.25D                     | Right | 1 | 12,0                                      | 16     | 22 | 6    | 78,0  | 27,0 | 33,0 | 0,089 | XCMT 0602..    |       |
| 182021500            | XMS-R 14016-2.25D                     | Right | 1 | 14,0                                      | 16     | 22 | 7    | 83,5  | 31,5 | 38,5 | 0,094 | XCMT 0703..    |       |
| 182021600            | XMS-R 16020-2.25D                     | Right | 1 | 16,0                                      | 20     | 28 | 8    | 94,0  | 36,0 | 44,0 | 0,154 | XCMT 0803..    |       |
| 182021700            | XMS-R 18025-2.25D                     | Right | 1 | 18,0                                      | 25     | 36 | 9    | 109,5 | 40,5 | 53,5 | 0,293 | XCMT 09T3..    |       |
| 182021800            | XMS-R 20025-2.25D                     | Right | 1 | 20,0                                      | 25     | 36 | 10   | 111,0 | 45,0 | 55,0 | 0,311 | XCMT 10T3..    |       |
| 182021900            | XMS-R 25032-2.25D                     | Right | 1 | 25,0                                      | 32     | 44 | 12,5 | 129,0 | 56,5 | 69,0 | 0,563 | XCMT 1304..    |       |
| 182022000            | XMS-R 32040-2.25D                     | Right | 1 | 32,0                                      | 40     | 54 | 16   | 158,0 | 72,0 | 88,0 | 1,117 | XCMT 1705..    |       |
| 182022100            | XMS-L 08010-2.25D                     | Left  | 1 | 8,0                                       | 10     | 15 | 4    | 60,0  | 18,0 | 22,0 | 0,027 | XCMT 0401.. EL |       |
| 182022200            | XMS-L 10012-2.25D                     | Left  | 1 | 10,0                                      | 12     | 18 | 5    | 69,5  | 22,5 | 27,5 | 0,046 | XCMT 0502..    |       |
| 182022300            | XMS-L 12016-2.25D                     | Left  | 1 | 12,0                                      | 16     | 22 | 6    | 78,0  | 27,0 | 33,0 | 0,089 | XCMT 0602..    |       |
| 182022400            | XMS-L 14016-2.25D                     | Left  | 1 | 14,0                                      | 16     | 22 | 7    | 83,5  | 31,5 | 38,5 | 0,094 | XCMT 0703..    |       |
| 182022500            | XMS-L 16020-2.25D                     | Left  | 1 | 16,0                                      | 20     | 28 | 8    | 94,0  | 36,0 | 44,0 | 0,154 | XCMT 0803..    |       |
| 182022600            | XMS-L 18025-2.25D                     | Left  | 1 | 18,0                                      | 25     | 36 | 9    | 109,5 | 40,5 | 53,5 | 0,293 | XCMT 09T3..    |       |
| 182022700            | XMS-L 20025-2.25D                     | Left  | 1 | 20,0                                      | 25     | 36 | 10   | 111,0 | 45,0 | 55,0 | 0,311 | XCMT 10T3..    |       |
| 182022800            | XMS-L 25032-2.25D                     | Left  | 1 | 25,0                                      | 32     | 44 | 12,5 | 129,0 | 56,5 | 69,0 | 0,563 | XCMT 1304..    |       |
| 182022900            | XMS-L 32040-2.25D                     | Left  | 1 | 32,0                                      | 40     | 54 | 16   | 158,0 | 72,0 | 88,0 | 1,117 | XCMT 1705..    |       |

Stock item | Produto de stock | Itens de stock

Available under request | Disponível sobre consulta | Disponible bajo consulta

Inserts

Spare Parts

Technical Data

Solid Carbide Drills

**XCMT** Inserts | Pastilhas | Plaquetas



XCMT-MP  
(PH7 grade)



XCMT-MP  
(PHS grade)

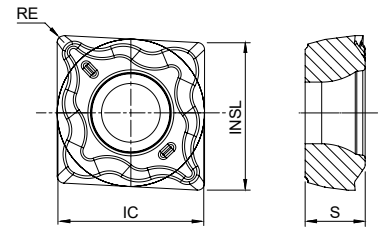

XCMT-MP

|                              |                           | P      | M      |        | S      | Dimensions   Dimensões   Dimensiones (mm) |      |       |      | Hand    |
|------------------------------|---------------------------|--------|--------|--------|--------|---|------|-------|------|---------|
|                              |                           | PVD    | CVD    | PVD    | PVD    | IC  | S    | INSL  | RE   |         |
|                              | <sup>(2)</sup> Grade code | G4     | U5     | G4     | G4     |   |      |       |      |         |
| <sup>(1)</sup> Geometry code | ISO Reference             | PH7920 | PHS225 | PH7920 | PH7920 |   |      |       |      |         |
| 1124790                      | XCMT 040104-MP ER         | ☑      | ☑      | ☑      | ☑      | 4,40                                      | 1,89 | 4,00  | 0,40 | Right   |
| 1124791                      | XCMT 040104-MP EL         | ☑      | ☑      | ☑      | ☑      | 4,40                                      | 1,89 | 4,00  | 0,40 | Left    |
| 1124792                      | XCMT 050204-MP EN         | ☑      | ☑      | ☑      | ☑      | 5,65                                      | 2,14 | 5,00  | 0,40 | Neutral |
| 1123788                      | XCMT 060204-MP EN         | ☑      | ☑      | ☑      | ☑      | 6,40                                      | 2,47 | 6,00  | 0,40 | Neutral |
| 1124784                      | XCMT 070304-MP EN         | ☑      | ☑      | ☑      | ☑      | 7,50                                      | 3,25 | 7,00  | 0,40 | Neutral |
| 1124785                      | XCMT 080304-MP EN         | ☑      | ☑      | ☑      | ☑      | 8,40                                      | 3,26 | 8,00  | 0,40 | Neutral |
| 1124786                      | XCMT 09T304-MP EN         | ☑      | ☑      | ☑      | ☑      | 9,45                                      | 4,00 | 9,00  | 0,40 | Neutral |
| 1124787                      | XCMT 10T308-MP EN         | ☑      | ☑      | ☑      | ☑      | 10,40                                     | 4,00 | 10,00 | 0,80 | Neutral |
| 1124788                      | XCMT 130408-MP EN         | ☑      | ☑      | ☑      | ☑      | 13,35                                     | 4,85 | 12,50 | 0,80 | Neutral |
| 1124789                      | XCMT 170508-MP EN         | ☑      | ☑      | ☑      | ☑      | 17,30                                     | 5,58 | 16,00 | 0,80 | Neutral |

☑ First choice | Primeira opção | 1ª opción    ☑ Stock item | Produto de stock | Itens de stock    ○ Available under request | Disponível sobre consulta | Disponible bajo consulta    Insert order code = (1) Geometry Code + (2) Grade Code

## SPARE PARTS Acessórios | Repuestos

| Cutter<br>ØDc       | Insert Screw | Key (Torx) | Order separately |              |
|---------------------|--------------|------------|------------------|--------------|
|                     |              |            | Key (Torx - Nm)  | Torque Value |
| XMS-R/L 08010-2.25D | P0180400     | XT06IP     | DT0606IP         | 0,60         |
| XMS-R/L 10012-2.25D | P0200500     | XT06       | DT0606           | 0,60         |
| XMS-R/L 12016-2.25D | P0220500     | XT07       | DT0709           | 0,90         |
| XMS-R/L 14016-2.25D | P0250704     | XT08       | DT0812           | 1,20         |
| XMS-R/L 16020-2.25D | P0300701     | XT08       | DT0812           | 1,20         |
| XMS-R/L 18025-2.25D | P0300701     | XT08       | DT0812           | 1,20         |
| XMS-R/L 20025-2.25D | P0350800     | PT15       | DT1530           | 3,00         |
| XMS-R/L 25032-2.25D | P0500900     | PT20       | DT2050           | 4,00         |
| XMS-R/L 32040-2.25D | P0501302     | PT20       | DT2050           | 4,00         |

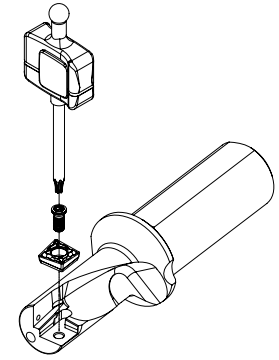

## GRADES SELECTION GUIDE Guia para selecção de graus | Tabla para selección de calidades

| ISO | PSM | Material                          | HB (Brinell) | Grades            |             |
|-----|-----|-----------------------------------|--------------|-------------------|-------------|
|     |     |                                   |              | ← Wear Resistance | Toughness → |
|     |     |                                   |              | PH7920            | PHS225      |
| P   | 1   | Unalloyed Steel                   | 125-170      | ●                 |             |
|     | 2   | Low-Alloyed Steel                 | 180-350      | ●                 |             |
|     | 3   | High-Alloyed Steel                | 200-325      | ●                 |             |
| M   | 4   | SS - Ferritic / Martensitic       | 200-330      | ●                 | ●           |
|     | 5   | SS - Austenitic                   | 180-330      | ●                 | ●           |
|     | 6   | SS - Austenitic-ferritic (Duplex) | 230-260      | ●                 | ●           |
| S   | 11  | Heat Resistant Super Alloys       | 200-320      | ●                 |             |

● Good Conditions
● Average Conditions
● Difficult Conditions

**RECOMMENDED CUTTING CONDITIONS** Condições de corte recomendadas | Condiciones de corte recomendables

| ISO | PSM | Material                          | HB (Brinell) | Vc (m/min)        |             |
|-----|-----|-----------------------------------|--------------|-------------------|-------------|
|     |     |                                   |              | ← Wear Resistance | Toughness → |
|     |     |                                   |              | PH7920            | PHS225      |
| P   | 1   | Unalloyed Steel                   | 125-170      | 110-220           | -           |
|     | 2   | Low-Alloyed Steel                 | 180-350      | 100-210           | -           |
|     | 3   | High-Alloyed Steel                | 200-325      | 85-190            | -           |
| M   | 4   | SS - Ferritic / Martensitic       | 200-330      | 95-210            | 70-230      |
|     | 5   | SS - Austenitic                   | 180-330      | 85-205            | 65-225      |
|     | 6   | SS - Austenitic-ferritic (Duplex) | 230-260      | 80-195            | 55-215      |
| S   | 11  | Heat Resistant Super Alloys       | 200-320      | 25-210            | -           |

| Reference           | FN (mm/rev)  |                 |            | AP (mm)      |                 |
|---------------------|--------------|-----------------|------------|--------------|-----------------|
|                     | Face Turning | Int/Ext Turning | Holemaking | Face Turning | Int/Ext Turning |
| XCMT 040104-MP ER/L | 0,02-0,09    | 0,02-0,13       | 0,01-0,04  | 0,50-1,90    | 0,50-2,70       |
| XCMT 050204-MP EN   | 0,02-0,12    | 0,02-0,15       | 0,01-0,05  | 0,50-2,20    | 0,50-3,20       |
| XCMT 060204-MP EN   | 0,02-0,14    | 0,02-0,16       | 0,01-0,06  | 0,70-2,70    | 0,70-3,70       |
| XCMT 070304-MP EN   | 0,02-0,16    | 0,02-0,18       | 0,01-0,08  | 0,80-3,00    | 0,80-4,00       |
| XCMT 080304-MP EN   | 0,03-0,18    | 0,03-0,20       | 0,02-0,08  | 0,90-3,40    | 0,90-4,20       |
| XCMT 09T304-MP EN   | 0,03-0,20    | 0,03-0,22       | 0,03-0,09  | 0,90-3,80    | 0,90-4,70       |
| XCMT 10T308-MP EN   | 0,03-0,22    | 0,03-0,24       | 0,03-0,10  | 1,00-4,20    | 1,00-5,30       |
| XCMT 130408-MP EN   | 0,03-0,24    | 0,03-0,26       | 0,04-0,12  | 1,00-5,00    | 1,00-6,50       |
| XCMT 170508-MP EN   | 0,03-0,27    | 0,03-0,30       | 0,04-0,15  | 1,00-6,00    | 1,00-7,00       |

**Off-center drilling:**

Thanks to MultiCut's unique geometry, it is possible to perform off-center drilling. Therefore, with slight deviations from the center of the workpiece, it is possible to make holes with diameters different from the nominal diameter, as shown in the table below.

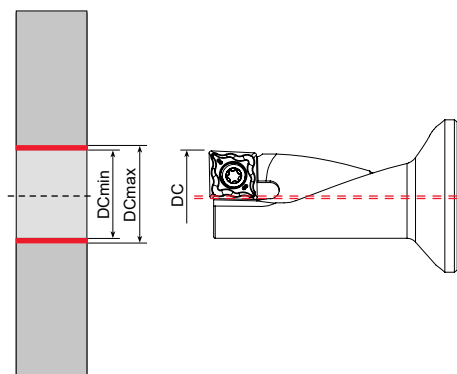

| Reference           | Drilling (mm) |                   |                   |
|---------------------|---------------|-------------------|-------------------|
|                     | DC nominal    | DC <sub>min</sub> | DC <sub>max</sub> |
| XMS-R/L 08010-2.25D | 8             | 7,85              | 8,30              |
| XMS-R/L 10012-2.25D | 10            | 9,85              | 10,50             |
| XMS-R/L 12016-2.25D | 12            | 11,85             | 12,50             |
| XMS-R/L 14016-2.25D | 14            | 13,80             | 14,50             |
| XMS-R/L 16020-2.25D | 16            | 15,80             | 16,50             |
| XMS-R/L 18025-2.25D | 18            | 17,80             | 18,50             |
| XMS-R/L 20025-2.25D | 20            | 19,75             | 20,50             |
| XMS-R/L 25032-2.25D | 25            | 24,75             | 25,80             |
| XMS-R/L 32040-2.25D | 32            | 31,75             | 33,00             |

# JET DRILLS



Jet drills provide an indexable insert solution for drilling across a wide range of diameters and cutting lengths, with or without cartridges. The innovative XCS drill demonstrates its versatility in drilling on any surface type, featuring dedicated chip breakers specially designed for steel, cast iron, stainless steel, and super alloys.

As brocas Jet oferecem uma solução de inserção indexável para perfurar numa ampla gama de diâmetros e comprimentos de corte, com ou sem cartuchos. A broca XCS demonstra versatilidade em qualquer tipo de superfície, apresentando quebra-aperas especialmente projetados para aço, ferro fundido, aço inoxidável e superligas.

Las brocas Jet proporcionan una solución de inserción indexable para la perforación en una amplia gama de diámetros y longitudes de corte, con o sin cartuchos. La broca XCS demuestra versatilidad en cualquier tipo de superficie, con rompevirutas especialmente diseñados para acero, hierro fundido, acero inoxidable y superaleaciones.

## **NEW XCS DRILL** > page 380

- > From DC 14,0mm to 60,0mm  
De DC 14mm a 60mm | Desde DC 14mm hasta 60mm
- > Available in 2D, 3D, 4D and 5D  
Disponível em 2D, 3D, 4D e 5D | Disponible en 2D, 3D, 4D y 5D
- > Inserts XOKX and SOKX  
Pastilhas XOKX e SOKX | Plaquetas XOKX y SOKX

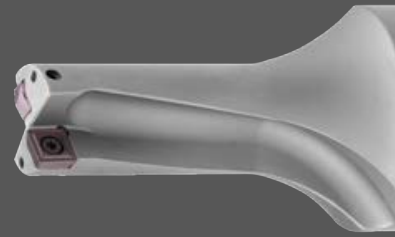

## **SCS DRILL** > page 394

- > From DC 13,0mm to 50,0mm  
De DC 13,0mm a 50,0mm | Desde DC 13,0mm hasta 50,0mm
- > Available in 3D and 4D  
Disponível em 3D e 4D | Disponible en 3D y 4D
- > Insert SPKX  
Pastilha SPKX | Plaqueta SPKX



## **SCC DRILL** > page 398

- > From DC 50mm to 80mm  
De DC 50mm a 80mm | Desde DC 50mm hasta 80mm
- > Available in 3D and 4D  
Disponível em 3D e 4D | Disponible en 3D y 4D
- > 2 SPKX inserts per cartridge  
2 pastilhas SPKX por cartucho | 2 plaquetas SPKX por cartucho

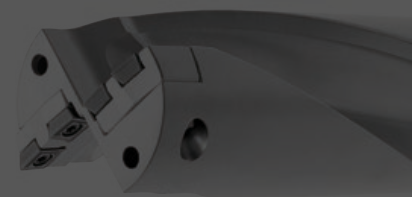

## **TDS DRILL** > page 401

- > From DC 13,0mm to 58,0mm  
De DC 13,0mm a 58,0mm | Desde DC 13,0mm hasta 58,0mm
- > Available in 3D  
Disponível em 3D | Disponible en 3D
- > Insert WCKX  
Pastilha WCKX | Plaqueta WCKX



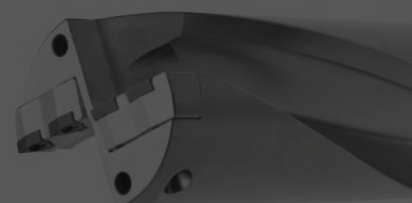

## **TDC DRILL** > page 403

- > From DC 59mm to 80mm  
De DC 59mm a 80mm | Desde DC 59mm hasta 80mm
- > Available in 3D  
Disponível em 3D | Disponible en 3D
- > 2 WCKX inserts per cartridge  
2 pastilhas WCKX por cartucho | 2 plaquetas WCKX por cartucho

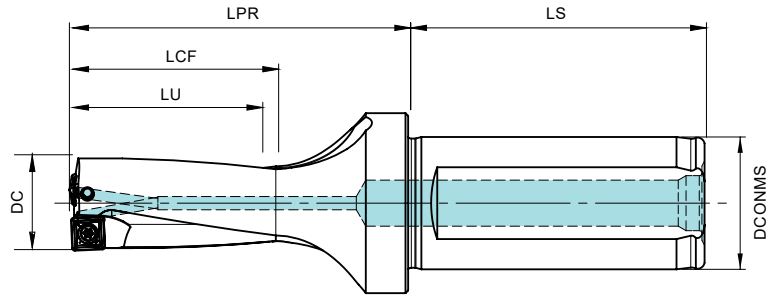



| DC | DCONMS | BP / SP  | 2D      |                 |                |
|----|--------|----------|---------|-----------------|----------------|
|    |        |          | DC      | Drill tolerance | Hole tolerance |
| 20 | 50     | PT - 1/8 | 14-29,5 | 0/-0,15         | -0,10/+0,20    |
| 25 | 56     | PT - 1/8 | 30-42   | 0/-0,15         | -0,10/+0,25    |
| 32 | 60     | PT - 1/4 | 43-60   | 0/-0,15         | -0,10/+0,28    |

| Order code<br>Código | Reference<br>Referência<br>Referencia | Dimensions   Dimensões   Dimensiones (mm) |        |    |     |     | Inner<br>Insert | Outer<br>Insert | Insert Screw<br> | Torx key<br> | Stock |
|----------------------|---------------------------------------|---|--------|----|-----|-----|-----------------|-----------------|--|--|-------|
|                      |                                       | DC  | DCONMS | LU | LCF | LPR |                 |                 |  |  |       |
| 184316800            | XCS 14020-2D                          | 14,0                                      | 20     | 28 | 31  | 51  | XOKX 050204     | SOKX 050204     | P02004IP   | XT06IP   | ☺     |
| 184316900            | XCS 14520-2D                          | 14,5                                      | 20     | 29 | 32  | 52  | XOKX 050204     | SOKX 050204     | P02004IP   | XT06IP   | ☺     |
| 184317000            | XCS 15020-2D                          | 15,0                                      | 20     | 30 | 33  | 53  | XOKX 050204     | SOKX 050204     | P02004IP   | XT06IP   | ☺     |
| 184317100            | XCS 15520-2D                          | 15,5                                      | 20     | 31 | 34  | 54  | XOKX 050204     | SOKX 050204     | P02004IP   | XT06IP   | ☺     |
| 184317200            | XCS 16020-2D                          | 16,0                                      | 20     | 32 | 35  | 55  | XOKX 050204     | SOKX 050204     | P02004IP   | XT06IP   | ☺     |
| 184317300            | XCS 16525-2D                          | 16,5                                      | 25     | 33 | 36  | 61  | XOKX 060204     | SOKX 060205     | P02205IP   | XT06IP   | ☺     |
| 184317400            | XCS 17025-2D                          | 17,0                                      | 25     | 34 | 37  | 62  | XOKX 060204     | SOKX 060205     | P02205IP   | XT06IP   | ☺     |
| 184317500            | XCS 17525-2D                          | 17,5                                      | 25     | 35 | 38  | 63  | XOKX 060204     | SOKX 060205     | P02205IP   | XT06IP   | ☺     |
| 184317600            | XCS 18025-2D                          | 18,0                                      | 25     | 36 | 39  | 64  | XOKX 060204     | SOKX 060205     | P02205IP   | XT06IP   | ☺     |
| 184317700            | XCS 18525-2D                          | 18,5                                      | 25     | 37 | 40  | 65  | XOKX 060204     | SOKX 060205     | P02205IP   | XT06IP   | ☺     |
| 184317800            | XCS 19025-2D                          | 19,0                                      | 25     | 38 | 41  | 66  | XOKX 060204     | SOKX 060205     | P02205IP   | XT06IP   | ☺     |
| 184317900            | XCS 19525-2D                          | 19,5                                      | 25     | 39 | 42  | 67  | XOKX 060204     | SOKX 060205     | P02205IP   | XT06IP   | ☺     |
| 184318000            | XCS 20025-2D                          | 20,0                                      | 25     | 40 | 43  | 68  | XOKX 07T205     | SOKX 07T208     | P02507IP   | XT08IP   | ☺     |
| 184318100            | XCS 20525-2D                          | 20,5                                      | 25     | 41 | 44  | 69  | XOKX 07T205     | SOKX 07T208     | P02507IP   | XT08IP   | ☺     |
| 184318200            | XCS 21025-2D                          | 21,0                                      | 25     | 42 | 45  | 70  | XOKX 07T205     | SOKX 07T208     | P02507IP   | XT08IP   | ☺     |
| 184318300            | XCS 21525-2D                          | 21,5                                      | 25     | 43 | 46  | 71  | XOKX 07T205     | SOKX 07T208     | P02507IP   | XT08IP   | ☺     |
| 184318400            | XCS 22025-2D                          | 22,0                                      | 25     | 44 | 47  | 72  | XOKX 07T205     | SOKX 07T208     | P02507IP   | XT08IP   | ☺     |
| 184318500            | XCS 22525-2D                          | 22,5                                      | 25     | 45 | 48  | 73  | XOKX 07T205     | SOKX 07T208     | P02507IP   | XT08IP   | ☺     |
| 184318600            | XCS 23025-2D                          | 23,0                                      | 25     | 46 | 49  | 74  | XOKX 07T205     | SOKX 07T208     | P02507IP   | XT08IP   | ☺     |
| 184318700            | XCS 23525-2D                          | 23,5                                      | 25     | 47 | 50  | 75  | XOKX 07T205     | SOKX 07T208     | P02507IP   | XT08IP   | ☺     |



☺ Stock item | Produto de stock | Itens de stock

○ Available under request | Disponível sobre consulta | Disponible bajo consulta

Continue next page

**XCS 2D**

Jet drills | Brocas jet | Brocas jet



| Order code<br>Código | Reference<br>Referência<br>Referencia | Dimensions   Dimensões   Dimensiones (mm) |        |     |     |     | Inner<br>Insert | Outer<br>Insert | Insert Screw<br> | Torx key<br> | Stock |
|----------------------|---------------------------------------|---|--------|-----|-----|-----|-----------------|-----------------|---|---|-------|
|                      |                                       | DC  | DCONMS | LU  | LCF | LPR |                 |                 |   |   |       |
| 184318800            | XCS 24032-2D                          | 24,0                                      | 32     | 48  | 51  | 81  | XOKX 090305     | SOKX 090308     | P03007IP  | XT08IP  | 📦     |
| 184318900            | XCS 24532-2D                          | 24,5                                      | 32     | 49  | 52  | 82  | XOKX 090305     | SOKX 090308     | P03007IP  | XT08IP  | 📦     |
| 184319000            | XCS 25032-2D                          | 25,0                                      | 32     | 50  | 53  | 83  | XOKX 090305     | SOKX 090308     | P03007IP  | XT08IP  | 📦     |
| 184319100            | XCS 25532-2D                          | 25,5                                      | 32     | 51  | 54  | 84  | XOKX 090305     | SOKX 090308     | P03007IP  | XT08IP  | 📦     |
| 184319200            | XCS 26032-2D                          | 26,0                                      | 32     | 52  | 55  | 85  | XOKX 090305     | SOKX 090308     | P03007IP  | XT08IP  | 📦     |
| 184319300            | XCS 26532-2D                          | 26,5                                      | 32     | 53  | 56  | 86  | XOKX 090305     | SOKX 090308     | P03007IP  | XT08IP  | 📦     |
| 184319400            | XCS 27032-2D                          | 27,0                                      | 32     | 54  | 57  | 87  | XOKX 090305     | SOKX 090308     | P03007IP  | XT08IP  | 📦     |
| 184319500            | XCS 27532-2D                          | 27,5                                      | 32     | 55  | 58  | 88  | XOKX 090305     | SOKX 090308     | P03007IP  | XT08IP  | 📦     |
| 184319600            | XCS 28032-2D                          | 28,0                                      | 32     | 56  | 59  | 89  | XOKX 090305     | SOKX 090308     | P03007IP  | XT08IP  | 📦     |
| 184319700            | XCS 28532-2D                          | 28,5                                      | 32     | 57  | 60  | 90  | XOKX 090305     | SOKX 090308     | P03007IP  | XT08IP  | 📦     |
| 184319800            | XCS 29032-2D                          | 29,0                                      | 32     | 58  | 61  | 91  | XOKX 090305     | SOKX 090308     | P03007IP  | XT08IP  | 📦     |
| 184319900            | XCS 29532-2D                          | 29,5                                      | 32     | 59  | 62  | 92  | XOKX 090305     | SOKX 090308     | P03007IP  | XT08IP  | 📦     |
| 184320000            | XCS 30032-2D                          | 30,0                                      | 32     | 62  | 65  | 95  | XOKX 11T306     | SOKX 11T308     | P03508IP  | XT15IP-S35  | 📦     |
| 184320100            | XCS 31032-2D                          | 31,0                                      | 32     | 64  | 67  | 97  | XOKX 11T306     | SOKX 11T308     | P03508IP  | XT15IP-S35  | 📦     |
| 184320200            | XCS 32032-2D                          | 32,0                                      | 32     | 66  | 69  | 99  | XOKX 11T306     | SOKX 11T308     | P03508IP  | XT15IP-S35  | 📦     |
| 184320300            | XCS 33032-2D                          | 33,0                                      | 32     | 68  | 71  | 101 | XOKX 11T306     | SOKX 11T308     | P03508IP  | XT15IP-S35  | 📦     |
| 184320400            | XCS 34032-2D                          | 34,0                                      | 32     | 70  | 73  | 103 | XOKX 11T306     | SOKX 11T308     | P03508IP  | XT15IP-S35  | 📦     |
| 184320500            | XCS 35032-2D                          | 35,0                                      | 32     | 72  | 75  | 105 | XOKX 11T306     | SOKX 11T308     | P03508IP  | XT15IP-S35  | 📦     |
| 184320600            | XCS 36040-2D                          | 36,0                                      | 40     | 74  | 77  | 112 | XOKX 130406     | SOKX 130410     | P04010IP  | XT15IP-S35  | 📦     |
| 184320700            | XCS 37040-2D                          | 37,0                                      | 40     | 76  | 79  | 114 | XOKX 130406     | SOKX 130410     | P04010IP  | XT15IP-S35  | 📦     |
| 184320800            | XCS 38040-2D                          | 38,0                                      | 40     | 78  | 81  | 116 | XOKX 130406     | SOKX 130410     | P04010IP  | XT15IP-S35  | 📦     |
| 184320900            | XCS 39040-2D                          | 39,0                                      | 40     | 80  | 83  | 118 | XOKX 130406     | SOKX 130410     | P04010IP  | XT15IP-S35  | 📦     |
| 184321000            | XCS 40040-2D                          | 40,0                                      | 40     | 82  | 85  | 120 | XOKX 130406     | SOKX 130410     | P04010IP  | XT15IP-S35  | 📦     |
| 184321100            | XCS 41040-2D                          | 41,0                                      | 40     | 84  | 87  | 122 | XOKX 130406     | SOKX 130410     | P04010IP  | XT15IP-S35  | 📦     |
| 184321200            | XCS 42040-2D                          | 42,0                                      | 40     | 86  | 89  | 124 | XOKX 130406     | SOKX 130410     | P04010IP  | XT15IP-S35  | 📦     |
| 184321300            | XCS 43040-2D                          | 43,0                                      | 40     | 88  | 91  | 126 | XOKX 150508     | SOKX 150510     | P05013IP  | XT20IP-S40  | 📦     |
| 184321400            | XCS 44040-2D                          | 44,0                                      | 40     | 90  | 93  | 128 | XOKX 150508     | SOKX 150510     | P05013IP  | XT20IP-S40  | 📦     |
| 184321500            | XCS 45040-2D                          | 45,0                                      | 40     | 92  | 95  | 130 | XOKX 150508     | SOKX 150510     | P05013IP  | XT20IP-S40  | 📦     |
| 184321600            | XCS 46040-2D                          | 46,0                                      | 40     | 94  | 97  | 132 | XOKX 150508     | SOKX 150510     | P05013IP  | XT20IP-S40  | 📦     |
| 184321700            | XCS 47040-2D                          | 47,0                                      | 40     | 96  | 99  | 134 | XOKX 150508     | SOKX 150510     | P05013IP  | XT20IP-S40  | 📦     |
| 184321800            | XCS 48040-2D                          | 48,0                                      | 40     | 98  | 101 | 136 | XOKX 150508     | SOKX 150510     | P05013IP  | XT20IP-S40  | 📦     |
| 184321900            | XCS 49040-2D                          | 49,0                                      | 40     | 100 | 103 | 138 | XOKX 150508     | SOKX 150510     | P05013IP  | XT20IP-S40  | 📦     |
| 184322000            | XCS 50040-2D                          | 50,0                                      | 40     | 102 | 105 | 140 | XOKX 150508     | SOKX 150510     | P05013IP  | XT20IP-S40  | 📦     |
| 184340200            | XCS 51040-2D                          | 51,0                                      | 40     | 104 | 107 | 142 | XOKX 180508     | SOKX 180510     | P05013IP  | XT20IP-S40  | 📦     |
| 184340300            | XCS 52040-2D                          | 52,0                                      | 40     | 106 | 109 | 144 | XOKX 180508     | SOKX 180510     | P05013IP  | XT20IP-S40  | 📦     |
| 184340400            | XCS 53040-2D                          | 53,0                                      | 40     | 108 | 111 | 146 | XOKX 180508     | SOKX 180510     | P05013IP  | XT20IP-S40  | 📦     |
| 184340500            | XCS 54040-2D                          | 54,0                                      | 40     | 110 | 113 | 148 | XOKX 180508     | SOKX 180510     | P05013IP  | XT20IP-S40  | 📦     |
| 184340600            | XCS 55040-2D                          | 55,0                                      | 40     | 112 | 115 | 150 | XOKX 180508     | SOKX 180510     | P05013IP  | XT20IP-S40  | 📦     |
| 184340700            | XCS 56040-2D                          | 56,0                                      | 40     | 114 | 117 | 152 | XOKX 180508     | SOKX 180510     | P05013IP  | XT20IP-S40  | 📦     |
| 184340800            | XCS 57040-2D                          | 57,0                                      | 40     | 116 | 119 | 154 | XOKX 180508     | SOKX 180510     | P05013IP  | XT20IP-S40  | 📦     |
| 184340900            | XCS 58040-2D                          | 58,0                                      | 40     | 118 | 121 | 156 | XOKX 180508     | SOKX 180510     | P05013IP  | XT20IP-S40  | 📦     |
| 184341000            | XCS 59040-2D                          | 59,0                                      | 40     | 120 | 123 | 158 | XOKX 180508     | SOKX 180510     | P05013IP  | XT20IP-S40  | 📦     |
| 184341100            | XCS 60040-2D                          | 60,00                                     | 40     | 122 | 125 | 160 | XOKX 180508     | SOKX 180510     | P05013IP  | XT20IP-S40  | 📦     |

📦 Stock item | Produto de stock | Itens de stock

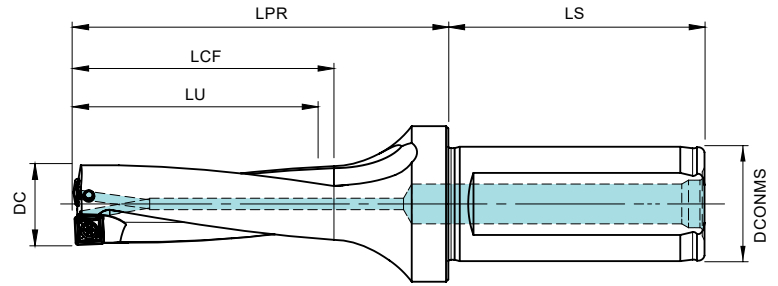
○ Available under request | Disponível sobre consulta | Disponible bajo consulta



| DC | DCONMS | BP / SP  | 3D      |                 |                |
|----|--------|----------|---------|-----------------|----------------|
|    |        |          | DC      | Drill tolerance | Hole tolerance |
| 20 | 50     | PT - 1/8 | 14-29,5 | 0/-0,15         | -0,10/+0,20    |
| 25 | 56     | PT - 1/8 | 30-42   | 0/-0,15         | -0,10/+0,25    |
| 32 | 60     | PT - 1/4 | 43-60   | 0/-0,15         | -0,10/+0,28    |

| Order code<br>Código | Reference<br>Referência<br>Referencia | Dimensions   Dimensões   Dimensiones (mm) |        |    |     |     | Inner<br>Insert | Outer<br>Insert | Insert Screw<br> | Torx key<br> | Stock |
|----------------------|---------------------------------------|---|--------|----|-----|-----|-----------------|-----------------|--|--|-------|
|                      |                                       | DC  | DCONMS | LU | LCF | LPR |                 |                 |  |  |       |
| 184322100            | XCS 14020-3D                          | 14,0                                      | 20     | 42 | 45  | 65  | XOKX 050204     | SOKX 050204     | P02004IP   | XT06IP   | ☺     |
| 184322200            | XCS 14520-3D                          | 14,5                                      | 20     | 44 | 47  | 67  | XOKX 050204     | SOKX 050204     | P02004IP   | XT06IP   | ☺     |
| 184322300            | XCS 15020-3D                          | 15,0                                      | 20     | 45 | 48  | 68  | XOKX 050204     | SOKX 050204     | P02004IP   | XT06IP   | ☺     |
| 184322400            | XCS 15520-3D                          | 15,5                                      | 20     | 47 | 50  | 70  | XOKX 050204     | SOKX 050204     | P02004IP   | XT06IP   | ☺     |
| 184322500            | XCS 16020-3D                          | 16,0                                      | 20     | 48 | 51  | 71  | XOKX 050204     | SOKX 050204     | P02004IP   | XT06IP   | ☺     |
| 184322600            | XCS 16525-3D                          | 16,5                                      | 25     | 50 | 53  | 78  | XOKX 060204     | SOKX 060205     | P02205IP   | XT06IP   | ☺     |
| 184322700            | XCS 17025-3D                          | 17,0                                      | 25     | 51 | 54  | 79  | XOKX 060204     | SOKX 060205     | P02205IP   | XT06IP   | ☺     |
| 184322800            | XCS 17525-3D                          | 17,5                                      | 25     | 53 | 56  | 81  | XOKX 060204     | SOKX 060205     | P02205IP   | XT06IP   | ☺     |
| 184322900            | XCS 18025-3D                          | 18,0                                      | 25     | 54 | 57  | 82  | XOKX 060204     | SOKX 060205     | P02205IP   | XT06IP   | ☺     |
| 184323000            | XCS 18525-3D                          | 18,5                                      | 25     | 56 | 59  | 84  | XOKX 060204     | SOKX 060205     | P02205IP   | XT06IP   | ☺     |
| 184323100            | XCS 19025-3D                          | 19,0                                      | 25     | 57 | 60  | 85  | XOKX 060204     | SOKX 060205     | P02205IP   | XT06IP   | ☺     |
| 184323200            | XCS 19525-3D                          | 19,5                                      | 25     | 59 | 62  | 87  | XOKX 060204     | SOKX 060205     | P02205IP   | XT06IP   | ☺     |
| 184323300            | XCS 20025-3D                          | 20,0                                      | 25     | 60 | 63  | 88  | XOKX 07T205     | SOKX 07T208     | P02507IP   | XT08IP   | ☺     |
| 184323400            | XCS 20525-3D                          | 20,5                                      | 25     | 62 | 65  | 90  | XOKX 07T205     | SOKX 07T208     | P02507IP   | XT08IP   | ☺     |
| 184323500            | XCS 21025-3D                          | 21,0                                      | 25     | 63 | 66  | 91  | XOKX 07T205     | SOKX 07T208     | P02507IP   | XT08IP   | ☺     |
| 184323600            | XCS 21525-3D                          | 21,5                                      | 25     | 65 | 68  | 93  | XOKX 07T205     | SOKX 07T208     | P02507IP   | XT08IP   | ☺     |
| 184323700            | XCS 22025-3D                          | 22,0                                      | 25     | 66 | 69  | 94  | XOKX 07T205     | SOKX 07T208     | P02507IP   | XT08IP   | ☺     |
| 184323800            | XCS 22525-3D                          | 22,5                                      | 25     | 68 | 71  | 96  | XOKX 07T205     | SOKX 07T208     | P02507IP   | XT08IP   | ☺     |
| 184323900            | XCS 23025-3D                          | 23,0                                      | 25     | 69 | 72  | 97  | XOKX 07T205     | SOKX 07T208     | P02507IP   | XT08IP   | ☺     |
| 184324000            | XCS 23525-3D                          | 23,5                                      | 25     | 71 | 74  | 99  | XOKX 07T205     | SOKX 07T208     | P02507IP   | XT08IP   | ☺     |



☺ Stock item | Produto de stock | Itens de stock

○ Available under request | Disponível sobre consulta | Disponible bajo consulta

Continue next page

# XCS 3D

Jet drills | Brocas jet | Brocas jet



| Order code<br>Código | Reference<br>Referência<br>Referencia | Dimensions   Dimensões   Dimensiones (mm) |        |     |     |     | Inner<br>Insert | Outer<br>Insert | Insert Screw<br> | Torx key<br> | Stock |
|----------------------|---------------------------------------|---|--------|-----|-----|-----|-----------------|-----------------|---|---|-------|
|                      |                                       | DC  | DCONMS | LU  | LCF | LPR |                 |                 |   |   |       |
| 184324100            | XCS 24032-3D                          | 24,0                                      | 32     | 72  | 75  | 105 | XOKX 090305     | SOKX 090308     | P03007IP  | XT08IP  | 📦     |
| 184324200            | XCS 24532-3D                          | 24,5                                      | 32     | 74  | 77  | 107 | XOKX 090305     | SOKX 090308     | P03007IP  | XT08IP  | 📦     |
| 184324300            | XCS 25032-3D                          | 25,0                                      | 32     | 75  | 78  | 108 | XOKX 090305     | SOKX 090308     | P03007IP  | XT08IP  | 📦     |
| 184324400            | XCS 25532-3D                          | 25,5                                      | 32     | 77  | 80  | 110 | XOKX 090305     | SOKX 090308     | P03007IP  | XT08IP  | 📦     |
| 184324500            | XCS 26032-3D                          | 26,0                                      | 32     | 78  | 81  | 111 | XOKX 090305     | SOKX 090308     | P03007IP  | XT08IP  | 📦     |
| 184324600            | XCS 26532-3D                          | 26,5                                      | 32     | 80  | 83  | 113 | XOKX 090305     | SOKX 090308     | P03007IP  | XT08IP  | 📦     |
| 184324700            | XCS 27032-3D                          | 27,0                                      | 32     | 81  | 84  | 114 | XOKX 090305     | SOKX 090308     | P03007IP  | XT08IP  | 📦     |
| 184324800            | XCS 27532-3D                          | 27,5                                      | 32     | 83  | 86  | 116 | XOKX 090305     | SOKX 090308     | P03007IP  | XT08IP  | 📦     |
| 184324900            | XCS 28032-3D                          | 28,0                                      | 32     | 84  | 87  | 117 | XOKX 090305     | SOKX 090308     | P03007IP  | XT08IP  | 📦     |
| 184325000            | XCS 28532-3D                          | 28,5                                      | 32     | 86  | 89  | 119 | XOKX 090305     | SOKX 090308     | P03007IP  | XT08IP  | 📦     |
| 184325100            | XCS 29032-3D                          | 29,0                                      | 32     | 87  | 90  | 120 | XOKX 090305     | SOKX 090308     | P03007IP  | XT08IP  | 📦     |
| 184325200            | XCS 29532-3D                          | 29,5                                      | 32     | 89  | 92  | 122 | XOKX 090305     | SOKX 090308     | P03007IP  | XT08IP  | 📦     |
| 184325300            | XCS 30032-3D                          | 30,0                                      | 32     | 92  | 95  | 125 | XOKX 11T306     | SOKX 11T308     | P03508IP  | XT15IP-S35  | 📦     |
| 184325400            | XCS 31032-3D                          | 31,0                                      | 32     | 95  | 98  | 128 | XOKX 11T306     | SOKX 11T308     | P03508IP  | XT15IP-S35  | 📦     |
| 184325500            | XCS 32032-3D                          | 32,0                                      | 32     | 98  | 101 | 131 | XOKX 11T306     | SOKX 11T308     | P03508IP  | XT15IP-S35  | 📦     |
| 184325600            | XCS 33032-3D                          | 33,0                                      | 32     | 101 | 104 | 134 | XOKX 11T306     | SOKX 11T308     | P03508IP  | XT15IP-S35  | 📦     |
| 184325700            | XCS 34032-3D                          | 34,0                                      | 32     | 104 | 107 | 137 | XOKX 11T306     | SOKX 11T308     | P03508IP  | XT15IP-S35  | 📦     |
| 184325800            | XCS 35032-3D                          | 35,0                                      | 32     | 107 | 110 | 140 | XOKX 11T306     | SOKX 11T308     | P03508IP  | XT15IP-S35  | 📦     |
| 184325900            | XCS 36040-3D                          | 36,0                                      | 40     | 110 | 113 | 148 | XOKX 130406     | SOKX 130410     | P04010IP  | XT15IP-S35  | 📦     |
| 184326000            | XCS 37040-3D                          | 37,0                                      | 40     | 113 | 116 | 151 | XOKX 130406     | SOKX 130410     | P04010IP  | XT15IP-S35  | 📦     |
| 184326100            | XCS 38040-3D                          | 38,0                                      | 40     | 116 | 119 | 154 | XOKX 130406     | SOKX 130410     | P04010IP  | XT15IP-S35  | 📦     |
| 184326200            | XCS 39040-3D                          | 39,0                                      | 40     | 119 | 122 | 157 | XOKX 130406     | SOKX 130410     | P04010IP  | XT15IP-S35  | 📦     |
| 184326300            | XCS 40040-3D                          | 40,0                                      | 40     | 122 | 125 | 160 | XOKX 130406     | SOKX 130410     | P04010IP  | XT15IP-S35  | 📦     |
| 184326400            | XCS 41040-3D                          | 41,0                                      | 40     | 125 | 128 | 163 | XOKX 130406     | SOKX 130410     | P04010IP  | XT15IP-S35  | 📦     |
| 184326500            | XCS 42040-3D                          | 42,0                                      | 40     | 128 | 131 | 166 | XOKX 130406     | SOKX 130410     | P04010IP  | XT15IP-S35  | 📦     |
| 184326600            | XCS 43040-3D                          | 43,0                                      | 40     | 131 | 134 | 169 | XOKX 150508     | SOKX 150510     | P05013IP  | XT20IP-S40  | 📦     |
| 184326700            | XCS 44040-3D                          | 44,0                                      | 40     | 134 | 137 | 172 | XOKX 150508     | SOKX 150510     | P05013IP  | XT20IP-S40  | 📦     |
| 184310700            | XCS 45040-3D                          | 45,0                                      | 40     | 137 | 140 | 175 | XOKX 150508     | SOKX 150510     | P05013IP  | XT20IP-S40  | 📦     |
| 184310800            | XCS 46040-3D                          | 46,0                                      | 40     | 140 | 143 | 178 | XOKX 150508     | SOKX 150510     | P05013IP  | XT20IP-S40  | 📦     |
| 184326800            | XCS 47040-3D                          | 47,0                                      | 40     | 143 | 146 | 181 | XOKX 150508     | SOKX 150510     | P05013IP  | XT20IP-S40  | 📦     |
| 184326900            | XCS 48040-3D                          | 48,0                                      | 40     | 146 | 149 | 184 | XOKX 150508     | SOKX 150510     | P05013IP  | XT20IP-S40  | 📦     |
| 184327000            | XCS 49040-3D                          | 49,0                                      | 40     | 149 | 152 | 187 | XOKX 150508     | SOKX 150510     | P05013IP  | XT20IP-S40  | 📦     |
| 184327100            | XCS 50040-3D                          | 50,0                                      | 40     | 152 | 155 | 190 | XOKX 150508     | SOKX 150510     | P05013IP  | XT20IP-S40  | 📦     |
| 184341200            | XCS 51040-3D                          | 51,0                                      | 40     | 155 | 158 | 193 | XOKX 180508     | SOKX 180510     | P05013IP  | XT20IP-S40  | 📦     |
| 184341300            | XCS 52040-3D                          | 52,0                                      | 40     | 158 | 161 | 196 | XOKX 180508     | SOKX 180510     | P05013IP  | XT20IP-S40  | 📦     |
| 184341400            | XCS 53040-3D                          | 53,0                                      | 40     | 161 | 164 | 199 | XOKX 180508     | SOKX 180510     | P05013IP  | XT20IP-S40  | 📦     |
| 184341500            | XCS 54040-3D                          | 54,0                                      | 40     | 164 | 167 | 202 | XOKX 180508     | SOKX 180510     | P05013IP  | XT20IP-S40  | 📦     |
| 184341600            | XCS 55040-3D                          | 55,0                                      | 40     | 167 | 170 | 205 | XOKX 180508     | SOKX 180510     | P05013IP  | XT20IP-S40  | 📦     |
| 184341700            | XCS 56040-3D                          | 56,0                                      | 40     | 170 | 173 | 208 | XOKX 180508     | SOKX 180510     | P05013IP  | XT20IP-S40  | 📦     |
| 184341800            | XCS 57040-3D                          | 57,0                                      | 40     | 173 | 176 | 211 | XOKX 180508     | SOKX 180510     | P05013IP  | XT20IP-S40  | 📦     |
| 184341900            | XCS 58040-3D                          | 58,0                                      | 40     | 176 | 179 | 214 | XOKX 180508     | SOKX 180510     | P05013IP  | XT20IP-S40  | 📦     |
| 184342000            | XCS 59040-3D                          | 59,0                                      | 40     | 179 | 182 | 217 | XOKX 180508     | SOKX 180510     | P05013IP  | XT20IP-S40  | 📦     |
| 184342100            | XCS 60040-3D                          | 60,0                                      | 40     | 182 | 185 | 220 | XOKX 180508     | SOKX 180510     | P05013IP  | XT20IP-S40  | 📦     |

📦 Stock item | Produto de stock | Itens de stock

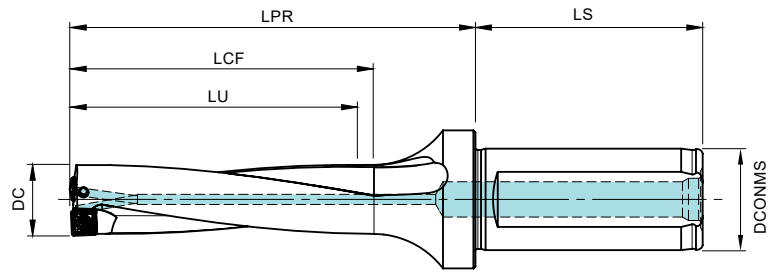
○ Available under request | Disponível sobre consulta | Disponible bajo consulta



| DC | DCONMS | BP / SP  | 4D      |                 |                |
|----|--------|----------|---------|-----------------|----------------|
|    |        |          | DC      | Drill tolerance | Hole tolerance |
| 20 | 50     | PT - 1/8 | 14-29,5 | 0/-0,15         | -0,05/+0,25    |
| 25 | 56     | PT - 1/8 | 30-42   | 0/-0,15         | -0,05/+0,30    |
| 32 | 60     | PT - 1/4 | 43-60   | 0/-0,15         | -0,05/+0,33    |

| Order code<br>Código | Reference<br>Referência<br>Referencia | Dimensions   Dimensões   Dimensiones (mm) |        |    |     |     | Inner<br>Insert | Outer<br>Insert | Insert Screw<br> | Torx key<br> | Stock |
|----------------------|---------------------------------------|---|--------|----|-----|-----|-----------------|-----------------|--|--|-------|
|                      |                                       | DC  | DCONMS | LU | LCF | LPR |                 |                 |  |  |       |
| 184327200            | XCS 14020-4D                          | 14,0                                      | 20     | 56 | 59  | 79  | XOKX 050204     | SOKX 050204     | P02004IP   | XT06IP   | ☺     |
| 184327300            | XCS 14520-4D                          | 14,5                                      | 20     | 58 | 61  | 81  | XOKX 050204     | SOKX 050204     | P02004IP   | XT06IP   | ☺     |
| 184327400            | XCS 15020-4D                          | 15,0                                      | 20     | 60 | 63  | 83  | XOKX 050204     | SOKX 050204     | P02004IP   | XT06IP   | ☺     |
| 184327500            | XCS 15520-4D                          | 15,5                                      | 20     | 62 | 65  | 85  | XOKX 050204     | SOKX 050204     | P02004IP   | XT06IP   | ☺     |
| 184327600            | XCS 16020-4D                          | 16,0                                      | 20     | 64 | 67  | 87  | XOKX 050204     | SOKX 050204     | P02004IP   | XT06IP   | ☺     |
| 184327700            | XCS 16525-4D                          | 16,5                                      | 25     | 66 | 69  | 94  | XOKX 060204     | SOKX 060205     | P02205IP   | XT06IP   | ☺     |
| 184327800            | XCS 17025-4D                          | 17,0                                      | 25     | 68 | 71  | 96  | XOKX 060204     | SOKX 060205     | P02205IP   | XT06IP   | ☺     |
| 184327900            | XCS 17525-4D                          | 17,5                                      | 25     | 70 | 73  | 98  | XOKX 060204     | SOKX 060205     | P02205IP   | XT06IP   | ☺     |
| 184328000            | XCS 18025-4D                          | 18,0                                      | 25     | 72 | 75  | 100 | XOKX 060204     | SOKX 060205     | P02205IP   | XT06IP   | ☺     |
| 184328100            | XCS 18525-4D                          | 18,5                                      | 25     | 74 | 77  | 102 | XOKX 060204     | SOKX 060205     | P02205IP   | XT06IP   | ☺     |
| 184328200            | XCS 19025-4D                          | 19,0                                      | 25     | 76 | 79  | 104 | XOKX 060204     | SOKX 060205     | P02205IP   | XT06IP   | ☺     |
| 184328300            | XCS 19525-4D                          | 19,5                                      | 25     | 78 | 81  | 106 | XOKX 060204     | SOKX 060205     | P02205IP   | XT06IP   | ☺     |
| 184328400            | XCS 20025-4D                          | 20,0                                      | 25     | 80 | 83  | 108 | XOKX 07T205     | SOKX 07T208     | P02507IP   | XT08IP   | ☺     |
| 184328500            | XCS 20525-4D                          | 20,5                                      | 25     | 82 | 85  | 110 | XOKX 07T205     | SOKX 07T208     | P02507IP   | XT08IP   | ☺     |
| 184328600            | XCS 21025-4D                          | 21,0                                      | 25     | 84 | 87  | 112 | XOKX 07T205     | SOKX 07T208     | P02507IP   | XT08IP   | ☺     |
| 184328700            | XCS 21525-4D                          | 21,5                                      | 25     | 86 | 89  | 114 | XOKX 07T205     | SOKX 07T208     | P02507IP   | XT08IP   | ☺     |
| 184328800            | XCS 22025-4D                          | 22,0                                      | 25     | 88 | 91  | 116 | XOKX 07T205     | SOKX 07T208     | P02507IP   | XT08IP   | ☺     |
| 184328900            | XCS 22525-4D                          | 22,5                                      | 25     | 90 | 93  | 118 | XOKX 07T205     | SOKX 07T208     | P02507IP   | XT08IP   | ☺     |
| 184329000            | XCS 23025-4D                          | 23,0                                      | 25     | 92 | 95  | 120 | XOKX 07T205     | SOKX 07T208     | P02507IP   | XT08IP   | ☺     |
| 184329100            | XCS 23525-4D                          | 23,5                                      | 25     | 94 | 97  | 122 | XOKX 07T205     | SOKX 07T208     | P02507IP   | XT08IP   | ☺     |



☺ Stock item | Produto de stock | Itens de stock

○ Available under request | Disponível sobre consulta | Disponible bajo consulta

Continue next page

# XCS 4D

Jet drills | Brocas jet | Brocas jet



| Order code<br>Código | Reference<br>Referência<br>Referencia | Dimensions   Dimensões   Dimensiones (mm) |        |     |     |     | Inner<br>Insert | Outer<br>Insert | Insert Screw<br> | Torx key<br> | Stock |
|----------------------|---------------------------------------|---|--------|-----|-----|-----|-----------------|-----------------|---|---|-------|
|                      |                                       | DC  | DCONMS | LU  | LCF | LPR |                 |                 |   |   |       |
| 184329200            | XCS 24032-4D                          | 24,0                                      | 32     | 96  | 99  | 129 | XOKX 090305     | SOKX 090308     | P03007IP  | XT08IP  | 📦     |
| 184329300            | XCS 24532-4D                          | 24,5                                      | 32     | 98  | 101 | 131 | XOKX 090305     | SOKX 090308     | P03007IP  | XT08IP  | 📦     |
| 184329400            | XCS 25032-4D                          | 25,0                                      | 32     | 100 | 103 | 133 | XOKX 090305     | SOKX 090308     | P03007IP  | XT08IP  | 📦     |
| 184329500            | XCS 25532-4D                          | 25,5                                      | 32     | 102 | 105 | 135 | XOKX 090305     | SOKX 090308     | P03007IP  | XT08IP  | 📦     |
| 184329600            | XCS 26032-4D                          | 26,0                                      | 32     | 104 | 107 | 137 | XOKX 090305     | SOKX 090308     | P03007IP  | XT08IP  | 📦     |
| 184329700            | XCS 26532-4D                          | 26,5                                      | 32     | 106 | 109 | 139 | XOKX 090305     | SOKX 090308     | P03007IP  | XT08IP  | 📦     |
| 184329800            | XCS 27032-4D                          | 27,0                                      | 32     | 108 | 111 | 141 | XOKX 090305     | SOKX 090308     | P03007IP  | XT08IP  | 📦     |
| 184329900            | XCS 27532-4D                          | 27,5                                      | 32     | 110 | 113 | 143 | XOKX 090305     | SOKX 090308     | P03007IP  | XT08IP  | 📦     |
| 184330000            | XCS 28032-4D                          | 28,0                                      | 32     | 112 | 115 | 145 | XOKX 090305     | SOKX 090308     | P03007IP  | XT08IP  | 📦     |
| 184330100            | XCS 28532-4D                          | 28,5                                      | 32     | 114 | 117 | 147 | XOKX 090305     | SOKX 090308     | P03007IP  | XT08IP  | 📦     |
| 184330200            | XCS 29032-4D                          | 29,0                                      | 32     | 116 | 119 | 149 | XOKX 090305     | SOKX 090308     | P03007IP  | XT08IP  | 📦     |
| 184330300            | XCS 29532-4D                          | 29,5                                      | 32     | 118 | 121 | 151 | XOKX 090305     | SOKX 090308     | P03007IP  | XT08IP  | 📦     |
| 184330400            | XCS 30032-4D                          | 30,0                                      | 32     | 122 | 125 | 155 | XOKX 11T306     | SOKX 11T308     | P03508IP  | XT15IP-S35  | 📦     |
| 184330500            | XCS 31032-4D                          | 31,0                                      | 32     | 126 | 129 | 159 | XOKX 11T306     | SOKX 11T308     | P03508IP  | XT15IP-S35  | 📦     |
| 184330600            | XCS 32032-4D                          | 32,0                                      | 32     | 130 | 133 | 163 | XOKX 11T306     | SOKX 11T308     | P03508IP  | XT15IP-S35  | 📦     |
| 184330700            | XCS 33032-4D                          | 33,0                                      | 32     | 134 | 137 | 167 | XOKX 11T306     | SOKX 11T308     | P03508IP  | XT15IP-S35  | 📦     |
| 184330800            | XCS 34032-4D                          | 34,0                                      | 32     | 138 | 141 | 171 | XOKX 11T306     | SOKX 11T308     | P03508IP  | XT15IP-S35  | 📦     |
| 184330900            | XCS 35032-4D                          | 35,0                                      | 32     | 142 | 145 | 175 | XOKX 11T306     | SOKX 11T308     | P03508IP  | XT15IP-S35  | 📦     |
| 184331000            | XCS 36040-4D                          | 36,0                                      | 40     | 146 | 149 | 184 | XOKX 130406     | SOKX 130410     | P04010IP  | XT15IP-S35  | 📦     |
| 184331100            | XCS 37040-4D                          | 37,0                                      | 40     | 150 | 153 | 188 | XOKX 130406     | SOKX 130410     | P04010IP  | XT15IP-S35  | 📦     |
| 184331200            | XCS 38040-4D                          | 38,0                                      | 40     | 154 | 157 | 192 | XOKX 130406     | SOKX 130410     | P04010IP  | XT15IP-S35  | 📦     |
| 184331300            | XCS 39040-4D                          | 39,0                                      | 40     | 158 | 161 | 196 | XOKX 130406     | SOKX 130410     | P04010IP  | XT15IP-S35  | 📦     |
| 184331400            | XCS 40040-4D                          | 40,0                                      | 40     | 162 | 165 | 200 | XOKX 130406     | SOKX 130410     | P04010IP  | XT15IP-S35  | 📦     |
| 184331500            | XCS 41040-4D                          | 41,0                                      | 40     | 166 | 169 | 204 | XOKX 130406     | SOKX 130410     | P04010IP  | XT15IP-S35  | 📦     |
| 184331600            | XCS 42040-4D                          | 42,0                                      | 40     | 170 | 173 | 208 | XOKX 130406     | SOKX 130410     | P04010IP  | XT15IP-S35  | 📦     |
| 184331700            | XCS 43040-4D                          | 43,0                                      | 40     | 174 | 177 | 212 | XOKX 150508     | SOKX 150510     | P05013IP  | XT20IP-S40  | 📦     |
| 184331800            | XCS 44040-4D                          | 44,0                                      | 40     | 178 | 181 | 216 | XOKX 150508     | SOKX 150510     | P05013IP  | XT20IP-S40  | 📦     |
| 184331900            | XCS 45040-4D                          | 45,0                                      | 40     | 182 | 185 | 220 | XOKX 150508     | SOKX 150510     | P05013IP  | XT20IP-S40  | 📦     |
| 184332000            | XCS 46040-4D                          | 46,0                                      | 40     | 186 | 189 | 224 | XOKX 150508     | SOKX 150510     | P05013IP  | XT20IP-S40  | 📦     |
| 184332100            | XCS 47040-4D                          | 47,0                                      | 40     | 190 | 193 | 228 | XOKX 150508     | SOKX 150510     | P05013IP  | XT20IP-S40  | 📦     |
| 184332200            | XCS 48040-4D                          | 48,0                                      | 40     | 194 | 197 | 232 | XOKX 150508     | SOKX 150510     | P05013IP  | XT20IP-S40  | 📦     |
| 184332300            | XCS 49040-4D                          | 49,0                                      | 40     | 198 | 201 | 236 | XOKX 150508     | SOKX 150510     | P05013IP  | XT20IP-S40  | 📦     |
| 184332400            | XCS 50040-4D                          | 50,0                                      | 40     | 202 | 205 | 240 | XOKX 150508     | SOKX 150510     | P05013IP  | XT20IP-S40  | 📦     |
| 184342200            | XCS 51040-4D                          | 51,0                                      | 40     | 204 | 209 | 244 | XOKX 180508     | SOKX 180510     | P05013IP  | XT20IP-S40  | 📦     |
| 184342300            | XCS 52040-4D                          | 52,0                                      | 40     | 208 | 213 | 248 | XOKX 180508     | SOKX 180510     | P05013IP  | XT20IP-S40  | 📦     |
| 184342400            | XCS 53040-4D                          | 53,0                                      | 40     | 212 | 217 | 252 | XOKX 180508     | SOKX 180510     | P05013IP  | XT20IP-S40  | 📦     |
| 184342500            | XCS 54040-4D                          | 54,0                                      | 40     | 216 | 221 | 256 | XOKX 180508     | SOKX 180510     | P05013IP  | XT20IP-S40  | 📦     |
| 184342600            | XCS 55040-4D                          | 55,0                                      | 40     | 220 | 225 | 260 | XOKX 180508     | SOKX 180510     | P05013IP  | XT20IP-S40  | 📦     |
| 184342700            | XCS 56040-4D                          | 56,0                                      | 40     | 224 | 229 | 264 | XOKX 180508     | SOKX 180510     | P05013IP  | XT20IP-S40  | 📦     |
| 184342800            | XCS 57040-4D                          | 57,0                                      | 40     | 228 | 233 | 264 | XOKX 180508     | SOKX 180510     | P05013IP  | XT20IP-S40  | 📦     |
| 184342900            | XCS 58040-4D                          | 58,0                                      | 40     | 232 | 237 | 272 | XOKX 180508     | SOKX 180510     | P05013IP  | XT20IP-S40  | 📦     |
| 184343000            | XCS 59040-4D                          | 59,0                                      | 40     | 236 | 241 | 276 | XOKX 180508     | SOKX 180510     | P05013IP  | XT20IP-S40  | 📦     |
| 184343100            | XCS 60040-4D                          | 60,0                                      | 40     | 240 | 245 | 280 | XOKX 180508     | SOKX 180510     | P05013IP  | XT20IP-S40  | 📦     |

📦 Stock item | Produto de stock | Itens de stock

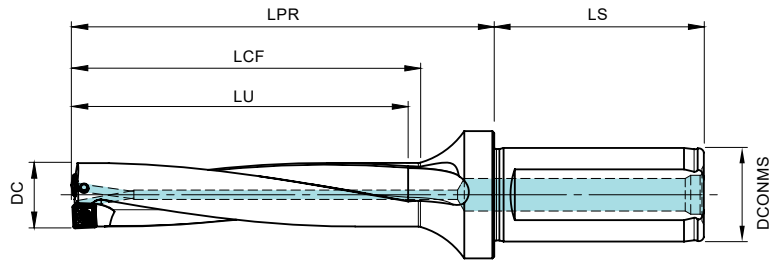
○ Available under request | Disponível sobre consulta | Disponible bajo consulta



| DC | DCONMS | BP / SP  | 5D      |                 |                |
|----|--------|----------|---------|-----------------|----------------|
|    |        |          | DC      | Drill tolerance | Hole tolerance |
| 20 | 50     | PT - 1/8 | 14-29,5 | 0/-0,15         | -0,05/+0,25    |
| 25 | 56     | PT - 1/8 | 30-42   | 0/-0,15         | -0,05/+0,30    |
| 32 | 60     | PT - 1/4 | 43-60   | 0/-0,15         | -0,05/+0,33    |

| Order code<br>Código | Reference<br>Referência<br>Referencia | Dimensions   Dimensões   Dimensiones (mm) |        |     |     |     | Inner<br>Insert | Outer<br>Insert | Insert Screw<br> | Torx key<br> | Stock |
|----------------------|---------------------------------------|---|--------|-----|-----|-----|-----------------|-----------------|--|--|-------|
|                      |                                       | DC  | DCONMS | LU  | LCF | LPR |                 |                 |  |  |       |
| 184332500            | XCS 14020-5D                          | 14,0                                      | 20     | 70  | 73  | 88  | XOKX 050204     | SOKX 050204     | P02004IP   | XT06IP   | ☺     |
| 184332600            | XCS 14520-5D                          | 14,5                                      | 20     | 73  | 76  | 91  | XOKX 050204     | SOKX 050204     | P02004IP   | XT06IP   | ☺     |
| 184332700            | XCS 15020-5D                          | 15,0                                      | 20     | 75  | 78  | 93  | XOKX 050204     | SOKX 050204     | P02004IP   | XT06IP   | ☺     |
| 184332800            | XCS 15520-5D                          | 15,5                                      | 20     | 78  | 81  | 96  | XOKX 050204     | SOKX 050204     | P02004IP   | XT06IP   | ☺     |
| 184332900            | XCS 16020-5D                          | 16,0                                      | 20     | 80  | 83  | 98  | XOKX 050204     | SOKX 050204     | P02004IP   | XT06IP   | ☺     |
| 184333000            | XCS 16525-5D                          | 16,5                                      | 25     | 83  | 86  | 106 | XOKX 060204     | SOKX 060205     | P02205IP   | XT06IP   | ☺     |
| 184333100            | XCS 17025-5D                          | 17,0                                      | 25     | 85  | 88  | 108 | XOKX 060204     | SOKX 060205     | P02205IP   | XT06IP   | ☺     |
| 184333200            | XCS 17525-5D                          | 17,5                                      | 25     | 88  | 91  | 111 | XOKX 060204     | SOKX 060205     | P02205IP   | XT06IP   | ☺     |
| 184333300            | XCS 18025-5D                          | 18,0                                      | 25     | 90  | 93  | 113 | XOKX 060204     | SOKX 060205     | P02205IP   | XT06IP   | ☺     |
| 184333400            | XCS 18525-5D                          | 18,5                                      | 25     | 93  | 96  | 116 | XOKX 060204     | SOKX 060205     | P02205IP   | XT06IP   | ☺     |
| 184333500            | XCS 19025-5D                          | 19,0                                      | 25     | 95  | 98  | 118 | XOKX 060204     | SOKX 060205     | P02205IP   | XT06IP   | ☺     |
| 184333600            | XCS 19525-5D                          | 19,5                                      | 25     | 98  | 101 | 121 | XOKX 060204     | SOKX 060205     | P02205IP   | XT06IP   | ☺     |
| 184333700            | XCS 20025-5D                          | 20,0                                      | 25     | 100 | 103 | 123 | XOKX 07T205     | SOKX 07T208     | P02507IP   | XT08IP   | ☺     |
| 184333800            | XCS 20525-5D                          | 20,5                                      | 25     | 103 | 106 | 126 | XOKX 07T205     | SOKX 07T208     | P02507IP   | XT08IP   | ☺     |
| 184333900            | XCS 21025-5D                          | 21,0                                      | 25     | 105 | 108 | 128 | XOKX 07T205     | SOKX 07T208     | P02507IP   | XT08IP   | ☺     |
| 184334000            | XCS 21525-5D                          | 21,5                                      | 25     | 108 | 111 | 131 | XOKX 07T205     | SOKX 07T208     | P02507IP   | XT08IP   | ☺     |
| 184334100            | XCS 22025-5D                          | 22,0                                      | 25     | 110 | 113 | 133 | XOKX 07T205     | SOKX 07T208     | P02507IP   | XT08IP   | ☺     |
| 184334200            | XCS 22525-5D                          | 22,5                                      | 25     | 113 | 116 | 136 | XOKX 07T205     | SOKX 07T208     | P02507IP   | XT08IP   | ☺     |
| 184334300            | XCS 23025-5D                          | 23,0                                      | 25     | 115 | 118 | 138 | XOKX 07T205     | SOKX 07T208     | P02507IP   | XT08IP   | ☺     |
| 184334400            | XCS 23525-5D                          | 23,5                                      | 25     | 118 | 121 | 141 | XOKX 07T205     | SOKX 07T208     | P02507IP   | XT08IP   | ☺     |



☺ Stock item | Produto de stock | Itens de stock

○ Available under request | Disponível sobre consulta | Disponible bajo consulta

Continue next page

# XCS 5D

Jet drills | Brocas jet | Brocas jet

| Order code<br>Código | Reference<br>Referência<br>Referencia | Dimensions   Dimensões   Dimensiones (mm) |        |     |     |     | Inner<br>Insert | Outer<br>Insert | Insert Screw<br> | Torx key<br> | Stock |
|----------------------|---------------------------------------|---|--------|-----|-----|-----|-----------------|-----------------|---|---|-------|
|                      |                                       | DC  | DCONMS | LU  | LCF | LPR |                 |                 |   |   |       |
| 184334500            | XCS 24032-5D                          | 24,0                                      | 32     | 120 | 123 | 148 | XOKX 090305     | SOKX 090308     | P030071P  | XT08IP  | 📦     |
| 184334600            | XCS 24532-5D                          | 24,5                                      | 32     | 123 | 126 | 151 | XOKX 090305     | SOKX 090308     | P030071P  | XT08IP  | 📦     |
| 184334700            | XCS 25032-5D                          | 25,0                                      | 32     | 125 | 128 | 153 | XOKX 090305     | SOKX 090308     | P030071P  | XT08IP  | 📦     |
| 184334800            | XCS 25532-5D                          | 25,5                                      | 32     | 128 | 131 | 156 | XOKX 090305     | SOKX 090308     | P030071P  | XT08IP  | 📦     |
| 184334900            | XCS 26032-5D                          | 26,0                                      | 32     | 130 | 133 | 158 | XOKX 090305     | SOKX 090308     | P030071P  | XT08IP  | 📦     |
| 184335000            | XCS 26532-5D                          | 26,5                                      | 32     | 133 | 136 | 161 | XOKX 090305     | SOKX 090308     | P030071P  | XT08IP  | 📦     |
| 184335100            | XCS 27032-5D                          | 27,0                                      | 32     | 135 | 138 | 163 | XOKX 090305     | SOKX 090308     | P030071P  | XT08IP  | 📦     |
| 184335200            | XCS 27532-5D                          | 27,5                                      | 32     | 138 | 141 | 176 | XOKX 090305     | SOKX 090308     | P030071P  | XT08IP  | 📦     |
| 184335300            | XCS 28032-5D                          | 28,0                                      | 32     | 140 | 143 | 168 | XOKX 090305     | SOKX 090308     | P030071P  | XT08IP  | 📦     |
| 184335400            | XCS 28532-5D                          | 28,5                                      | 32     | 143 | 146 | 171 | XOKX 090305     | SOKX 090308     | P030071P  | XT08IP  | 📦     |
| 184335500            | XCS 29032-5D                          | 29,0                                      | 32     | 145 | 148 | 173 | XOKX 090305     | SOKX 090308     | P030071P  | XT08IP  | 📦     |
| 184335600            | XCS 29532-5D                          | 29,5                                      | 32     | 148 | 151 | 176 | XOKX 090305     | SOKX 090308     | P030071P  | XT08IP  | 📦     |
| 184335700            | XCS 30032-5D                          | 30,0                                      | 32     | 152 | 155 | 180 | XOKX 11T306     | SOKX 11T308     | P035081P  | XT15IP-S35  | 📦     |
| 184335800            | XCS 31032-5D                          | 31,0                                      | 32     | 157 | 160 | 185 | XOKX 11T306     | SOKX 11T308     | P035081P  | XT15IP-S35  | 📦     |
| 184335900            | XCS 32032-5D                          | 32,0                                      | 32     | 162 | 165 | 190 | XOKX 11T306     | SOKX 11T308     | P035081P  | XT15IP-S35  | 📦     |
| 184336000            | XCS 33032-5D                          | 33,0                                      | 32     | 167 | 170 | 195 | XOKX 11T306     | SOKX 11T308     | P035081P  | XT15IP-S35  | 📦     |
| 184336100            | XCS 34032-5D                          | 34,0                                      | 32     | 172 | 175 | 200 | XOKX 11T306     | SOKX 11T308     | P035081P  | XT15IP-S35  | 📦     |
| 184336200            | XCS 35032-5D                          | 35,0                                      | 32     | 177 | 180 | 205 | XOKX 11T306     | SOKX 11T308     | P035081P  | XT15IP-S35  | 📦     |
| 184336300            | XCS 36040-5D                          | 36,0                                      | 40     | 182 | 185 | 215 | XOKX 130406     | SOKX 130410     | P040101P  | XT15IP-S35  | 📦     |
| 184336400            | XCS 37040-5D                          | 37,0                                      | 40     | 187 | 190 | 220 | XOKX 130406     | SOKX 130410     | P040101P  | XT15IP-S35  | 📦     |
| 184336500            | XCS 38040-5D                          | 38,0                                      | 40     | 192 | 195 | 225 | XOKX 130406     | SOKX 130410     | P040101P  | XT15IP-S35  | 📦     |
| 184336600            | XCS 39040-5D                          | 39,0                                      | 40     | 197 | 200 | 230 | XOKX 130406     | SOKX 130410     | P040101P  | XT15IP-S35  | 📦     |
| 184336700            | XCS 40040-5D                          | 40,0                                      | 40     | 202 | 205 | 235 | XOKX 130406     | SOKX 130410     | P040101P  | XT15IP-S35  | 📦     |
| 184336800            | XCS 41040-5D                          | 41,0                                      | 40     | 207 | 210 | 240 | XOKX 130406     | SOKX 130410     | P040101P  | XT15IP-S35  | 📦     |
| 184336900            | XCS 42040-5D                          | 42,0                                      | 40     | 212 | 215 | 245 | XOKX 130406     | SOKX 130410     | P040101P  | XT15IP-S35  | 📦     |
| 184337000            | XCS 43040-5D                          | 43,0                                      | 40     | 217 | 220 | 250 | XOKX 150508     | SOKX 150510     | P050131P  | XT20IP-S40  | 📦     |
| 184337100            | XCS 44040-5D                          | 44,0                                      | 40     | 222 | 225 | 255 | XOKX 150508     | SOKX 150510     | P050131P  | XT20IP-S40  | 📦     |
| 184337200            | XCS 45040-5D                          | 45,0                                      | 40     | 227 | 230 | 260 | XOKX 150508     | SOKX 150510     | P050131P  | XT20IP-S40  | 📦     |
| 184337300            | XCS 46040-5D                          | 46,0                                      | 40     | 232 | 235 | 265 | XOKX 150508     | SOKX 150510     | P050131P  | XT20IP-S40  | 📦     |
| 184337400            | XCS 47040-5D                          | 47,0                                      | 40     | 237 | 240 | 270 | XOKX 150508     | SOKX 150510     | P050131P  | XT20IP-S40  | 📦     |
| 184337500            | XCS 48040-5D                          | 48,0                                      | 40     | 242 | 245 | 275 | XOKX 150508     | SOKX 150510     | P050131P  | XT20IP-S40  | 📦     |
| 184337600            | XCS 49040-5D                          | 49,0                                      | 40     | 247 | 250 | 280 | XOKX 150508     | SOKX 150510     | P050131P  | XT20IP-S40  | 📦     |
| 184337700            | XCS 50040-5D                          | 50,0                                      | 40     | 252 | 255 | 285 | XOKX 150508     | SOKX 150510     | P050131P  | XT20IP-S40  | 📦     |
| 184343200            | XCS 51040-5D                          | 51,0                                      | 40     | 257 | 260 | 290 | XOKX 180508     | SOKX 180510     | P050131P  | XT20IP-S40  | 📦     |
| 184343300            | XCS 52040-5D                          | 52,0                                      | 40     | 262 | 265 | 295 | XOKX 180508     | SOKX 180510     | P050131P  | XT20IP-S40  | 📦     |
| 184343400            | XCS 53040-5D                          | 53,0                                      | 40     | 267 | 270 | 300 | XOKX 180508     | SOKX 180510     | P050131P  | XT20IP-S40  | 📦     |
| 184343500            | XCS 54040-5D                          | 54,0                                      | 40     | 272 | 275 | 305 | XOKX 180508     | SOKX 180510     | P050131P  | XT20IP-S40  | 📦     |
| 184343600            | XCS 55040-5D                          | 55,0                                      | 40     | 277 | 280 | 310 | XOKX 180508     | SOKX 180510     | P050131P  | XT20IP-S40  | 📦     |
| 184343700            | XCS 56040-5D                          | 56,0                                      | 40     | 282 | 285 | 315 | XOKX 180508     | SOKX 180510     | P050131P  | XT20IP-S40  | 📦     |
| 184343800            | XCS 57040-5D                          | 57,0                                      | 40     | 287 | 290 | 320 | XOKX 180508     | SOKX 180510     | P050131P  | XT20IP-S40  | 📦     |
| 184343900            | XCS 58040-5D                          | 58,0                                      | 40     | 292 | 295 | 325 | XOKX 180508     | SOKX 180510     | P050131P  | XT20IP-S40  | 📦     |
| 184344000            | XCS 59040-5D                          | 59,0                                      | 40     | 297 | 300 | 330 | XOKX 180508     | SOKX 180510     | P050131P  | XT20IP-S40  | 📦     |
| 184344100            | XCS 60040-5D                          | 60,0                                      | 40     | 302 | 305 | 335 | XOKX 180508     | SOKX 180510     | P050131P  | XT20IP-S40  | 📦     |

📦 Stock item | Produto de stock | Itens de stock

○ Available under request | Disponível sobre consulta | Disponible bajo consulta

**SOKX OUTER INSERT**



SOKX-MP



SOKX-MS

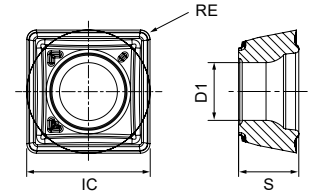

SOKX-MP | MS

| Jet Drills | Geometry code | ISO Reference  | P   |    |     | M   |    | K   |    |     | S   |    | Dimensions   Dimensões   Dimensiones (mm) |      |      |      |
|------------|---------------|----------------|-----|----|-----|-----|----|-----|----|-----|-----|----|---|------|------|------|
|            |               |                | PVD |    | CVD | PVD |    | PVD |    | CVD | PVD |    | IC  | S    | D1   | RE   |
|            |               |                | T1  | P4 | 2C  | Y3  | X9 | T1  | P4 | 2C  | Y3  | X9 |   |      |      |      |
|            | 1142113       | SOKX 050204-MP | ⊗   |    | ⊗   |     |    | ⊗   |    | ⊗   |     |    | 5,10                                      | 2,50 | 2,40 | 0,40 |
|            | 1142115       | SOKX 060205-MP | ⊗   |    | ⊗   |     |    | ⊗   |    | ⊗   |     |    | 6,20                                      | 2,60 | 2,60 | 0,50 |
|            | 1142117       | SOKX 07T208-MP | ⊗   |    | ⊗   |     |    | ⊗   |    | ⊗   |     |    | 7,50                                      | 2,90 | 2,90 | 0,80 |
|            | 1142119       | SOKX 090308-MP | ⊗   |    | ⊗   |     |    | ⊗   |    | ⊗   |     |    | 9,20                                      | 3,50 | 3,50 | 0,80 |
|            | 1142121       | SOKX 11T308-MP | ⊗   |    | ⊗   |     |    | ⊗   |    | ⊗   |     |    | 11,00                                     | 4,20 | 4,10 | 0,80 |
|            | 1142123       | SOKX 130410-MP | ⊗   |    | ⊗   |     |    | ⊗   |    | ⊗   |     |    | 13,00                                     | 4,73 | 4,60 | 1,00 |
|            | 1142125       | SOKX 150510-MP | ⊗   |    | ⊗   |     |    | ⊗   |    | ⊗   |     |    | 15,20                                     | 5,30 | 5,60 | 1,00 |
|            | 1142160       | SOKX 180510-MP | ⊗   |    | ⊗   |     |    | ⊗   |    | ⊗   |     |    | 18,20                                     | 5,30 | 5,60 | 1,00 |
|            | 1142127       | SOKX 050204-MS |     |    |     | ⊗   |    |     |    |     | ⊗   |    | 5,10                                      | 2,50 | 2,40 | 0,40 |
|            | 1142129       | SOKX 060205-MS |     |    |     | ⊗   |    |     |    |     | ⊗   |    | 6,20                                      | 2,60 | 2,60 | 0,50 |
|            | 1142131       | SOKX 07T208-MS |     |    |     | ⊗   |    |     |    |     | ⊗   |    | 7,50                                      | 2,90 | 2,90 | 0,80 |
|            | 1142133       | SOKX 090308-MS |     |    |     | ⊗   |    |     |    |     | ⊗   |    | 9,20                                      | 3,50 | 3,50 | 0,80 |
|            | 1142135       | SOKX 11T308-MS |     |    |     | ⊗   |    |     |    |     | ⊗   |    | 11,00                                     | 4,20 | 4,10 | 0,80 |
|            | 1142137       | SOKX 130410-MS |     |    |     | ⊗   |    |     |    |     | ⊗   |    | 13,00                                     | 4,73 | 4,60 | 1,00 |
|            | 1142139       | SOKX 150510-MS |     |    |     | ⊗   |    |     |    |     | ⊗   |    | 15,20                                     | 5,30 | 5,60 | 1,00 |
|            | 1142162       | SOKX 180510-MS |     |    |     | ⊗   |    |     |    |     | ⊗   |    | 18,20                                     | 5,30 | 5,60 | 1,00 |

⊗ Stock item | Produto de stock | Itens de stock    ○ Available under request | Disponível sob consulta | Disponible bajo consulta

Insert order code = <sup>(1)</sup> Geometry code + <sup>(2)</sup> Grade code

# INSERTS

Pastilhas | Plaquetas

## XOKX INNER INSERT



XOKX-MP



XOKX-MS

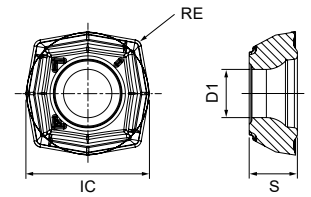

XOKX-MP | MS

| (1)<br>Geometry code | ISO Reference  | P   |    | M   |    | K   |    | S   |    | Dimensions   Dimensões   Dimensiones (mm) |      |      |      |
|----------------------|----------------|-----|----|-----|----|-----|----|-----|----|---|------|------|------|
|                      |                | PVD |    | PVD |    | PVD |    | PVD |    |   |      |      |      |
|                      |                | T1  | P4 | Y3  | X9 | T1  | P4 | Y3  | X9 | IC  | S    | D1   | RE   |
| 1142112              | XOKX 050204-MP | ⊗   | ⊗  |     |    |     | ⊗  |     |    | 5,40                                      | 2,50 | 2,40 | 0,40 |
| 1142114              | XOKX 060204-MP |     | ⊗  |     |    |     | ⊗  |     |    | 6,56                                      | 2,50 | 2,60 | 0,40 |
| 1142116              | XOKX 07T205-MP |     | ⊗  |     |    |     | ⊗  |     |    | 7,80                                      | 2,90 | 2,90 | 0,50 |
| 1142118              | XOKX 090305-MP |     | ⊗  |     |    |     | ⊗  |     |    | 9,60                                      | 3,50 | 3,50 | 0,50 |
| 1142120              | XOKX 11T306-MP |     | ⊗  |     |    |     | ⊗  |     |    | 11,38                                     | 4,15 | 4,10 | 0,60 |
| 1142122              | XOKX 130406-MP |     | ⊗  |     |    |     | ⊗  |     |    | 13,60                                     | 4,68 | 4,60 | 0,60 |
| 1142124              | XOKX 150508-MP |     | ⊗  |     |    |     | ⊗  |     |    | 15,90                                     | 5,30 | 5,60 | 0,80 |
| 1142159              | XOKX 180508-MP |     | ⊗  |     |    |     | ⊗  |     |    | 18,20                                     | 5,30 | 5,60 | 0,80 |
| 1142126              | XOKX 050204-MS |     |    |     | ⊗  |     |    |     | ⊗  | 5,40                                      | 2,50 | 2,40 | 0,40 |
| 1142128              | XOKX 060204-MS |     |    |     | ⊗  |     |    |     | ⊗  | 6,60                                      | 2,60 | 2,60 | 0,40 |
| 1142130              | XOKX 07T205-MS |     |    |     | ⊗  |     |    |     | ⊗  | 7,80                                      | 2,90 | 2,90 | 0,50 |
| 1142132              | XOKX 090305-MS |     |    |     | ⊗  |     |    |     | ⊗  | 9,60                                      | 3,50 | 3,50 | 0,50 |
| 1142134              | XOKX 11T306-MS |     |    |     | ⊗  |     |    |     | ⊗  | 11,38                                     | 4,20 | 4,10 | 0,60 |
| 1142136              | XOKX 130406-MS |     |    |     | ⊗  |     |    |     | ⊗  | 13,60                                     | 4,68 | 4,60 | 0,60 |
| 1142138              | XOKX 150508-MS |     |    |     | ⊗  |     |    |     | ⊗  | 15,90                                     | 5,30 | 5,60 | 0,80 |
| 1142161              | XOKX 180508-MS |     |    |     | ⊗  |     |    |     | ⊗  | 18,20                                     | 5,30 | 5,60 | 0,80 |

⊗ Stock item | Produto de stock | Itens de stock    ○ Available under request | Disponível sob consulta | Disponible bajo consulta

Insert order code = <sup>(1)</sup> Geometry code + <sup>(2)</sup> Grade code

| ISO | Material Group              | Vc (m/min) | fn (mm/rev) |             |           |           |           |
|-----|-----------------------------|------------|-------------|-------------|-----------|-----------|-----------|
|     |                             |            | Ø14-Ø16     | Ø16,5-Ø23,5 | Ø24-Ø29,5 | Ø30-Ø42   | Ø43-Ø60   |
| P   | Unalloyed steel (-0,25%)    | 160-250    | 0,04-0,08   | 0,04-0,08   | 0,04-0,10 | 0,05-0,12 | 0,05-0,14 |
|     | Low-alloy steel             | 120-220    | 0,04-0,10   | 0,04-0,12   | 0,05-0,15 | 0,06-0,18 | 0,06-0,20 |
|     | High-alloy steel            | 120-180    | 0,04-0,12   | 0,05-0,12   | 0,07-0,16 | 0,08-0,18 | 0,08-0,20 |
| M   | Stainless steel             | 130-220    | 0,04-0,10   | 0,04-0,12   | 0,05-0,14 | 0,06-0,16 | 0,06-0,18 |
| K   | Grey cast iron              | 150-250    | 0,04-0,10   | 0,05-0,14   | 0,05-0,17 | 0,08-0,20 | 0,08-0,25 |
|     | Cast iron with nodular cast | 100-200    | 0,04-0,12   | 0,04-0,12   | 0,05-0,14 | 0,06-0,15 | 0,06-0,18 |
| S   | Super-alloys and titanium   | 30-90      | 0,04-0,08   | 0,04-0,08   | 0,04-0,11 | 0,07-0,12 | 0,08-0,15 |

**NOTES**

When working on irregular surfaces, please reduce the feed rate by 30%-50%. To ensure the best performance, make sure to use the proper oil pressure (over 5kg/cm2) and follow the cutting data parameters.

**Power requirements**

**Cutting oil quantity**

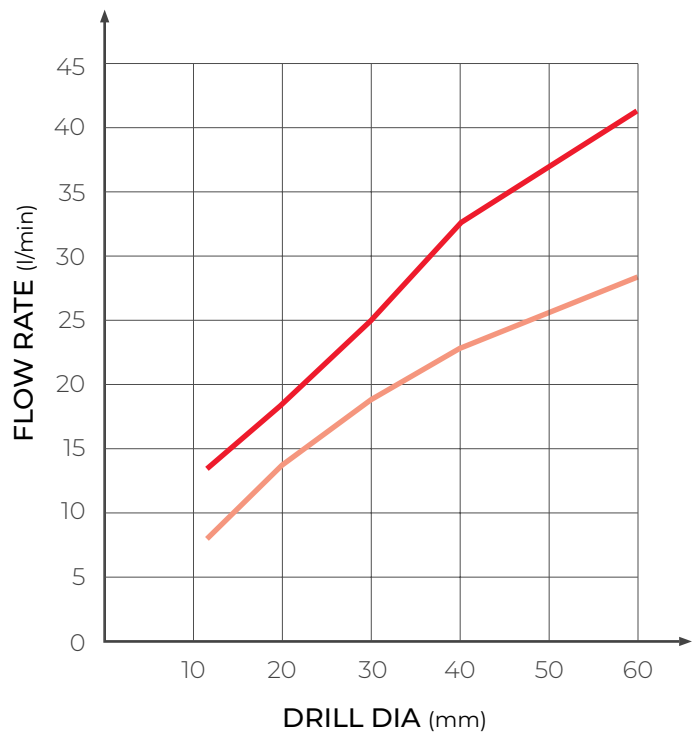
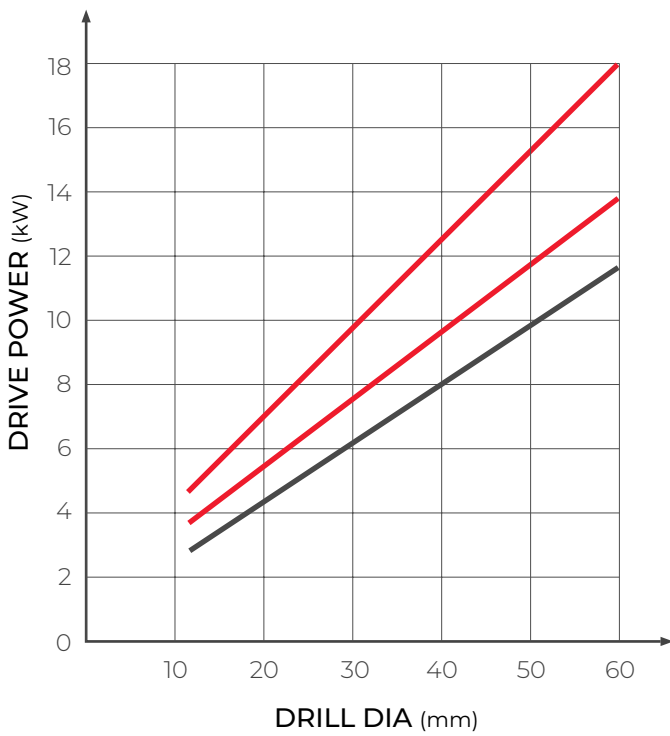

- F = 0,13 mm/r
- F = 0,10 mm/r
- F = 0,07 mm/r

- Recommended cutting oil quantity
- Min. cutting oil quantity

**NOTES**

Minimum pressure coolant: 5bar

## GRADE SELECTION INNER INSERT

### PVD

Due to the reduced cutting speed in the central area of the drill, a tougher grade is recommended for the inner insert.

**PHP930**

P20-P40

K10-K30

**PHH930**

M20-M40

S20-S30

## GRADE SELECTION OUTER INSERT

### PVD

First choice for stable machining and improved surface finish. Recommended for outer edge if chattering occurs.

**PHP920**

P10-P35

K10-K30

**PHH920**

M10-M25

S15-S30

### CVD

First choice for high speeds and high efficiency machining, abrasion resistance and longer tool life.

**PHS130**

P10-P35

K20-K40

| Drill diameter (Ø) | Diameter range (Ø) | Drill diameter (Ø) | Diameter range (Ø) | Drill diameter (Ø) | Diameter range (Ø) |
|--------------------|--------------------|--------------------|--------------------|--------------------|--------------------|
| Ø14,0              | 13,6~14,5          | Ø28,0              | 27,4~28,6          | Ø42,0              | 41,3~42,7          |
| Ø14,5              | 14,1~15,0          | Ø28,5              | 27,9~29,1          | Ø42,5              | 41,8~43,2          |
| Ø15,0              | 14,6~15,5          | Ø29,0              | 28,4~29,6          | Ø43,0              | 42,2~43,7          |
| Ø15,5              | 15,1~16,0          | Ø29,5              | 28,9~30,1          | Ø43,5              | 42,7~44,2          |
| Ø16,0              | 15,6~16,5          | Ø30,0              | 29,3~30,7          | Ø44,0              | 43,2~44,7          |
| Ø16,5              | 16,0~17,0          | Ø30,5              | 29,8~31,2          | Ø44,5              | 43,7~45,2          |
| Ø17,0              | 16,5~17,5          | Ø31,0              | 30,3~31,7          | Ø45,0              | 44,2~45,7          |
| Ø17,5              | 17,0~18,0          | Ø31,5              | 30,8~32,2          | Ø45,5              | 44,7~46,2          |
| Ø18,0              | 17,5~18,5          | Ø32,0              | 31,3~32,7          | Ø46,0              | 45,2~46,7          |
| Ø18,5              | 18,0~19,0          | Ø32,5              | 31,8~33,2          | Ø46,5              | 45,7~47,2          |
| Ø19,0              | 18,5~19,5          | Ø33,0              | 32,3~33,7          | Ø47,0              | 46,2~47,7          |
| Ø19,5              | 19,0~20,0          | Ø33,5              | 32,8~34,2          | Ø47,5              | 46,7~48,2          |
| Ø20,0              | 19,4~20,6          | Ø34,0              | 33,3~34,7          | Ø48,0              | 47,2~48,7          |
| Ø20,5              | 19,9~21,1          | Ø34,5              | 33,8~35,2          | Ø48,5              | 47,7~49,2          |
| Ø21,0              | 20,4~21,6          | Ø35,0              | 34,3~35,7          | Ø49,0              | 48,2~49,7          |
| Ø21,5              | 20,9~22,1          | Ø35,5              | 34,8~36,2          | Ø49,5              | 48,7~50,2          |
| Ø22,0              | 21,4~22,6          | Ø36,0              | 35,3~36,7          | Ø50,0              | 49,2~50,7          |
| Ø22,5              | 21,9~23,1          | Ø36,5              | 35,8~37,2          | Ø51,0              | 50,2~51,7          |
| Ø23,0              | 22,4~23,6          | Ø37,0              | 36,3~37,7          | Ø52,0              | 51,2~52,7          |
| Ø23,5              | 22,9~24,1          | Ø37,5              | 36,8~38,2          | Ø53,0              | 52,2~53,7          |
| Ø24,0              | 23,4~24,6          | Ø38,0              | 37,3~38,7          | Ø54,0              | 53,2~54,7          |
| Ø24,5              | 23,9~25,1          | Ø38,5              | 37,8~39,2          | Ø55,0              | 54,2~55,7          |
| Ø25,0              | 24,4~25,6          | Ø39,0              | 38,3~39,7          | Ø56,0              | 55,2~56,7          |
| Ø25,5              | 24,9~26,1          | Ø39,5              | 38,8~40,2          | Ø57,0              | 56,2~57,7          |
| Ø26,0              | 25,4~26,6          | Ø40,0              | 39,3~40,7          | Ø58,0              | 57,2~58,7          |
| Ø26,5              | 25,9~27,1          | Ø40,5              | 39,8~41,2          | Ø59,0              | 58,2~59,7          |
| Ø27,0              | 26,4~27,6          | Ø41,0              | 40,3~41,7          | Ø60,0              | 59,2~60,7          |
| Ø27,5              | 26,9~28,1          | Ø41,5              | 40,8~42,2          |                    |                    |

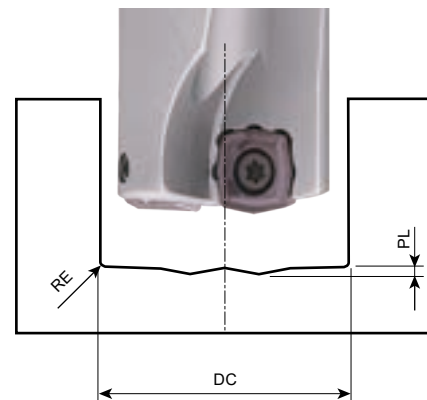

| Drill diameter (mm) | Outer insert | Inner insert | PL  | RE  |
|---------------------|--------------|--------------|-----|-----|
| Ø14,0-16,0          | SOKX 050204  | XOKX 050204  | 0,4 | 0,4 |
| Ø16,5-19,5          | SOKX 060205  | XOKX 060205  | 0,5 | 0,5 |
| Ø20,0-24,0          | SOKX 07T208  | XOKX 07T208  | 0,5 | 0,8 |
| Ø24,5-30,0          | SOKX 090308  | XOKX 090308  | 0,7 | 0,8 |
| Ø31,0-35,0          | SOKX 11T308  | XOKX 11T308  | 0,8 | 0,8 |
| Ø36,0-42,0          | SOKX 130410  | XOKX 130410  | 1,0 | 1,0 |
| Ø43,0-50,0          | SOKX 150510  | XOKX 150508  | 1,1 | 1,0 |
| Ø51,0-60,0          | SOKX 180510  | XOKX 180508  | 1,2 | 1,0 |

## RULES & TIPS

Regras e dicas | Reglas y consejos

| Workpiece  | Machining  |
|--|--|
|  <p><b>Irregular surface</b></p>        | <ul style="list-style-type: none"> <li>· Decrease the feed by 25%;</li> <li>· Potential chipping and fracture;</li> </ul>  |
|  <p><b>Inclined surface</b></p>         | <ul style="list-style-type: none"> <li>· Decrease the feed by 50%.</li> </ul>  |
|  <p><b>Convex / Concave surface</b></p> | <ul style="list-style-type: none"> <li>· Decrease the feed by 50% until both inserts are engaged;</li> <li>· Potential initial contact with the central insert identified (convex surface);</li> </ul> |
|  <p><b>Boring</b></p>                   | <ul style="list-style-type: none"> <li>· Decrease the feed by 50%.</li> </ul>  |
|  <p><b>Crossing holes</b></p>           | <ul style="list-style-type: none"> <li>· Decrease the feed by 50% in the overlapped section.</li> </ul>  |
|  <p><b>Chain holemaking</b></p>         | <ul style="list-style-type: none"> <li>· Decrease the feed by 50%.</li> </ul>  |
|  <p><b>Stack holemaking</b></p>         | <ul style="list-style-type: none"> <li>· Decrease the feed by 25%;</li> <li>· Potential chipping and fracture;</li> </ul>  |

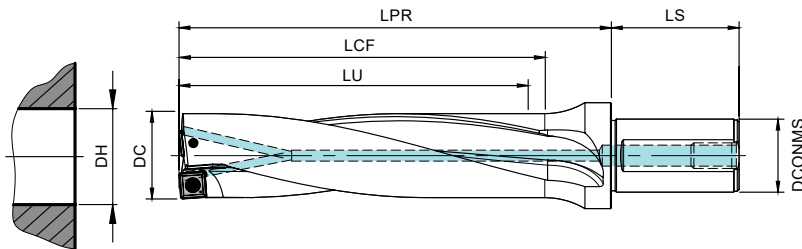

| DC | DCONMS | BP / SP  | ØDH tolerance (mm) |               |
|----|--------|----------|--------------------|---------------|
|    |        |          | DC                 | 3D            |
| 20 | 50     | PT - 1/8 | 13,0 - 21,5        | -0,10 / +0,15 |
| 25 | 56     | PT - 1/8 | 22,0 - 50,0        | -0,12 / +0,20 |
| 32 | 60     | PT - 1/4 |                    |               |
| 40 | 70     | PT - 1/4 |                    |               |

| Order code<br>Código | Reference<br>Referência<br>Referencia | Dimensions   Dimensões   Dimensiones (mm) |        |    |     |     | Insert      | Insert Screw | Torx key | Stock |
|----------------------|---------------------------------------|---|--------|----|-----|-----|-------------|--------------|----------|-------|
|                      |                                       | DC  | DCONMS | LU | LCF | LPR |             |              |          |       |
| 184041400            | SCS 13020-3D                          | 13,0                                      | 20     | 39 | 42  | 62  | SPKX 050204 | P0200500     | XT06     | ☺     |
| 184041500            | SCS 13520-3D                          | 13,5                                      | 20     | 41 | 44  | 64  | SPKX 050204 | P0200500     | XT06     | ☺     |
| 184041600            | SCS 14020-3D                          | 14,0                                      | 20     | 42 | 45  | 65  | SPKX 050204 | P0200500     | XT06     | ☺     |
| 184041700            | SCS 14520-3D                          | 14,5                                      | 20     | 44 | 47  | 67  | SPKX 050204 | P0200500     | XT06     | ☺     |
| 184041800            | SCS 15020-3D                          | 15,0                                      | 20     | 45 | 48  | 68  | SPKX 050204 | P0200500     | XT06     | ☺     |
| 184041900            | SCS 15525-3D                          | 15,5                                      | 25     | 47 | 50  | 75  | SP.X 060204 | P0220500     | XT07     | ☺     |
| 184042000            | SCS 16025-3D                          | 16,0                                      | 25     | 48 | 51  | 76  | SP.X 060204 | P0220500     | XT07     | ☺     |
| 184042100            | SCS 16525-3D                          | 16,5                                      | 25     | 50 | 53  | 78  | SP.X 060204 | P0220500     | XT07     | ☺     |
| 184042200            | SCS 17025-3D                          | 17,0                                      | 25     | 51 | 54  | 79  | SP.X 060204 | P0220500     | XT07     | ☺     |
| 184042300            | SCS 17525-3D                          | 17,5                                      | 25     | 53 | 56  | 81  | SP.X 060204 | P0220500     | XT07     | ☺     |
| 184042400            | SCS 18025-3D                          | 18,0                                      | 25     | 54 | 57  | 82  | SP.X 060204 | P0220500     | XT07     | ☺     |
| 184042500            | SCS 18525-3D                          | 18,5                                      | 25     | 56 | 59  | 84  | SP.X 060204 | P0220500     | XT07     | ☺     |
| 184042600            | SCS 19025-3D                          | 19,0                                      | 25     | 57 | 60  | 85  | SP.X 060204 | P0220500     | XT07     | ☺     |
| 184042700            | SCS 19525-3D                          | 19,5                                      | 25     | 59 | 62  | 87  | SP.X 060204 | P0220500     | XT07     | ☺     |
| 184042800            | SCS 20025-3D                          | 20,0                                      | 25     | 60 | 63  | 88  | SP.X 060204 | P0220500     | XT07     | ☺     |
| 184042900            | SCS 20525-3D                          | 20,5                                      | 25     | 62 | 65  | 90  | SP.X 060204 | P0220500     | XT07     | ☺     |
| 184043000            | SCS 21025-3D                          | 21,0                                      | 25     | 63 | 66  | 91  | SP.X 060204 | P0220500     | XT07     | ☺     |
| 184043100            | SCS 21525-3D                          | 21,5                                      | 25     | 65 | 68  | 93  | SP.X 060204 | P0220500     | XT07     | ☺     |
| 184043200            | SCS 22032-3D                          | 22,0                                      | 32     | 66 | 69  | 99  | SPKX 07T308 | P0250704     | XT08     | ☺     |
| 184043300            | SCS 22532-3D                          | 22,5                                      | 32     | 68 | 71  | 101 | SPKX 07T308 | P0250704     | XT08     | ☺     |
| 184043400            | SCS 23032-3D                          | 23,0                                      | 32     | 69 | 72  | 102 | SPKX 07T308 | P0250704     | XT08     | ☺     |
| 184043500            | SCS 23532-3D                          | 23,5                                      | 32     | 71 | 74  | 104 | SPKX 07T308 | P0250704     | XT08     | ☺     |
| 184043600            | SCS 24032-3D                          | 24,0                                      | 32     | 72 | 75  | 105 | SPKX 07T308 | P0250704     | XT08     | ☺     |
| 184043700            | SCS 24532-3D                          | 24,5                                      | 32     | 74 | 77  | 107 | SPKX 07T308 | P0250704     | XT08     | ☺     |
| 184043800            | SCS 25032-3D                          | 25,0                                      | 32     | 75 | 78  | 108 | SPKX 07T308 | P0250704     | XT08     | ☺     |
| 184043900            | SCS 25532-3D                          | 25,5                                      | 32     | 77 | 80  | 110 | SPKX 07T308 | P0250704     | XT08     | ☺     |
| 184044000            | SCS 26032-3D                          | 26,0                                      | 32     | 78 | 81  | 111 | SPKX 07T308 | P0250704     | XT08     | ☺     |



☺ Stock item | Produto de stock | Itens de stock

○ Available under request | Disponível sobre consulta | Disponible bajo consulta

Continue next page

# SCS 3D

Jet drills | Brocas jet | Brocas jet







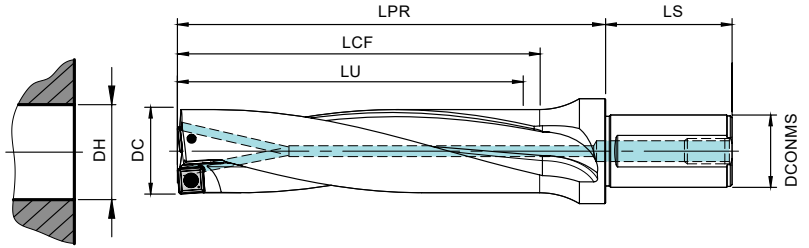























| Order code<br>Código | Reference<br>Referência<br>Referencia | Dimensions   Dimensões   Dimensiones (mm) |        |     |     |     | Insert      | Insert Screw<br> | Torx key<br> | Stock |
|----------------------|---------------------------------------|---|--------|-----|-----|-----|-------------|---|---|-------|
|                      |                                       | DC  | DCONMS | LU  | LCF | LPR |             |   |   |       |
| 184044100            | SCS 26532-3D                          | 26,5                                      | 32     | 80  | 83  | 113 | SPKX 07T308 | P0250704  | XT08  | 📦     |
| 184044200            | SCS 27032-3D                          | 27,0                                      | 32     | 81  | 84  | 114 | SPKX 07T308 | P0250704  | XT08  | 📦     |
| 184044400            | SCS 27532-3D                          | 27,5                                      | 32     | 83  | 86  | 116 | SPKX 07T308 | P0250704  | XT08  | 📦     |
| 184044500            | SCS 28032-3D                          | 28,0                                      | 32     | 84  | 87  | 117 | SPKX 090408 | P0350903  | XT15  | 📦     |
| 184044600            | SCS 28532-3D                          | 28,5                                      | 32     | 86  | 89  | 119 | SPKX 090408 | P0350903  | XT15  | 📦     |
| 184044700            | SCS 29032-3D                          | 29,0                                      | 32     | 87  | 90  | 120 | SPKX 090408 | P0350903  | XT15  | 📦     |
| 184044800            | SCS 29532-3D                          | 29,5                                      | 32     | 89  | 93  | 123 | SPKX 090408 | P0350903  | XT15  | 📦     |
| 184044900            | SCS 30032-3D                          | 30,0                                      | 32     | 90  | 95  | 125 | SPKX 090408 | P0350903  | XT15  | 📦     |
| 184045000            | SCS 31032-3D                          | 31,0                                      | 32     | 93  | 98  | 128 | SPKX 090408 | P0350903  | XT15  | 📦     |
| 184045100            | SCS 32032-3D                          | 32,0                                      | 32     | 96  | 101 | 131 | SPKX 090408 | P0350903  | XT15  | 📦     |
| 184045200            | SCS 33032-3D                          | 33,0                                      | 32     | 99  | 104 | 134 | SPKX 090408 | P0350903  | XT15  | 📦     |
| 184045300            | SCS 34040-3D                          | 34,0                                      | 40     | 102 | 107 | 142 | SPKX 110408 | P0401200  | XT15  | 📦     |
| 184045400            | SCS 35040-3D                          | 35,0                                      | 40     | 105 | 110 | 145 | SPKX 110408 | P0401200  | XT15  | 📦     |
| 184045500            | SCS 36040-3D                          | 36,0                                      | 40     | 108 | 113 | 148 | SPKX 110408 | P0401200  | XT15  | 📦     |
| 184045600            | SCS 37040-3D                          | 37,0                                      | 40     | 111 | 116 | 151 | SPKX 110408 | P0401200  | XT15  | 📦     |
| 184045700            | SCS 38040-3D                          | 38,0                                      | 40     | 114 | 119 | 154 | SPKX 110408 | P0401200  | XT15  | 📦     |
| 184045800            | SCS 39040-3D                          | 39,0                                      | 40     | 117 | 122 | 157 | SPKX 110408 | P0401200  | XT15  | 📦     |
| 184045900            | SCS 40040-3D                          | 40,0                                      | 40     | 120 | 125 | 160 | SPKX 110408 | P0401200  | XT15  | 📦     |
| 184046000            | SCS 41040-3D                          | 41,0                                      | 40     | 123 | 128 | 163 | SPKX 110408 | P0401200  | XT15  | 📦     |
| 184046100            | SCS 42040-3D                          | 42,0                                      | 40     | 126 | 131 | 166 | SPKX 140512 | P0501300  | XT20  | 📦     |
| 184046200            | SCS 43040-3D                          | 43,0                                      | 40     | 129 | 134 | 169 | SPKX 140512 | P0501300  | XT20  | 📦     |
| 184046300            | SCS 44040-3D                          | 44,0                                      | 40     | 132 | 137 | 172 | SPKX 140512 | P0501300  | XT20  | 📦     |
| 184046400            | SCS 45040-3D                          | 45,0                                      | 40     | 135 | 140 | 175 | SPKX 140512 | P0501300  | XT20  | 📦     |
| 184046500            | SCS 46040-3D                          | 46,0                                      | 40     | 138 | 143 | 178 | SPKX 140512 | P0501300  | XT20  | 📦     |
| 184046600            | SCS 47040-3D                          | 47,0                                      | 40     | 141 | 146 | 181 | SPKX 140512 | P0501300  | XT20  | 📦     |
| 184046700            | SCS 48040-3D                          | 48,0                                      | 40     | 144 | 149 | 184 | SPKX 140512 | P0501300  | XT20  | 📦     |
| 184046800            | SCS 49040-3D                          | 49,0                                      | 40     | 147 | 152 | 187 | SPKX 140512 | P0501300  | XT20  | 📦     |
| 184046900            | SCS 50040-3D                          | 50,0                                      | 40     | 150 | 155 | 190 | SPKX 140512 | P0501300  | XT20  | 📦     |

📦 Stock item | Produto de stock | Itens de stock

○ Available under request | Disponível sobre consulta | Disponible bajo consulta



| DC | DCONMS | BP / SP  | ØDH tolerance (mm) |               |
|----|--------|----------|--------------------|---------------|
|    |        |          | DC                 | 3D            |
| 20 | 50     | PT - 1/8 | 13,0 - 21,5        | -0,15 / +0,20 |
| 25 | 56     | PT - 1/8 | 22,0 - 50,0        | -0,15 / +0,25 |
| 32 | 60     | PT - 1/4 |                    |               |
| 40 | 70     | PT - 1/4 |                    |               |

| Order code<br>Código | Reference<br>Referência<br>Referencia | Dimensions   Dimensões   Dimensiones (mm) |        |     |     |     | Insert       | Insert Screw<br> | Torx key<br> | Stock<br> |
|----------------------|---------------------------------------|---|--------|-----|-----|-----|--------------|--|--|---|
|                      |                                       | DC  | DCONMS | LU  | LCF | LPR |              |  |  |   |
| 184047100            | SCS 13020-4D                          | 13,0                                      | 20     | 52  | 55  | 75  | SPKX 050204  | P0200500   | XT06   |          |
| 184047200            | SCS 13520-4D                          | 13,5                                      | 20     | 54  | 57  | 77  | SPKX 050204  | P0200500   | XT06   |          |
| 184047300            | SCS 14020-4D                          | 14,0                                      | 20     | 56  | 59  | 79  | SPKX 050204  | P0200500   | XT06   |          |
| 184047400            | SCS 14520-4D                          | 14,5                                      | 20     | 58  | 61  | 81  | SPKX 050204  | P0200500   | XT06   |          |
| 184047500            | SCS 15020-4D                          | 15,0                                      | 20     | 60  | 63  | 83  | SPKX 050204  | P0200500   | XT06   |          |
| 184047600            | SCS 15525-4D                          | 15,5                                      | 25     | 62  | 65  | 90  | SP..X 060204 | P0220500   | XT07   |          |
| 184047700            | SCS 16025-4D                          | 16,0                                      | 25     | 64  | 67  | 92  | SP..X 060204 | P0220500   | XT07   |          |
| 184047800            | SCS 16525-4D                          | 16,5                                      | 25     | 66  | 69  | 94  | SP..X 060204 | P0220500   | XT07   |          |
| 184047900            | SCS 17025-4D                          | 17,0                                      | 25     | 68  | 71  | 96  | SP..X 060204 | P0220500   | XT07   |          |
| 184048000            | SCS 17525-4D                          | 17,5                                      | 25     | 70  | 73  | 98  | SP..X 060204 | P0220500   | XT07   |          |
| 184048100            | SCS 18025-4D                          | 18,0                                      | 25     | 72  | 75  | 100 | SP..X 060204 | P0220500   | XT07   |          |
| 184048200            | SCS 18525-4D                          | 18,5                                      | 25     | 74  | 77  | 102 | SP..X 060204 | P0220500   | XT07   |          |
| 184048300            | SCS 19025-4D                          | 19,0                                      | 25     | 76  | 79  | 104 | SP..X 060204 | P0220500   | XT07   |          |
| 184048400            | SCS 19525-4D                          | 19,5                                      | 25     | 78  | 81  | 106 | SP..X 060204 | P0220500   | XT07   |          |
| 184048500            | SCS 20025-4D                          | 20,0                                      | 25     | 80  | 83  | 108 | SP..X 060204 | P0220500   | XT07   |          |
| 184048600            | SCS 20525-4D                          | 20,5                                      | 25     | 82  | 85  | 110 | SP..X 060204 | P0220500   | XT07   |          |
| 184048700            | SCS 21025-4D                          | 21,0                                      | 25     | 84  | 87  | 112 | SP..X 060204 | P0220500   | XT07   |          |
| 184048800            | SCS 21525-4D                          | 21,5                                      | 25     | 86  | 89  | 114 | SP..X 060204 | P0220500   | XT07   |          |
| 184048900            | SCS 22032-4D                          | 22,0                                      | 32     | 88  | 91  | 121 | SPKX 07T308  | P0250704   | XT08   |          |
| 184049000            | SCS 22532-4D                          | 22,5                                      | 32     | 90  | 93  | 123 | SPKX 07T308  | P0250704   | XT08   |          |
| 184049100            | SCS 23032-4D                          | 23,0                                      | 32     | 92  | 95  | 125 | SPKX 07T308  | P0250704   | XT08   |          |
| 184049200            | SCS 23532-4D                          | 23,5                                      | 32     | 94  | 97  | 127 | SPKX 07T308  | P0250704   | XT08   |          |
| 184049300            | SCS 24032-4D                          | 24,0                                      | 32     | 96  | 99  | 129 | SPKX 07T308  | P0250704   | XT08   |          |
| 184049400            | SCS 24532-4D                          | 24,5                                      | 32     | 98  | 101 | 131 | SPKX 07T308  | P0250704   | XT08   |          |
| 184049500            | SCS 25032-4D                          | 25,0                                      | 32     | 100 | 103 | 133 | SPKX 07T308  | P0250704   | XT08   |          |
| 184049600            | SCS 25532-4D                          | 25,5                                      | 32     | 102 | 105 | 135 | SPKX 07T308  | P0250704   | XT08   |          |
| 184049700            | SCS 26032-4D                          | 26,0                                      | 32     | 104 | 107 | 137 | SPKX 07T308  | P0250704   | XT08   |          |



 Stock item | Produto de stock | Itens de stock

 Available under request | Disponível sobre consulta | Disponible bajo consulta

Continue next page

# SCS 4D

Jet drills | Brocas jet | Brocas jet

| Order code<br>Código | Reference<br>Referência<br>Referencia | Dimensions   Dimensões   Dimensiones (mm) |        |     |     |     | Insert      | Insert Screw<br> | Torx key<br> | Stock |
|----------------------|---------------------------------------|---|--------|-----|-----|-----|-------------|---|---|-------|
|                      |                                       | DC  | DCONMS | LU  | LCF | LPR |             |   |   |       |
| 184049800            | SCS 26532-4D                          | 26,5                                      | 32     | 106 | 109 | 139 | SPKX 07T308 | P0250704  | XT08  | 📦     |
| 184049900            | SCS 27032-4D                          | 27,0                                      | 32     | 108 | 111 | 141 | SPKX 07T308 | P0250704  | XT08  | 📦     |
| 184050000            | SCS 27532-4D                          | 27,5                                      | 32     | 110 | 113 | 143 | SPKX 07T308 | P0250704  | XT08  | 📦     |
| 184050100            | SCS 28032-4D                          | 28,0                                      | 32     | 112 | 115 | 145 | SPKX 090408 | P0350903  | XT15  | 📦     |
| 184050200            | SCS 28532-4D                          | 28,5                                      | 32     | 114 | 117 | 147 | SPKX 090408 | P0350903  | XT15  | 📦     |
| 184050300            | SCS 29032-4D                          | 29,0                                      | 32     | 116 | 120 | 150 | SPKX 090408 | P0350903  | XT15  | 📦     |
| 184050400            | SCS 29532-4D                          | 29,5                                      | 32     | 118 | 123 | 153 | SPKX 090408 | P0350903  | XT15  | 📦     |
| 184050500            | SCS 30032-4D                          | 30,0                                      | 32     | 120 | 125 | 155 | SPKX 090408 | P0350903  | XT15  | 📦     |
| 184050600            | SCS 31032-4D                          | 31,0                                      | 32     | 124 | 129 | 159 | SPKX 090408 | P0350903  | XT15  | 📦     |
| 184050700            | SCS 32032-4D                          | 32,0                                      | 32     | 128 | 133 | 163 | SPKX 090408 | P0350903  | XT15  | 📦     |
| 184050800            | SCS 33032-4D                          | 33,0                                      | 32     | 132 | 137 | 167 | SPKX 090408 | P0350903  | XT15  | 📦     |
| 184050900            | SCS 34040-4D                          | 34,0                                      | 40     | 136 | 141 | 176 | SPKX 110408 | P0401200  | XT15  | 📦     |
| 184051000            | SCS 35040-4D                          | 35,0                                      | 40     | 140 | 145 | 180 | SPKX 110408 | P0401200  | XT15  | 📦     |
| 184051100            | SCS 36040-4D                          | 36,0                                      | 40     | 144 | 149 | 184 | SPKX 110408 | P0401200  | XT15  | 📦     |
| 184051200            | SCS 37040-4D                          | 37,0                                      | 40     | 148 | 153 | 188 | SPKX 110408 | P0401200  | XT15  | 📦     |
| 184051300            | SCS 38040-4D                          | 38,0                                      | 40     | 152 | 157 | 192 | SPKX 110408 | P0401200  | XT15  | 📦     |
| 184051400            | SCS 39040-4D                          | 39,0                                      | 40     | 156 | 161 | 196 | SPKX 110408 | P0401200  | XT15  | 📦     |
| 184051500            | SCS 40040-4D                          | 40,0                                      | 40     | 160 | 165 | 200 | SPKX 110408 | P0401200  | XT15  | 📦     |
| 184051600            | SCS 41040-4D                          | 41,0                                      | 40     | 164 | 169 | 204 | SPKX 110408 | P0401200  | XT15  | 📦     |
| 184051700            | SCS 42040-4D                          | 42,0                                      | 40     | 168 | 173 | 208 | SPKX 140512 | P0501300  | XT20  | 📦     |
| 184051800            | SCS 43040-4D                          | 43,0                                      | 40     | 172 | 177 | 212 | SPKX 140512 | P0501300  | XT20  | 📦     |
| 184051900            | SCS 44040-4D                          | 44,0                                      | 40     | 176 | 181 | 216 | SPKX 140512 | P0501300  | XT20  | 📦     |
| 184052000            | SCS 45040-4D                          | 45,0                                      | 40     | 180 | 185 | 220 | SPKX 140512 | P0501300  | XT20  | 📦     |
| 184052100            | SCS 46040-4D                          | 46,0                                      | 40     | 184 | 189 | 224 | SPKX 140512 | P0501300  | XT20  | 📦     |
| 184052200            | SCS 47040-4D                          | 47,0                                      | 40     | 188 | 193 | 228 | SPKX 140512 | P0501300  | XT20  | 📦     |
| 184052300            | SCS 48040-4D                          | 48,0                                      | 40     | 192 | 197 | 232 | SPKX 140512 | P0501300  | XT20  | 📦     |
| 184052400            | SCS 49040-4D                          | 49,0                                      | 40     | 196 | 201 | 236 | SPKX 140512 | P0501300  | XT20  | 📦     |
| 184052500            | SCS 50040-4D                          | 50,0                                      | 40     | 200 | 205 | 240 | SPKX 140512 | P0501300  | XT20  | 📦     |

📦 Stock item | Produto de stock | Itens de stock







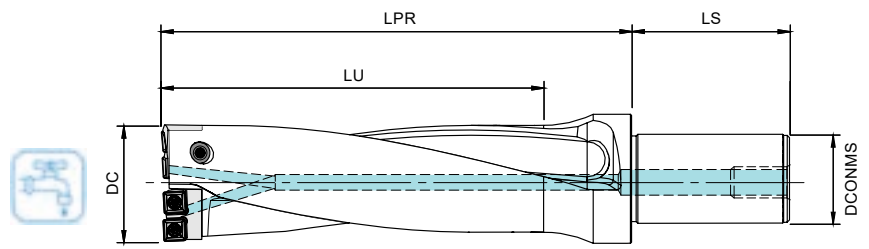

○ Available under request | Disponível sobre consulta | Disponible bajo consulta

# SCC 3D CARTRIDGE TYPE (DOUBLE INSERT) Jet drills | Brocas jet | Brocas jet

SIZE ADAPTABLE CARTRIDGE (5MM)



| DCONMS | LS | BP / SP  |
|--------|----|----------|
| 40     | 70 | PT - 1/4 |

| Order code<br>Código | Reference<br>Referência<br>Referencia | Dimensions   Dimensões   Dimensiones (mm) |        |     |     | Cartridge      | Insert      | Insert Screw   | Torx key   | Stock   |
|----------------------|---------------------------------------|---|--------|-----|-----|----------------|-------------|--|--|---|
|                      |                                       | DC  | DCONMS | LU  | LPR |                |             |  |  |   |
| 184231800            | SCC 505540-3D                         | 50-55                                     | 40     | 165 | 205 | SCC 050055-I/O | SPKX 090408 | P0350903   | XT15   |  |
| 184231900            | SCC 556040-3D                         | 55-60                                     | 40     | 180 | 220 | SCC 055060-I/O | SPKX 090408 | P0350903   | XT15   |  |
| 184232000            | SCC 606540-3D                         | 60-65                                     | 40     | 195 | 235 | SCC 060065-I/O | SPKX 110408 | P0401200   | XT15   |  |
| 184232100            | SCC 657040-3D                         | 65-70                                     | 40     | 210 | 250 | SCC 065070-I/O | SPKX 110408 | P0401200   | XT15   |  |
| 184232200            | SCC 707540-3D                         | 70-75                                     | 40     | 225 | 265 | SCC 070075-I/O | SPKX 110408 | P0401200   | XT15   |  |
| 184232300            | SCC 758040-3D                         | 75-80                                     | 40     | 240 | 278 | SCC 075080-I/O | SPKX 140512 | P0501300   | XT20   |  |

 Stock item | Produto de stock | Itens de stock







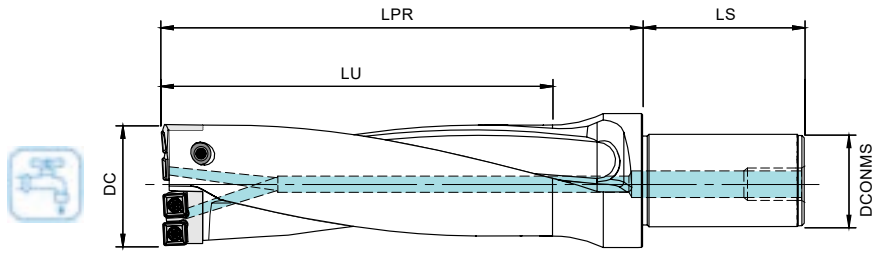

 Available under request | Disponível sobre consulta | Disponible bajo consulta

# SCC 4D CARTRIDGE TYPE (DOUBLE INSERT) Jet drills | Brocas jet | Brocas jet

SIZE ADAPTABLE CARTRIDGE (5MM)



| DCONMS | LS | BP / SP  |
|--------|----|----------|
| 40     | 70 | PT - 1/4 |





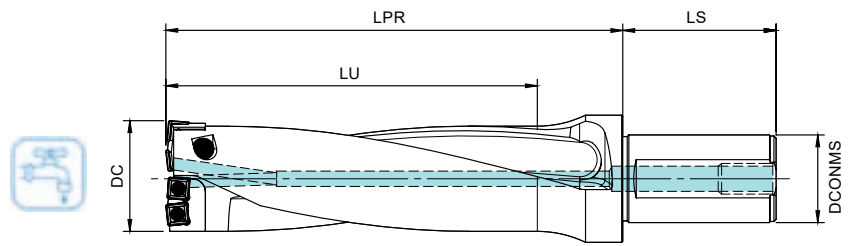

| Order code<br>Código | Reference<br>Referência<br>Referencia | Dimensions   Dimensões   Dimensiones (mm) |        |     |     | Cartridge      | Insert      | Insert Screw<br> | Torx key<br> | Stock   |
|----------------------|---------------------------------------|---|--------|-----|-----|----------------|-------------|--|--|---|
|                      |                                       | DC  | DCONMS | LU  | LPR |                |             |  |  |   |
| 184232400            | SCC 505540-4D                         | 50-55                                     | 40     | 220 | 260 | SCC 050055-I/O | SPKX 090408 | P0350903   | XT15   |  |
| 184232500            | SCC 556040-4D                         | 55-60                                     | 40     | 240 | 280 | SCC 055060-I/O | SPKX 090408 | P0350903   | XT15   |  |
| 184232600            | SCC 606540-4D                         | 60-65                                     | 40     | 260 | 300 | SCC 060065-I/O | SPKX 110408 | P0401200   | XT15   |  |
| 184232700            | SCC 657040-4D                         | 65-70                                     | 40     | 280 | 320 | SCC 065070-I/O | SPKX 110408 | P0401200   | XT15   |  |
| 184232800            | SCC 707540-4D                         | 70-75                                     | 40     | 300 | 340 | SCC 070075-I/O | SPKX 110408 | P0401200   | XT15   |  |
| 184232900            | SCC 758040-4D                         | 75-80                                     | 40     | 320 | 358 | SCC 075080-I/O | SPKX 140512 | P0501300   | XT20   |  |

 Stock item | Produto de stock | Itens de stock

 Available under request | Disponível sobre consulta | Disponible bajo consulta



| DCONMS | LS | BP / SP  |
|--------|----|----------|
| 40     | 70 | PT - 1/4 |







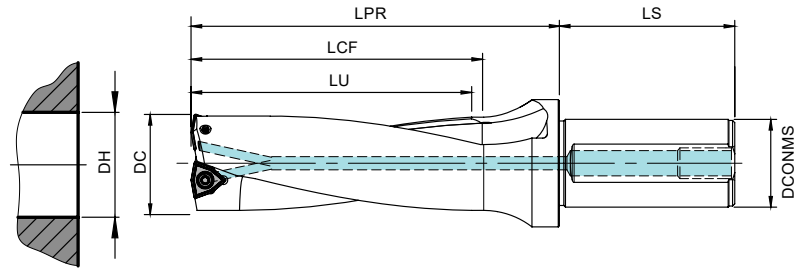























| Order code<br>Código | Reference<br>Referência<br>Referencia | Dimensions   Dimensões   Dimensiones (mm) |        |     |     | Cartridge             | Insert      | Insert Screw   | Torx key   | Stock   |
|----------------------|---------------------------------------|---|--------|-----|-----|-----------------------|-------------|--|--|---|
|                      |                                       | DC  | DCONMS | LU  | LPR |                       |             |  |  |   |
| 184056300            | SCC 575840-4D                         | 57-58                                     | 40     | 235 | 275 | CISP 5560 / COSP 5758 | SPKX 090408 | P0350903   | XT15   |  |
| 184056400            | SCC 585940-4D                         | 58-59                                     | 40     | 235 | 275 | CISP 5560 / COSP 5859 | SPKX 090408 | P0350903   | XT15   |  |
| 184056500            | SCC 596040-4D                         | 59-60                                     | 40     | 235 | 275 | CISP 5560 / COSP 5960 | SPKX 090408 | P0350903   | XT15   |  |
| 184057400            | SCC 686940-4D                         | 68-69                                     | 40     | 275 | 315 | CISP 6570 / COSP 6869 | SPKX 110408 | P0401200   | XT15   |  |

 Stock item | Produto de stock | Itens de stock     Available under request | Disponível sobre consulta | Disponible bajo consulta     Available until sold out | Disponível até acabar o stock | Disponible hasta acabar el stock

\* The 1mm size adjustment cartridge will be replaced by the 5mm adaptable cartridge when this type is sold out. See previous page for the new Drill version.





| DCONMS | LS | BP / SP | ØDH tolerance (mm) |               |
|--------|----|---------|--------------------|---------------|
|        |    |         | DC                 | 3D            |
| 20     | 50 | PT-1/8  |                    |               |
| 25     | 56 | PT-1/8  | 13,0 - 21,5        | -0,10 / +0,15 |
| 32     | 60 | PT-1/4  | 22,0 - 50,0        | -0,12 / +0,20 |
| 40     | 70 | PT-1/4  | 50,0 - 58,0        | -0,15 / +0,25 |

| Order code<br>Código | Reference<br>Referência<br>Referencia | Dimensions   Dimensões   Dimensiones (mm) |        |    |     |     | Insert      | Insert Screw<br> | Torx key<br> | Stock<br> |
|----------------------|---------------------------------------|---|--------|----|-----|-----|-------------|---|---|--|
|                      |                                       | DC  | DCONMS | LU | LCF | LPR |             |   |   |  |
| 184034600            | TDS 13020-3D                          | 13,0                                      | 20     | 39 | 42  | 62  | WCKX 02T104 | P0180500  | XT06  |         |
| 184034700            | TDS 13520-3D                          | 13,5                                      | 20     | 41 | 44  | 64  | WCKX 02T104 | P0180500  | XT06  |         |
| 184034800            | TDS 14020-3D                          | 14,0                                      | 20     | 42 | 45  | 65  | WCKX 02T104 | P0180500  | XT06  |         |
| 184034900            | TDS 14520-3D                          | 14,5                                      | 20     | 44 | 47  | 67  | WCKX 02T104 | P0180500  | XT06  |         |
| 184035000            | TDS 15020-3D                          | 15,0                                      | 20     | 45 | 48  | 68  | WCKX 02T104 | P0180500  | XT06  |         |
| 184035100            | TDS 15520-3D                          | 15,5                                      | 20     | 47 | 50  | 70  | WCKX 02T104 | P0180500  | XT06  |         |
| 184035200            | TDS 16025-3D                          | 16,0                                      | 25     | 48 | 51  | 76  | WCKX 030204 | P0220500  | XT07  |         |
| 184035300            | TDS 16525-3D                          | 16,5                                      | 25     | 50 | 53  | 78  | WCKX 030204 | P0220500  | XT07  |         |
| 184035400            | TDS 17025-3D                          | 17,0                                      | 25     | 51 | 54  | 79  | WCKX 030204 | P0220500  | XT07  |         |
| 184035500            | TDS 17525-3D                          | 17,5                                      | 25     | 53 | 56  | 81  | WCKX 030204 | P0220500  | XT07  |         |
| 184035600            | TDS 18025-3D                          | 18,0                                      | 25     | 54 | 57  | 82  | WCKX 030204 | P0220500  | XT07  |         |
| 184035700            | TDS 18525-3D                          | 18,5                                      | 25     | 56 | 59  | 84  | WCKX 030204 | P0220500  | XT07  |         |
| 184035800            | TDS 19025-3D                          | 19,0                                      | 25     | 57 | 60  | 85  | WCKX 030204 | P0220500  | XT07  |         |
| 184035900            | TDS 19525-3D                          | 19,5                                      | 25     | 59 | 62  | 87  | WCKX 030204 | P0220500  | XT07  |         |
| 184036000            | TDS 20025-3D                          | 20,0                                      | 25     | 60 | 63  | 88  | WCKX 030204 | P0220500  | XT07  |         |
| 184036100            | TDS 20525-3D                          | 20,5                                      | 25     | 62 | 65  | 90  | WCKX 040204 | P0250503  | XT08  |         |
| 184036200            | TDS 21025-3D                          | 21,0                                      | 25     | 63 | 66  | 91  | WCKX 040204 | P0250503  | XT08  |         |
| 184036300            | TDS 21525-3D                          | 21,5                                      | 25     | 65 | 68  | 93  | WCKX 040204 | P0250503  | XT08  |         |
| 184036400            | TDS 22025-3D                          | 22,0                                      | 25     | 66 | 69  | 94  | WCKX 040204 | P0250503  | XT08  |         |
| 184036500            | TDS 22525-3D                          | 22,5                                      | 25     | 68 | 71  | 96  | WCKX 040204 | P0250503  | XT08  |         |
| 184036600            | TDS 23025-3D                          | 23,0                                      | 25     | 69 | 72  | 97  | WCKX 040204 | P0250503  | XT08  |         |
| 184036700            | TDS 23525-3D                          | 23,5                                      | 25     | 71 | 74  | 99  | WCKX 040204 | P0250503  | XT08  |         |
| 184036800            | TDS 24025-3D                          | 24,0                                      | 25     | 72 | 75  | 100 | WCKX 040204 | P0250503  | XT08  |         |
| 184036900            | TDS 24525-3D                          | 24,5                                      | 25     | 74 | 77  | 102 | WCKX 040204 | P0250503  | XT08  |         |
| 184037000            | TDS 25025-3D                          | 25,0                                      | 25     | 75 | 78  | 103 | WCKX 040204 | P0250503  | XT08  |         |
| 184037100            | TDS 25532-3D                          | 25,5                                      | 32     | 77 | 80  | 110 | WCKX 050308 | P0300701  | XT08  |         |
| 184037200            | TDS 26032-3D                          | 26,0                                      | 32     | 78 | 81  | 111 | WCKX 050308 | P0300701  | XT08  |         |

 Stock item | Produto de stock | Itens de stock

 Available under request | Disponível sobre consulta | Disponible bajo consulta

Continue next page

| Order code<br>Código | Reference<br>Referência<br>Referencia | Dimensions   Dimensões   Dimensiones (mm) |        |     |     |     | Insert      | Insert Screw<br> | Torx key<br> | Stock |
|----------------------|---------------------------------------|---|--------|-----|-----|-----|-------------|---|---|-------|
|                      |                                       | DC  | DCONMS | LU  | LCF | LPR |             |   |   |       |
| 184037300            | TDS 26532-3D                          | 26,5                                      | 32     | 80  | 83  | 113 | WCKX 050308 | P0300701  | XT08  | 📦     |
| 184037400            | TDS 27032-3D                          | 27,0                                      | 32     | 81  | 84  | 114 | WCKX 050308 | P0300701  | XT08  | 📦     |
| 184037500            | TDS 27532-3D                          | 27,5                                      | 32     | 83  | 86  | 116 | WCKX 050308 | P0300701  | XT08  | 📦     |
| 184037600            | TDS 28032-3D                          | 28,0                                      | 32     | 84  | 87  | 117 | WCKX 050308 | P0300701  | XT08  | 📦     |
| 184037700            | TDS 28532-3D                          | 28,5                                      | 32     | 86  | 89  | 119 | WCKX 050308 | P0300701  | XT08  | 📦     |
| 184037800            | TDS 29032-3D                          | 29,0                                      | 32     | 87  | 90  | 120 | WCKX 050308 | P0300701  | XT08  | 📦     |
| 184037900            | TDS 29532-3D                          | 29,5                                      | 32     | 89  | 92  | 122 | WCKX 050308 | P0300701  | XT08  | 📦     |
| 184038000            | TDS 30032-3D                          | 30,0                                      | 32     | 90  | 93  | 123 | WCKX 050308 | P0300701  | XT08  | 📦     |
| 184038100            | TDS 31032-3D                          | 31,0                                      | 32     | 93  | 96  | 126 | WCKX 06T308 | P0350903  | XT15  | 📦     |
| 184038200            | TDS 32032-3D                          | 32,0                                      | 32     | 96  | 99  | 129 | WCKX 06T308 | P0350903  | XT15  | 📦     |
| 184038300            | TDS 33032-3D                          | 33,0                                      | 32     | 99  | 102 | 132 | WCKX 06T308 | P0350903  | XT15  | 📦     |
| 184038400            | TDS 34032-3D                          | 34,0                                      | 32     | 102 | 105 | 135 | WCKX 06T308 | P0350903  | XT15  | 📦     |
| 184038500            | TDS 35032-3D                          | 35,0                                      | 32     | 105 | 108 | 138 | WCKX 06T308 | P0350903  | XT15  | 📦     |
| 184038600            | TDS 36032-3D                          | 36,0                                      | 32     | 108 | 111 | 141 | WCKX 06T308 | P0350903  | XT15  | 📦     |
| 184038700            | TDS 37032-3D                          | 37,0                                      | 32     | 111 | 114 | 144 | WCKX 06T308 | P0350903  | XT15  | 📦     |
| 184038800            | TDS 38032-3D                          | 38,0                                      | 32     | 114 | 117 | 147 | WCKX 06T308 | P0350903  | XT15  | 📦     |
| 184038900            | TDS 39032-3D                          | 39,0                                      | 32     | 117 | 120 | 150 | WCKX 06T308 | P0350903  | XT15  | 📦     |
| 184039000            | TDS 40032-3D                          | 40,0                                      | 32     | 120 | 123 | 153 | WCKX 06T308 | P0350903  | XT15  | 📦     |
| 184039100            | TDS 41032-3D                          | 41,0                                      | 32     | 123 | 126 | 156 | WCKX 06T308 | P0350903  | XT15  | 📦     |
| 184039200            | TDS 42040-3D                          | 42,0                                      | 40     | 126 | 129 | 164 | WCKX 080408 | P0401101  | XT15  | 📦     |
| 184039300            | TDS 43040-3D                          | 43,0                                      | 40     | 129 | 132 | 167 | WCKX 080408 | P0401101  | XT15  | 📦     |
| 184039400            | TDS 44040-3D                          | 44,0                                      | 40     | 132 | 135 | 170 | WCKX 080408 | P0401101  | XT15  | 📦     |
| 184039500            | TDS 45040-3D                          | 45,0                                      | 40     | 135 | 138 | 173 | WCKX 080408 | P0401101  | XT15  | 📦     |
| 184039600            | TDS 46040-3D                          | 46,0                                      | 40     | 138 | 141 | 176 | WCKX 080408 | P0401101  | XT15  | 📦     |
| 184039700            | TDS 47040-3D                          | 47,0                                      | 40     | 141 | 144 | 179 | WCKX 080408 | P0401101  | XT15  | 📦     |
| 184039800            | TDS 48040-3D                          | 48,0                                      | 40     | 144 | 147 | 182 | WCKX 080408 | P0401101  | XT15  | 📦     |
| 184039900            | TDS 49040-3D                          | 49,0                                      | 40     | 147 | 150 | 185 | WCKX 080408 | P0401101  | XT15  | 📦     |
| 184040000            | TDS 50040-3D                          | 50,0                                      | 40     | 150 | 153 | 188 | WCKX 080408 | P0401101  | XT15  | 📦     |
| 184040100            | TDS 51040-3D                          | 51,0                                      | 40     | 153 | 156 | 191 | WCKX 080408 | P0401101  | XT15  | 📦     |
| 184040200            | TDS 52040-3D                          | 52,0                                      | 40     | 156 | 159 | 194 | WCKX 080408 | P0401101  | XT15  | 📦     |
| 184040300            | TDS 53040-3D                          | 53,0                                      | 40     | 159 | 162 | 197 | WCKX 080408 | P0401101  | XT15  | 📦     |
| 184040400            | TDS 54040-3D                          | 54,0                                      | 40     | 162 | 165 | 200 | WCKX 080408 | P0401101  | XT15  | 📦     |
| 184040500            | TDS 55040-3D                          | 55,0                                      | 40     | 165 | 168 | 203 | WCKX 080408 | P0401101  | XT15  | 📦     |
| 184040600            | TDS 56040-3D                          | 56,0                                      | 40     | 168 | 171 | 206 | WCKX 080408 | P0401101  | XT15  | 📦     |
| 184040700            | TDS 57040-3D                          | 57,0                                      | 40     | 171 | 174 | 209 | WCKX 080408 | P0401101  | XT15  | 📦     |
| 184040800            | TDS 58040-3D                          | 58,0                                      | 40     | 174 | 177 | 212 | WCKX 080408 | P0401101  | XT15  | 📦     |



📦 Stock item | Produto de stock | Itens de stock

○ Available under request | Disponível sobre consulta | Disponible bajo consulta

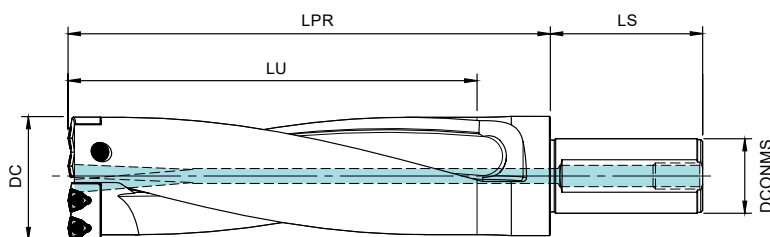
# TDC 3D CARTRIDGE TYPE (DOUBLE INSERT) Jet drills | Brocas jet | Brocas jet



|        |    |          |
|--------|----|----------|
| DCONMS | LS | BP / SP  |
| 40     | 70 | PT - 1/4 |

| Order code<br>Código | Reference<br>Referência<br>Referencia | Dimensions   Dimensões   Dimensiones (mm) |        |     |     |                | Insert      | Insert Screw<br> | Torx key<br> | Stock   |
|----------------------|---------------------------------------|---|--------|-----|-----|----------------|-------------|---|---|---|
|                      |                                       | DC  | DCONMS | LU  | LPR | Cartridge      |             |   |   |   |
| 184040900            | TDC 596540-3D                         | 59-65                                     | 40     | 195 | 235 | TDC 059065-I/O | WCKX 06T308 | P0350903  | XT15  |  |
| 184041000            | TDC 657040-3D                         | 65-70                                     | 40     | 210 | 250 | TDC 065070-I/O | WCKX 06T308 | P0350903  | XT15  |  |
| 184041100            | TDC 707540-3D                         | 70-75                                     | 40     | 225 | 265 | TDC 070075-I/O | WCKX 06T308 | P0350903  | XT15  |  |
| 184041200            | TDC 758040-3D                         | 75-80                                     | 40     | 240 | 280 | TDC 075080-I/O | WCKX 06T308 | P0350903  | XT15  |  |

 Stock item | Produto de stock | Itens de stock

 Available under request | Disponível sobre consulta | Disponible bajo consulta

# INTEGREX

## DRILLS



Integrex drills offer an indexable insert solution that includes a pilot drill, making them highly effective for drilling holes with considerable cutting lengths. The pilot drill functions to create a clean and consistent working surface, enabling the subsequent drill to enter the workpiece smoothly and also acting as a guide throughout the drilling operation.

As brocas Integrex oferecem uma solução de inserção indexável que inclui uma broca piloto, tornando-as eficazes para perfurar com comprimentos de corte consideráveis. A broca piloto funciona para criar uma superfície de trabalho limpa e consistente, permitindo que a broca subsequente entre na peça suavemente e também atuando como um guia durante toda a operação de perfuração.

Las brocas Integrex ofrecen una solución de inserción indexable que incluye una broca piloto, lo que las hace efectivas para perforar con longitudes de corte considerable. La broca piloto funciona para crear una superficie de trabajo limpia y consistente, permitiendo que la broca posterior entre en la pieza suavemente y también actuando como guía durante toda la operación de perforación.

## DHS > page 406

- > From DC 25mm to 40mm  
De DC 25mm a 40mm | Desde DC 25mm hasta 40mm
- > Available in 5D and 8D  
Disponível em 5D e 8D | Disponible en 5D y 8D
- > Insert WCKX  
Pastilha WCKX | Plaquita WCKX
- > Pilot drill  
Broca piloto | Taladro piloto



## DHC > page 408

- > From DC 41mm to 80mm  
De DC 41mm a 80mm | Desde DC 41mm hasta 80mm
- > Available in 5D and 8D  
Disponível em 5D e 8D | Disponible en 5D y 8D
- > 1 or 2 WCKX inserts per cartridge  
1 ou 2 pastilhas WCKX por cartucho | 1 o 2 plaquitas WCKX por cartucho
- > Pilot drill  
Broca piloto | Taladro piloto



## TFD > page 410

- > From DC 18,0mm to 30,0mm  
De DC 18,0mm a 30,0mm | Desde DC 18,0mm hasta 30,0mm
- > Available in 6D and 8D  
Disponível em 6D e 8D | Disponible en 6D y 8D
- > Insert SPKX  
Pastilha SPKX | Plaquita SPKX
- > Pilot drill  
Broca piloto | Taladro piloto



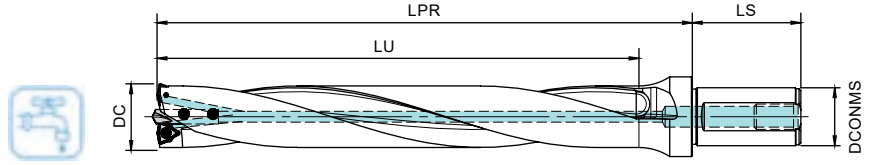



New version / Standard version\*

| DCONMS | LS      | BP / SP  |
|--------|---------|----------|
| 32     | 60 / 70 | PT - 1/4 |

\*Order separately

| Order code<br>Código | Reference<br>Referência<br>Referencia | Dimensions   Dimensões   Dimensiones (mm) |        |     |     | Insert      | Insert Screw<br> | Torx key<br> | Pilot drill*<br> | Stock |
|----------------------|---------------------------------------|---|--------|-----|-----|-------------|--|--|--|-------|
|                      |                                       | DC  | DCONMS | LU  | LPR |             |  |  |  |       |
| 184058600            | DHS 002532-5D                         | 25  | 32     | 150 | 180 | WCKX 030204 | P0220500   | XT07   | MDP 3006   | ○     |
| 184058700            | DHS 002632-5D                         | 26  | 32     | 150 | 180 | WCKX 040204 | P0250503   | XT08   | MDP 3006   | ○     |
| 184058800            | DHS 002732-5D                         | 27  | 32     | 150 | 180 | WCKX 040204 | P0250503   | XT08   | MDP 3006   | ○     |
| 184058900            | DHS 002832-5D                         | 28  | 32     | 150 | 180 | WCKX 040204 | P0250503   | XT08   | MDP 3006   | ○     |
| 184059000            | DHS 002932-5D                         | 29  | 32     | 150 | 180 | WCKX 040204 | P0250503   | XT08   | MDP 3006   | ○     |
| 184059100            | DHS 003032-5D                         | 30  | 32     | 150 | 180 | WCKX 040204 | P0250503   | XT08   | MDP 3006   | ○     |
| 184059200            | DHS 003132-5D                         | 31  | 32     | 175 | 205 | WCKX 050308 | P0300701   | XT08   | MDP 3508   | ○     |
| 184059300            | DHS 003232-5D                         | 32  | 32     | 175 | 205 | WCKX 050308 | P0300701   | XT08   | MDP 3508   | ○     |
| 184059400            | DHS 003332-5D                         | 33  | 32     | 175 | 205 | WCKX 050308 | P0300701   | XT08   | MDP 3508   | ○     |
| 184059500            | DHS 003432-5D                         | 34  | 32     | 175 | 205 | WCKX 050308 | P0300701   | XT08   | MDP 3508   | ○     |
| 184059600            | DHS 003532-5D                         | 35  | 32     | 175 | 205 | WCKX 050308 | P0300701   | XT08   | MDP 3508   | ○     |
| 184059700            | DHS 003632-5D                         | 36  | 32     | 200 | 230 | WCKX 050308 | P0300701   | XT08   | MDP 3508   | ○     |
| 184059800            | DHS 003732-5D                         | 37  | 32     | 200 | 230 | WCKX 050308 | P0300701   | XT08   | MDP 3508   | ○     |
| 184059900            | DHS 003832-5D                         | 38  | 32     | 200 | 230 | WCKX 050308 | P0300701   | XT08   | MDP 3508   | ○     |
| 184060000            | DHS 003932-5D                         | 39  | 32     | 200 | 230 | WCKX 050308 | P0300701   | XT08   | MDP 3508   | ○     |
| 184060100            | DHS 004032-5D                         | 40  | 32     | 200 | 230 | WCKX 050308 | P0300701   | XT08   | MDP 3508   | ○     |

⊗ Stock item | Produto de stock | Itens de stock      ○ Available under request | Disponível sobre consulta | Disponible bajo consulta

**Note:** This type of drills are supplied without pilot drills. Please order them separately.

Please see Page B - 449 for setting pilot drill.

Pilot Drill  
mounting procedure



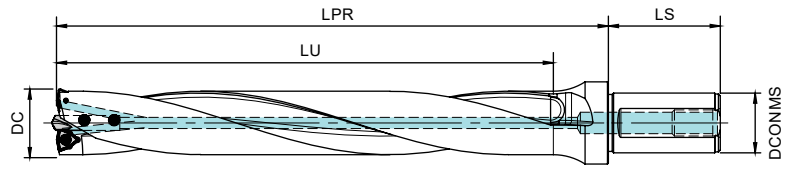



New version / Standard version\*

| DCONMS | LS      | BP / SP  |
|--------|---------|----------|
| 32     | 60 / 70 | PT - 1/4 |

\*Order separately

| Order code<br>Código | Reference<br>Referência<br>Referencia | Dimensions   Dimensões   Dimensiones (mm) |        |     |     | Insert      | Insert Screw<br> | Torx key<br> | Pilot drill*<br> | Stock |
|----------------------|---------------------------------------|---|--------|-----|-----|-------------|--|--|--|-------|
|                      |                                       | DC  | DCONMS | LU  | LPR |             |  |  |  |       |
| 184062100            | DHS 002532-8D                         | 25  | 32     | 220 | 250 | WCKX 030204 | P0220500   | XT07   | MDP 3006   | ⊗     |
| 184062200            | DHS 002632-8D                         | 26  | 32     | 220 | 250 | WCKX 040204 | P0250503   | XT08   | MDP 3006   | ○     |
| 184062300            | DHS 002732-8D                         | 27  | 32     | 220 | 250 | WCKX 040204 | P0250503   | XT08   | MDP 3006   | ○     |
| 184062400            | DHS 002832-8D                         | 28  | 32     | 220 | 250 | WCKX 040204 | P0250503   | XT08   | MDP 3006   | ○     |
| 184062500            | DHS 002932-8D                         | 29  | 32     | 220 | 250 | WCKX 040204 | P0250503   | XT08   | MDP 3006   | ○     |
| 184062600            | DHS 003032-8D                         | 30  | 32     | 220 | 250 | WCKX 040204 | P0250503   | XT08   | MDP 3006   | ⊗     |
| 184062700            | DHS 003132-8D                         | 31  | 32     | 260 | 290 | WCKX 050308 | P0300701   | XT08   | MDP 3508   | ○     |
| 184062800            | DHS 003232-8D                         | 32  | 32     | 260 | 290 | WCKX 050308 | P0300701   | XT08   | MDP 3508   | ○     |
| 184062900            | DHS 003332-8D                         | 33  | 32     | 260 | 290 | WCKX 050308 | P0300701   | XT08   | MDP 3508   | ○     |
| 184063000            | DHS 003432-8D                         | 34  | 32     | 260 | 290 | WCKX 050308 | P0300701   | XT08   | MDP 3508   | ⊗     |
| 184063100            | DHS 003532-8D                         | 35  | 32     | 260 | 290 | WCKX 050308 | P0300701   | XT08   | MDP 3508   | ⊗     |
| 184063200            | DHS 003632-8D                         | 36  | 32     | 300 | 330 | WCKX 050308 | P0300701   | XT08   | MDP 3508   | ○     |
| 184063300            | DHS 003732-8D                         | 37  | 32     | 300 | 330 | WCKX 050308 | P0300701   | XT08   | MDP 3508   | ○     |
| 184063400            | DHS 003832-8D                         | 38  | 32     | 300 | 330 | WCKX 050308 | P0300701   | XT08   | MDP 3508   | ○     |
| 184063500            | DHS 003932-8D                         | 39  | 32     | 300 | 330 | WCKX 050308 | P0300701   | XT08   | MDP 3508   | ○     |
| 184063600            | DHS 004032-8D                         | 40  | 32     | 300 | 330 | WCKX 050308 | P0300701   | XT08   | MDP 3508   | ⊗     |

⊗ Stock item | Produto de stock | Itens de stock      ○ Available under request | Disponível sobre consulta | Disponible bajo consulta

Note: This type of drills are supplied without pilot drills. Please order them separately.

Please see Page B - 449 for setting pilot drill.

Pilot Drill  
mounting procedure



# DHC 5D CARTRIDGE TYPE (SINGLE & DOUBLE INSERT)

Integrex drills | Brocas integrex | Brocas integrex

HOLEMAKING

Multi cut

Jet Drills

Integrex Drills

Vortex Drills

Trepanning Drills

Inserts

Spare Parts

Technical Data

Solid Carbide Drills

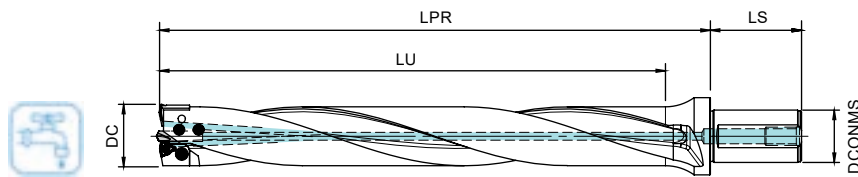

New version / Standard version\*

| DCONMS | LS      | BP / SP  |
|--------|---------|----------|
| 40     | 70 / 80 | PT - 1/4 |

\*Order separately

| Order code<br>Código | Reference<br>Referência<br>Referencia | Dimensions<br>Dimensões<br>Dimensiones (mm) |        |    |     | Cartridge | Insert | Insert Screw | Torx key | Pilot drill* | Stock |
|----------------------|---------------------------------------|---|--------|----|-----|-----------|--------|--------------|----------|--------------|-------|
|                      |                                       | DC  | DCONMS | LU | LPR |           |        |              |          |              |       |

1 INSERT PER CARTRIDGE

|           |               |    |    |     |     |                             |             |          |      |          |   |
|-----------|---------------|----|----|-----|-----|-----------------------------|-------------|----------|------|----------|---|
| 184192500 | DHC 004140-5D | 41 | 40 | 225 | 260 | CWC 041045-I / CWC 000041-O | WCKX 06T308 | P0350903 | XT15 | MDP 3510 | ○ |
| 184192600 | DHC 004240-5D | 42 | 40 | 225 | 260 | CWC 041045-I / CWC 000042-O | WCKX 06T308 | P0350903 | XT15 | MDP 3510 | ○ |
| 184192700 | DHC 004340-5D | 43 | 40 | 225 | 260 | CWC 041045-I / CWC 000043-O | WCKX 06T308 | P0350903 | XT15 | MDP 3510 | ○ |
| 184192800 | DHC 004440-5D | 44 | 40 | 225 | 260 | CWC 041045-I / CWC 000044-O | WCKX 06T308 | P0350903 | XT15 | MDP 3510 | ○ |
| 184192900 | DHC 004540-5D | 45 | 40 | 225 | 260 | CWC 041045-I / CWC 000045-O | WCKX 06T308 | P0350903 | XT15 | MDP 3510 | ○ |
| 184193000 | DHC 004640-5D | 46 | 40 | 250 | 285 | CWC 046050-I / CWC 000046-O | WCKX 06T308 | P0350903 | XT15 | MDP 3510 | ○ |
| 184193100 | DHC 004740-5D | 47 | 40 | 250 | 285 | CWC 046050-I / CWC 000047-O | WCKX 06T308 | P0350903 | XT15 | MDP 3510 | ○ |
| 184193200 | DHC 004840-5D | 48 | 40 | 250 | 285 | CWC 046050-I / CWC 000048-O | WCKX 06T308 | P0350903 | XT15 | MDP 3510 | ○ |
| 184193300 | DHC 004940-5D | 49 | 40 | 250 | 285 | CWC 046050-I / CWC 000049-O | WCKX 06T308 | P0350903 | XT15 | MDP 3510 | ○ |
| 184193400 | DHC 005040-5D | 50 | 40 | 250 | 285 | CWC 046050-I / CWC 000050-O | WCKX 06T308 | P0350903 | XT15 | MDP 3510 | ○ |
| 184193500 | DHC 005140-5D | 51 | 40 | 275 | 310 | CWC 051055-I / CWC 000051-O | WCKX 080408 | P0401101 | XT15 | MDP 3812 | ○ |
| 184193600 | DHC 005240-5D | 52 | 40 | 275 | 310 | CWC 051055-I / CWC 000052-O | WCKX 080408 | P0401101 | XT15 | MDP 3812 | ○ |
| 184193700 | DHC 005340-5D | 53 | 40 | 275 | 310 | CWC 051055-I / CWC 000053-O | WCKX 080408 | P0401101 | XT15 | MDP 3812 | ○ |
| 184193800 | DHC 005440-5D | 54 | 40 | 275 | 310 | CWC 051055-I / CWC 000054-O | WCKX 080408 | P0401101 | XT15 | MDP 3812 | ○ |
| 184193900 | DHC 005540-5D | 55 | 40 | 275 | 310 | CWC 051055-I / CWC 000055-O | WCKX 080408 | P0401101 | XT15 | MDP 3812 | ○ |
| 184194000 | DHC 005640-5D | 56 | 40 | 300 | 335 | CWC 056059-I / CWC 000056-O | WCKX 080408 | P0401101 | XT15 | MDP 3812 | ○ |
| 184194100 | DHC 005740-5D | 57 | 40 | 300 | 335 | CWC 056059-I / CWC 000057-O | WCKX 080408 | P0401101 | XT15 | MDP 3812 | ○ |
| 184194200 | DHC 005840-5D | 58 | 40 | 300 | 335 | CWC 056059-I / CWC 000058-O | WCKX 080408 | P0401101 | XT15 | MDP 3812 | ○ |
| 184194300 | DHC 005940-5D | 59 | 40 | 300 | 335 | CWC 056059-I / CWC 000059-O | WCKX 080408 | P0401101 | XT15 | MDP 3812 | ○ |

2 INSERTS PER CARTRIDGE

|           |               |       |    |     |     |                |             |          |      |          |   |
|-----------|---------------|-------|----|-----|-----|----------------|-------------|----------|------|----------|---|
| 184065600 | DHC 606540-5D | 60-65 | 40 | 325 | 360 | MDC 060065-I/O | WCKX 050308 | P0300701 | XT08 | MDP 3812 | ○ |
| 184065700 | DHC 657040-5D | 65-70 | 40 | 350 | 385 | MDC 065070-I/O | WCKX 050308 | P0300701 | XT08 | MDP 3812 | ○ |
| 184065800 | DHC 707540-5D | 70-75 | 40 | 375 | 410 | MDC 070075-I/O | WCKX 050308 | P0300701 | XT08 | MDP 3812 | ○ |
| 184065900 | DHC 758040-5D | 75-80 | 40 | 400 | 435 | MDC 075080-I/O | WCKX 06T308 | P0350903 | XT15 | MDP 4516 | ○ |

⊗ Stock item | Produto de stock | Itens de stock      ○ Available under request | Disponível sobre consulta | Disponible bajo consulta

Note: This type of drills are supplied without pilot drills. Please order them separately.

Please see Page B - 449 for setting pilot drill.

Pilot Drill  
mounting procedure



# DHC 8D CARTRIDGE TYPE (SINGLE & DOUBLE INSERT)

Integrex drills | Brocas integrex | Brocas integrex

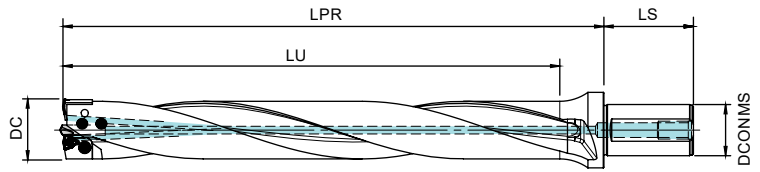

New version / Standard version\*

| DCONMS | LS      | BP / SP  |
|--------|---------|----------|
| 40     | 70 / 80 | PT - 1/4 |

\*Order separately

| Order code<br>Código    | Reference<br>Referência | Dimensions<br>Dimensões<br>Dimensiones (mm) |        |     |     | Cartridge                   | Insert      | Insert<br>Screw | Torx<br>key | Pilot drill* | Stock |
|-------------------------|-------------------------|---|--------|-----|-----|-----------------------------|-------------|-----------------|-------------|--------------|-------|
|                         |                         | DC  | DCONMS | LU  | LPR |                             |             |                 |             |              |       |
| 1 INSERT PER CARTRIDGE  |                         |   |        |     |     |                             |             |                 |             |              |       |
| 184194400               | DHC 004140-8D           | 41  | 40     | 340 | 375 | CWC 041045-I / CWC 000041-O | WCKX 06T308 | P0350903        | XT15        | MDP 3510     | ○     |
| 184194500               | DHC 004240-8D           | 42  | 40     | 340 | 375 | CWC 041045-I / CWC 000042-O | WCKX 06T308 | P0350903        | XT15        | MDP 3510     | ○     |
| 184194600               | DHC 004340-8D           | 43  | 40     | 340 | 375 | CWC 041045-I / CWC 000043-O | WCKX 06T308 | P0350903        | XT15        | MDP 3510     | ○     |
| 184194700               | DHC 004440-8D           | 44  | 40     | 340 | 375 | CWC 041045-I / CWC 000044-O | WCKX 06T308 | P0350903        | XT15        | MDP 3510     | ○     |
| 184194800               | DHC 004540-8D           | 45  | 40     | 340 | 375 | CWC 041045-I / CWC 000045-O | WCKX 06T308 | P0350903        | XT15        | MDP 3510     | ○     |
| 184194900               | DHC 004640-8D           | 46  | 40     | 380 | 415 | CWC 046050-I / CWC 000046-O | WCKX 06T308 | P0350903        | XT15        | MDP 3510     | ○     |
| 184195000               | DHC 004740-8D           | 47  | 40     | 380 | 415 | CWC 046050-I / CWC 000047-O | WCKX 06T308 | P0350903        | XT15        | MDP 3510     | ○     |
| 184195100               | DHC 004840-8D           | 48  | 40     | 380 | 415 | CWC 046050-I / CWC 000048-O | WCKX 06T308 | P0350903        | XT15        | MDP 3510     | ○     |
| 184195200               | DHC 004940-8D           | 49  | 40     | 380 | 415 | CWC 046050-I / CWC 000049-O | WCKX 06T308 | P0350903        | XT15        | MDP 3510     | ○     |
| 184195300               | DHC 005040-8D           | 50  | 40     | 380 | 415 | CWC 046050-I / CWC 000050-O | WCKX 06T308 | P0350903        | XT15        | MDP 3510     | ○     |
| 184195400               | DHC 005140-8D           | 51  | 40     | 420 | 455 | CWC 051055-I / CWC 000051-O | WCKX 080408 | P0401101        | XT15        | MDP 3812     | ○     |
| 184195500               | DHC 005240-8D           | 52  | 40     | 420 | 455 | CWC 051055-I / CWC 000052-O | WCKX 080408 | P0401101        | XT15        | MDP 3812     | ○     |
| 184195600               | DHC 005340-8D           | 53  | 40     | 420 | 455 | CWC 051055-I / CWC 000053-O | WCKX 080408 | P0401101        | XT15        | MDP 3812     | ○     |
| 184195700               | DHC 005440-8D           | 54  | 40     | 420 | 455 | CWC 051055-I / CWC 000054-O | WCKX 080408 | P0401101        | XT15        | MDP 3812     | ○     |
| 184195800               | DHC 005540-8D           | 55  | 40     | 420 | 455 | CWC 051055-I / CWC 000055-O | WCKX 080408 | P0401101        | XT15        | MDP 3812     | ○     |
| 184195900               | DHC 005640-8D           | 56  | 40     | 460 | 495 | CWC 056059-I / CWC 000056-O | WCKX 080408 | P0401101        | XT15        | MDP 3812     | ○     |
| 184196000               | DHC 005740-8D           | 57  | 40     | 460 | 495 | CWC 056059-I / CWC 000057-O | WCKX 080408 | P0401101        | XT15        | MDP 3812     | ○     |
| 184196100               | DHC 005840-8D           | 58  | 40     | 460 | 495 | CWC 056059-I / CWC 000058-O | WCKX 080408 | P0401101        | XT15        | MDP 3812     | ○     |
| 184196200               | DHC 005940-8D           | 59  | 40     | 460 | 495 | CWC 056059-I / CWC 000059-O | WCKX 080408 | P0401101        | XT15        | MDP 3812     | ○     |
| 2 INSERTS PER CARTRIDGE |                         |   |        |     |     |                             |             |                 |             |              |       |
| 184066000               | DHC 606540-8D           | 60-65                                       | 40     | 520 | 555 | MDC 060065-I/O              | WCKX 050308 | P0300701        | XT08        | MDP 3812     | ○     |
| 184066100               | DHC 657040-8D           | 65-70                                       | 40     | 560 | 595 | MDC 065070-I/O              | WCKX 050308 | P0300701        | XT08        | MDP 3812     | ○     |
| 184066200               | DHC 707540-8D           | 70-75                                       | 40     | 600 | 635 | MDC 070075-I/O              | WCKX 050308 | P0300701        | XT08        | MDP 3812     | ○     |
| 184066300               | DHC 758040-8D           | 75-80                                       | 40     | 640 | 675 | MDC 075080-I/O              | WCKX 06T308 | P0350903        | XT15        | MDP 4516     | ○     |

⊗ Stock item | Produto de stock | Itens de stock      ○ Available under request | Disponível sobre consulta | Disponible bajo consulta

Note: This type of drills are supplied without pilot drills. Please order them separately.

Please see Page B - 449 for setting pilot drill.





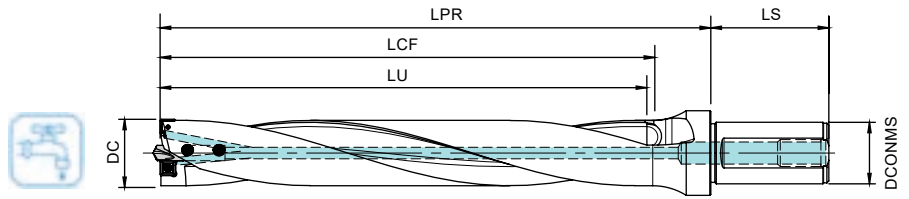





















Pilot Drill  
mounting procedure







| DCONMS | LS | BP / SP  |
|--------|----|----------|
| 25     | 56 | PT - 1/8 |
| 32     | 60 | PT - 1/4 |

\*Order separately

| Order code<br>Código | Reference<br>Referência<br>Referencia | Dimensions   Dimensões   Dimensiones (mm) |        |     |     |     | Insert      | Insert Screw<br> | Torx key<br> | Pilot drill*<br> | Stock<br> |
|----------------------|---------------------------------------|---|--------|-----|-----|-----|-------------|--|--|--|---|
|                      |                                       | DC  | DCONMS | LU  | LCF | LPR |             |  |  |  |   |
| 184154300            | TFD 18025-6D                          | 18,0                                      | 25     | 108 | 112 | 142 | SPKX 050204 | P0200500   | XT06   | MDP 2006   |          |
| 184154400            | TFD 18525-6D                          | 18,5                                      | 25     | 111 | 115 | 145 | SPKX 050204 | P0200500   | XT06   | MDP 2006   |          |
| 184154500            | TFD 19025-6D                          | 19,0                                      | 25     | 114 | 118 | 148 | SPKX 050204 | P0200500   | XT06   | MDP 2006   |          |
| 184154600            | TFD 19525-6D                          | 19,5                                      | 25     | 117 | 121 | 151 | SPKX 050204 | P0200500   | XT06   | MDP 2006   |          |
| 184154700            | TFD 20025-6D                          | 20,0                                      | 25     | 120 | 124 | 154 | SP.X 060204 | P0220500   | XT07   | MDP 2006   |          |
| 184154800            | TFD 20525-6D                          | 20,5                                      | 25     | 123 | 127 | 157 | SP.X 060204 | P0220500   | XT07   | MDP 2006   |          |
| 184154900            | TFD 21025-6D                          | 21,0                                      | 25     | 126 | 130 | 160 | SP.X 060204 | P0220500   | XT07   | MDP 2006   |          |
| 184155000            | TFD 21525-6D                          | 21,5                                      | 25     | 129 | 133 | 163 | SP.X 060204 | P0220500   | XT07   | MDP 2006   |          |
| 184155100            | TFD 22025-6D                          | 22,0                                      | 25     | 132 | 136 | 166 | SP.X 060204 | P0220500   | XT07   | MDP 2006   |          |
| 184155200            | TFD 22525-6D                          | 22,5                                      | 25     | 135 | 139 | 169 | SP.X 060204 | P0220500   | XT07   | MDP 2006   |          |
| 184155300            | TFD 23025-6D                          | 23,0                                      | 25     | 138 | 142 | 172 | SP.X 060204 | P0220500   | XT07   | MDP 2006   |          |
| 184155400            | TFD 23525-6D                          | 23,5                                      | 25     | 141 | 145 | 175 | SP.X 060204 | P0220500   | XT07   | MDP 2006   |          |
| 184155500            | TFD 24025-6D                          | 24,0                                      | 25     | 144 | 148 | 178 | SP.X 060204 | P0220500   | XT07   | MDP 2006   |          |
| 184155600            | TFD 24525-6D                          | 24,5                                      | 25     | 147 | 151 | 181 | SP.X 060204 | P0220500   | XT07   | MDP 2006   |          |
| 184155700            | TFD 25025-6D                          | 25,0                                      | 25     | 150 | 154 | 184 | SP.X 060204 | P0220500   | XT07   | MDP 2006   |          |
| 184155800            | TFD 25532-6D                          | 25,5                                      | 32     | 153 | 157 | 192 | SPKX 07T308 | P0250704   | XT08   | MDP 2508   |          |
| 184155900            | TFD 26032-6D                          | 26,0                                      | 32     | 156 | 160 | 195 | SPKX 07T308 | P0250704   | XT08   | MDP 2508   |          |
| 184156000            | TFD 26532-6D                          | 26,5                                      | 32     | 159 | 163 | 198 | SPKX 07T308 | P0250704   | XT08   | MDP 2508   |          |
| 184156100            | TFD 27032-6D                          | 27,0                                      | 32     | 162 | 166 | 201 | SPKX 07T308 | P0250704   | XT08   | MDP 2508   |          |
| 184156200            | TFD 27532-6D                          | 27,5                                      | 32     | 165 | 169 | 204 | SPKX 07T308 | P0250704   | XT08   | MDP 2508   |          |
| 184156300            | TFD 28032-6D                          | 28,0                                      | 32     | 168 | 172 | 207 | SPKX 07T308 | P0250704   | XT08   | MDP 2508   |          |
| 184156400            | TFD 28532-6D                          | 28,5                                      | 32     | 171 | 175 | 210 | SPKX 07T308 | P0250704   | XT08   | MDP 2508   |          |
| 184156500            | TFD 29032-6D                          | 29,0                                      | 32     | 174 | 178 | 213 | SPKX 07T308 | P0250704   | XT08   | MDP 2508   |          |
| 184156600            | TFD 29532-6D                          | 29,5                                      | 32     | 177 | 181 | 216 | SPKX 07T308 | P0250704   | XT08   | MDP 2508   |          |
| 184156700            | TFD 30032-6D                          | 30,0                                      | 32     | 180 | 184 | 219 | SPKX 07T308 | P0250704   | XT08   | MDP 2508   |          |

 Stock item | Produto de stock | Itens de stock     Available under request | Disponível sobre consulta | Disponible bajo consulta

Note: This type of drills are supplied without pilot drills. Please order them separately.

Please see Page B - 449 for setting pilot drill.



Pilot Drill  
mounting procedure

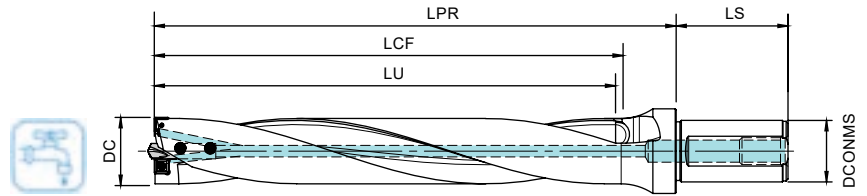



| DCONMS | LS | BP / SP  |
|--------|----|----------|
| 25     | 56 | PT - 1/8 |
| 32     | 60 | PT - 1/4 |

\*Order separately

| Order code<br>Código | Reference<br>Referência<br>Referencia | Dimensions   Dimensões   Dimensiones (mm) |        |     |     |     | Insert       | Insert Screw<br> | Torx key<br> | Pilot drill*<br> | Stock |
|----------------------|---------------------------------------|---|--------|-----|-----|-----|--------------|--|--|--|-------|
|                      |                                       | DC  | DCONMS | LU  | LCF | LPR |              |  |  |  |       |
| 184151800            | TFD 18025-8D                          | 18,0                                      | 25     | 144 | 149 | 179 | SPKX 050204  | P0200500   | XT06   | MDP 2006   | ☺     |
| 184151900            | TFD 18525-8D                          | 18,5                                      | 25     | 148 | 153 | 183 | SPKX 050204  | P0200500   | XT06   | MDP 2006   | ☺     |
| 184152000            | TFD 19025-8D                          | 19,0                                      | 25     | 152 | 157 | 187 | SPKX 050204  | P0200500   | XT06   | MDP 2006   | ○     |
| 184152100            | TFD 19525-8D                          | 19,5                                      | 25     | 156 | 161 | 191 | SPKX 050204  | P0200500   | XT06   | MDP 2006   | ○     |
| 184152200            | TFD 20025-8D                          | 20,0                                      | 25     | 160 | 165 | 195 | SP..X 060204 | P0220500   | XT07   | MDP 2006   | ☺     |
| 184152300            | TFD 20525-8D                          | 20,5                                      | 25     | 164 | 169 | 199 | SP..X 060204 | P0220500   | XT07   | MDP 2006   | ○     |
| 184152400            | TFD 21025-8D                          | 21,0                                      | 25     | 168 | 173 | 203 | SP..X 060204 | P0220500   | XT07   | MDP 2006   | ☺     |
| 184152500            | TFD 21525-8D                          | 21,5                                      | 25     | 172 | 177 | 207 | SP..X 060204 | P0220500   | XT07   | MDP 2006   | ○     |
| 184151200            | TFD 22025-8D                          | 22,0                                      | 25     | 176 | 181 | 211 | SP..X 060204 | P0220500   | XT07   | MDP 2006   | ○     |
| 184152700            | TFD 22525-8D                          | 22,5                                      | 25     | 180 | 185 | 215 | SP..X 060204 | P0220500   | XT07   | MDP 2006   | ○     |
| 184152800            | TFD 23025-8D                          | 23,0                                      | 25     | 184 | 189 | 219 | SP..X 060204 | P0220500   | XT07   | MDP 2006   | ○     |
| 184152900            | TFD 23525-8D                          | 23,5                                      | 25     | 188 | 193 | 223 | SP..X 060204 | P0220500   | XT07   | MDP 2006   | ○     |
| 184153000            | TFD 24025-8D                          | 24,0                                      | 25     | 192 | 197 | 227 | SP..X 060204 | P0220500   | XT07   | MDP 2006   | ☺     |
| 184153100            | TFD 24525-8D                          | 24,5                                      | 25     | 196 | 201 | 231 | SP..X 060204 | P0220500   | XT07   | MDP 2006   | ○     |
| 184151300            | TFD 25025-8D                          | 25,0                                      | 25     | 200 | 205 | 235 | SP..X 060204 | P0220500   | XT07   | MDP 2006   | ☺     |
| 184153300            | TFD 25532-8D                          | 25,5                                      | 32     | 204 | 209 | 244 | SPKX 07T308  | P0250704   | XT08   | MDP 2508   | ○     |
| 184153400            | TFD 26032-8D                          | 26,0                                      | 32     | 208 | 213 | 248 | SPKX 07T308  | P0250704   | XT08   | MDP 2508   | ☺     |
| 184153500            | TFD 26532-8D                          | 26,5                                      | 32     | 212 | 217 | 252 | SPKX 07T308  | P0250704   | XT08   | MDP 2508   | ○     |
| 184153600            | TFD 27032-8D                          | 27,0                                      | 32     | 216 | 221 | 256 | SPKX 07T308  | P0250704   | XT08   | MDP 2508   | ○     |
| 184153700            | TFD 27532-8D                          | 27,5                                      | 32     | 220 | 225 | 260 | SPKX 07T308  | P0250704   | XT08   | MDP 2508   | ○     |
| 184153800            | TFD 28032-8D                          | 28,0                                      | 32     | 224 | 229 | 264 | SPKX 07T308  | P0250704   | XT08   | MDP 2508   | ○     |
| 184153900            | TFD 28532-8D                          | 28,5                                      | 32     | 228 | 233 | 268 | SPKX 07T308  | P0250704   | XT08   | MDP 2508   | ○     |
| 184154000            | TFD 29032-8D                          | 29,0                                      | 32     | 232 | 237 | 272 | SPKX 07T308  | P0250704   | XT08   | MDP 2508   | ☺     |
| 184154100            | TFD 29532-8D                          | 29,5                                      | 32     | 236 | 241 | 276 | SPKX 07T308  | P0250704   | XT08   | MDP 2508   | ○     |
| 184154200            | TFD 30032-8D                          | 30,0                                      | 32     | 240 | 245 | 280 | SPKX 07T308  | P0250704   | XT08   | MDP 2508   | ☺     |

☺ Stock item | Produto de stock | Itens de stock      ○ Available under request | Disponível sobre consulta | Disponible bajo consulta

Note: This type of drills are supplied without pilot drills. Please order them separately.

Please see Page B - 449 for setting pilot drill.

Pilot Drill  
mounting procedure



# VORTEX

## DRILLS



Vortex drills offer the best solution for drilling extensive dimensions in both diameter and length. The drilling depth can be adjusted using extensions and reducers, while the diameter adjustment is accomplished by shortening the outer cartridge.

As brocas Vortex oferecem a melhor solução para perfurar dimensões extensas tanto em diâmetro quanto em comprimento. A profundidade de perfuração pode ser ajustada usando extensões e redutores, enquanto o ajuste de diâmetro é realizado encurtando o cartucho externo.

Las brocas Vortex ofrecen la mejor solución para perforar dimensiones extensas tanto en diámetro como en longitud. La profundidad de perforación puede ajustarse utilizando extensiones y reductores, mientras que el ajuste de diámetro se logra acortando el cartucho exterior.

## MDO > page 414

- > From DC 45,0mm to 180,0mm  
De DC 45,0mm a 180,0mm | Desde DC 45,0mm hasta 180,0mm
- > 2 or 3 WCKX inserts per cartridge  
2 ou 3 pastilhas WCKX por cartucho | 2 o 3 plaquitas WCKX por cartucho
- > Pilot drill  
Broca piloto | Taladro piloto



## MDS > page 416

- > Shank  
Encabadouro | Caña

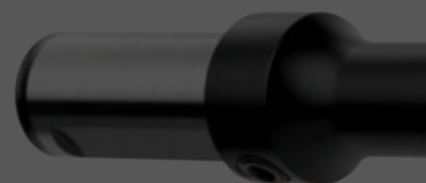







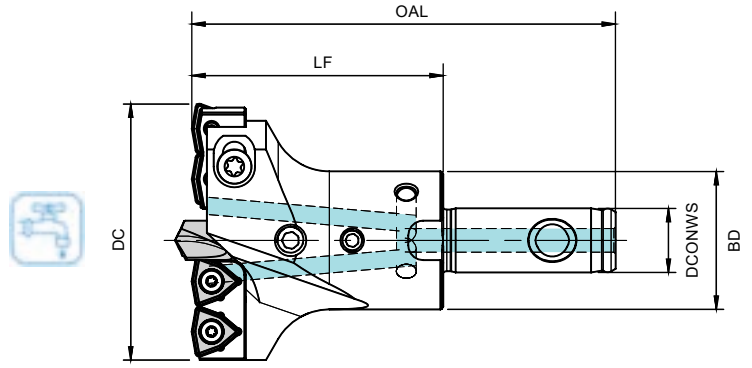
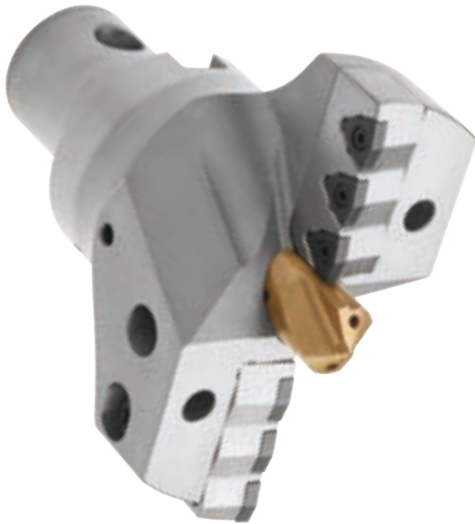







## MDE > page 417



- > Extension  
Extensor | Extensor





\*Order separately

| Order code<br>Código    | Reference<br>Referência<br>Referencia | Dimensions   Dimensões   Dimensiones (mm) |        |    |     |    | Cartridge      | Insert      | Insert Screw<br> | Torx key<br> | Pilot drill*<br> | Stock   |
|-------------------------|---------------------------------------|---|--------|----|-----|----|----------------|-------------|--|--|--|---|
|                         |                                       | DC  | DCONWS | LF | OAL | BD |                |             |  |  |  |   |
| 2 INSERTS PER CARTRIDGE |                                       |   |        |    |     |    |                |             |  |  |  |   |
| 184031000               | MDO 04505013                          | 45-50                                     | 13     | 50 | 85  | 28 | MDC 045050-I/O | WCKX 030204 | P0220500   | XT07   | MDP 3510   |  |
| 184031100               | MDO 05005513                          | 50-55                                     | 13     | 50 | 85  | 28 | MDC 050055-I/O | WCKX 030204 | P0220500   | XT07   | MDP 3510   |  |
| 184031200               | MDO 05506016                          | 55-60                                     | 16     | 60 | 100 | 32 | MDC 055060-I/O | WCKX 040204 | P0250503   | XT08   | MDP 3812   |  |
| 184031300               | MDO 06006516                          | 60-65                                     | 16     | 60 | 100 | 32 | MDC 060065-I/O | WCKX 050308 | P0300701   | XT08   | MDP 3812   |  |
| 184031500               | MDO 06507016                          | 65-70                                     | 16     | 60 | 100 | 32 | MDC 065070-I/O | WCKX 050308 | P0300701   | XT08   | MDP 3812   |  |
| 184032400               | MDO 07007522                          | 70-75                                     | 22     | 70 | 115 | 40 | MDC 070075-I/O | WCKX 050308 | P0300701   | XT08   | MDP 3812   |  |
| 184032500               | MDO 07508022                          | 75-80                                     | 22     | 70 | 115 | 40 | MDC 075080-I/O | WCKX 06T308 | P0350903   | XT15   | MDP 4516   |  |
| 184032600               | MDO 08008522                          | 80-85                                     | 22     | 70 | 115 | 40 | MDC 080085-I/O | WCKX 06T308 | P0350903   | XT15   | MDP 4516   |  |
| 184032700               | MDO 08509027                          | 85-90                                     | 27     | 70 | 120 | 48 | MDC 085090-I/O | WCKX 06T308 | P0350903   | XT15   | MDP 4516   |  |
| 184032800               | MDO 09009527                          | 90-95                                     | 27     | 70 | 120 | 48 | MDC 090095-I/O | WCKX 06T308 | P0350903   | XT15   | MDP 4516   |  |
| 184032900               | MDO 09510027                          | 95-100                                    | 27     | 70 | 120 | 48 | MDC 095100-I/O | WCKX 06T308 | P0350903   | XT15   | MDP 4516   |  |

 Stock item | Produto de stock | Itens de stock     Available under request | Disponível sobre consulta | Disponible bajo consulta

Drills with larger diameter available under request with a minimum order quantity.

**Note:** This type of drills are supplied without pilot drills. Please order them separately.



Please see Page B - 450 for setting pilot drill.

Pilot Drill  
mounting procedure

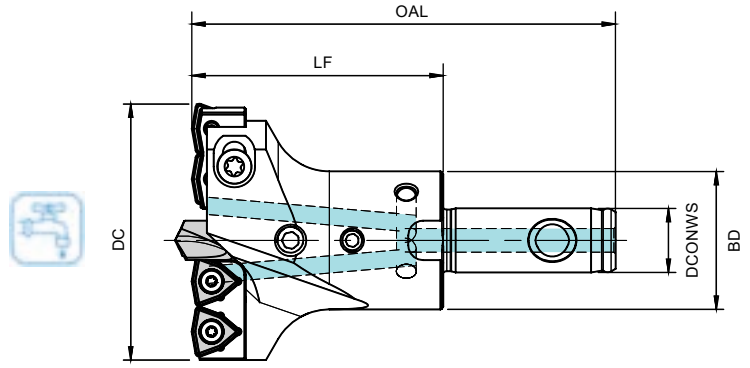



\*Order separately

| Order code<br>Código    | Reference<br>Referência<br>Referencia | Dimensions   Dimensões   Dimensiones (mm) |        |     |     |    | Cartridge      | Insert      | Insert Screw<br> | Torx key<br> | Pilot drill*<br> | Stock |
|-------------------------|---------------------------------------|---|--------|-----|-----|----|----------------|-------------|--|--|--|-------|
|                         |                                       | DC  | DCONWS | LF  | OAL | BD |                |             |  |  |  |       |
| 3 INSERTS PER CARTRIDGE |                                       |   |        |     |     |    |                |             |  |  |  |       |
| 184033000               | MDO 10010532                          | 100-105                                   | 32     | 80  | 130 | 58 | MDC 100105-I/O | WCKX 050308 | P0300701   | XT08   | MDP 4520   | ☉     |
| 184066400               | MDO 10511032                          | 105-110                                   | 32     | 80  | 130 | 58 | MDC 105110-I/O | WCKX 06T308 | P0350903   | XT15   | MDP 4520   | ☉     |
| 184066500               | MDO 11011532                          | 110-115                                   | 32     | 80  | 130 | 58 | MDC 110115-I/O | WCKX 06T308 | P0350903   | XT15   | MDP 4520   | ☉     |
| 184066600               | MDO 11512040                          | 115-120                                   | 40     | 90  | 145 | 70 | MDC 115120-I/O | WCKX 06T308 | P0350903   | XT15   | MDP 4520   | ☉     |
| 184066700               | MDO 12012540                          | 120-125                                   | 40     | 90  | 145 | 70 | MDC 120125-I/O | WCKX 06T308 | P0350903   | XT15   | MDP 5625   | ☉     |
| 184066800               | MDO 12513040                          | 125-130                                   | 40     | 90  | 145 | 70 | MDC 125130-I/O | WCKX 06T308 | P0350903   | XT15   | MDP 5625   | ☉     |
| 184066900               | MDO 13013540                          | 130-135                                   | 40     | 90  | 145 | 70 | MDC 130135-I/O | WCKX 06T308 | P0350903   | XT15   | MDP 5625   | ☉     |
| 184067000               | MDO 13514040                          | 135-140                                   | 40     | 90  | 145 | 70 | MDC 135140-I/O | WCKX 06T308 | P0350903   | XT15   | MDP 5625   | ☉     |
| 184067100               | MDO 14015050                          | 140-150                                   | 50     | 100 | 160 | 80 | MDC 140150-I/O | WCKX 080408 | P0401101   | XT15   | MDP 5625   | ☉     |
| 184067200               | MDO 15016050                          | 150-160                                   | 50     | 100 | 160 | 80 | MDC 150160-I/O | WCKX 080408 | P0401101   | XT15   | MDP 5625   | ☉     |
| 184067300               | MDO 16017050                          | 160-170                                   | 50     | 100 | 160 | 80 | MDC 160170-I/O | WCKX 080408 | P0401101   | XT15   | MDP 6830   | ☉     |
| 184067400               | MDO 17018050                          | 170-180                                   | 50     | 100 | 160 | 80 | MDC 170180-I/O | WCKX 080408 | P0401101   | XT15   | MDP 6830   | ☉     |

☉ Stock item | Produto de stock | Itens de stock      ○ Available under request | Disponível sobre consulta | Disponible bajo consulta

Drills with larger diameter available under request with a minimum order quantity.

**Note:** This type of drills are supplied without pilot drills. Please order them separately.

Please see Page B - 450 for setting pilot drill.

Pilot Drill  
mounting procedure



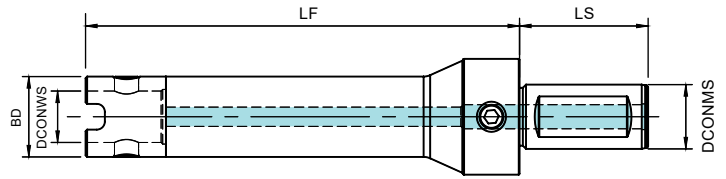

New version / Standard version\*

| DCONWS | LS       | BP / SP  |
|--------|----------|----------|
| 32     | 70       | PT - 1/4 |
| 40     | 80       | PT - 1/4 |
| 50     | 80 / 100 | PT - 1/4 |

\*Order separately

| Order code<br>Código | Reference<br>Referência<br>Referencia | Dimensions   Dimensões   Dimensiones (mm) |        |    |     | Drive Ring* | Stock |
|----------------------|---------------------------------------|---|--------|----|-----|-------------|-------|
|                      |                                       | DCONMS                                    | DCONWS | BD | LF  |             |       |
| 184121900            | MDS 32115130                          | 32  | 13     | 28 | 115 | MDR 1028    | ☉     |
| 184253700            | MDS 32200130                          | 32  | 13     | 28 | 200 | MDR 1028    | ☉     |
| 184255400            | MDS 32300130                          | 32  | 13     | 28 | 300 | MDR 1028    | ☉     |
| 184122100            | MDS 40125160                          | 40  | 16     | 32 | 125 | MDR 1032    | ☉     |
| 184253800            | MDS 40200160                          | 40  | 16     | 32 | 200 | MDR 1032    | ☉     |
| 184255500            | MDS 40300160                          | 40  | 16     | 32 | 300 | MDR 1032    | ☉     |
| 184122300            | MDS 40148220                          | 40  | 22     | 40 | 148 | MDR 1240    | ☉     |
| 184122400            | MDS 40200220                          | 40  | 22     | 40 | 200 | MDR 1240    | ☉     |
| 184122500            | MDS 40300220                          | 40  | 22     | 40 | 300 | MDR 1240    | ☉     |
| 184122600            | MDS 40168270                          | 40  | 27     | 48 | 168 | MDR 1248    | ☉     |
| 184122700            | MDS 40300270                          | 40  | 27     | 48 | 300 | MDR 1248    | ☉     |
| 184122800            | MDS 40186320                          | 40  | 32     | 58 | 186 | MDR 1458    | ☉     |
| 184122900            | MDS 40300320                          | 40  | 32     | 58 | 300 | MDR 1458    | ☉     |
| 184123000            | MDS 50186400                          | 50  | 40     | 70 | 186 | MDR 1470    | ☉     |
| 184123100            | MDS 50300400                          | 50  | 40     | 70 | 300 | MDR 1470    | ☉     |
| 184123200            | MDS 50184500                          | 50  | 50     | 80 | 184 | MDR 1680    | ☉     |
| 184123300            | MDS 50300500                          | 50  | 50     | 80 | 300 | MDR 1680    | ☉     |

☉ Stock item | Produto de stock | Itens de stock    ○ Available under request | Disponível sobre consulta | Disponible bajo consulta

Note: This type of shank are supplied without drive ring. Please order them separately.

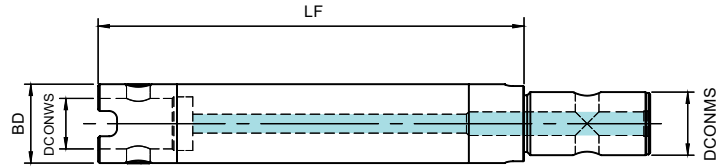

\*Order separately

| Order code<br>Código | Reference<br>Referência<br>Referencia | Dimensions   Dimensões   Dimensiones (mm) |        |    |     | Drive Ring* | Stock |
|----------------------|---------------------------------------|---|--------|----|-----|-------------|-------|
|                      |                                       | DCONMS                                    | DCONWS | BD | LF  |             |       |
| 184023500            | MDE 13115280                          | 13  | 13     | 28 | 115 | MDR 1028    | ☺     |
| 184023600            | MDE 13150280                          | 13  | 13     | 28 | 150 | MDR 1028    | ☺     |
| 184023700            | MDE 13200280                          | 13  | 13     | 28 | 200 | MDR 1028    | ☺     |
| 184021800            | MDE 13300280                          | 13  | 13     | 28 | 300 | MDR 1028    | ☺     |
| 184023800            | MDE 16115320                          | 16  | 16     | 32 | 115 | MDR 1032    | ☺     |
| 184021900            | MDE 16200320                          | 16  | 16     | 32 | 200 | MDR 1032    | ☺     |
| 184023900            | MDE 16300320                          | 16  | 16     | 32 | 300 | MDR 1032    | ☺     |
| 184024000            | MDE 22113400                          | 22  | 22     | 40 | 113 | MDR 1240    | ☺     |
| 184024100            | MDE 22200400                          | 22  | 22     | 40 | 200 | MDR 1240    | ☺     |
| 184024200            | MDE 22300400                          | 22  | 22     | 40 | 300 | MDR 1240    | ☺     |
| 184024300            | MDE 27113480                          | 27  | 27     | 48 | 113 | MDR 1248    | ☺     |
| 184024400            | MDE 27200480                          | 27  | 27     | 48 | 200 | MDR 1248    | ☺     |
| 184024500            | MDE 27300480                          | 27  | 27     | 48 | 300 | MDR 1248    | ☺     |
| 184024600            | MDE 32186580                          | 32  | 32     | 58 | 186 | MDR 1458    | ☺     |
| 184024700            | MDE 32300580                          | 32  | 32     | 58 | 300 | MDR 1458    | ☺     |
| 184024800            | MDE 40186700                          | 40  | 40     | 70 | 186 | MDR 1470    | ☺     |
| 184024900            | MDE 40300700                          | 40  | 40     | 70 | 300 | MDR 1470    | ☺     |
| 184025000            | MDE 40500700                          | 40  | 40     | 70 | 500 | MDR 1470    | ☺     |
| 184025100            | MDE 50204800                          | 50  | 50     | 80 | 204 | MDR 1680    | ☺     |
| 184025200            | MDE 50300800                          | 50  | 50     | 80 | 300 | MDR 1680    | ☺     |
| 184025300            | MDE 50500800                          | 50  | 50     | 80 | 500 | MDR 1680    | ☺     |

☺ Stock item | Produto de stock | Itens de stock      ○ Available under request | Disponível sobre consulta | Disponible bajo consulta

Note: This type of shank are supplied without drive ring. Please order them separately.

# TREPANNING

## DRILLS



Trepanning drills are ideal for drilling larger hole diameters in situations where machine power is restricted, as they consume less power compared to conventional drilling methods. Instead of machining the entire hole, only a peripheral ring is created. Consequently, this method is for through-hole applications.

As brocas de furação são ideais para perfurar diâmetros grandes em situações em que a potência da máquina é restrita, pois consomem menos energia em comparação com os métodos de perfuração convencionais. Na vez de maquinar todo o furo, é criado apenas um anel periférico. Consequentemente, este método é indicado para aplicações de furos passantes.

Las brocas de trepanación son ideales para perforar diámetros grandes en situaciones donde la potencia de la máquina está restringida, ya que consumen menos energía en comparación con los métodos de perforación convencionales. En lugar de mecanizar todo el agujero, solo se crea un anillo periférico. En consecuencia, este método es para aplicaciones de agujeros pasantes.

## **PND** > page 420

> From DC 40,0mm to 110,0mm

De DC 40,0mm a 110,0mm | Desde DC 40,0mm hasta 110,0mm



> Available in 2D

Disponível em 2D | Disponible en 2D

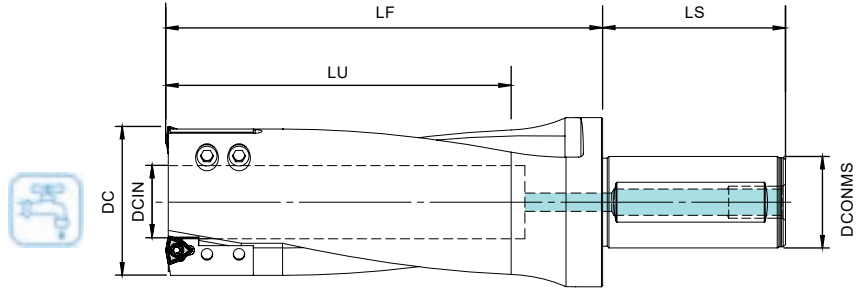



| DCONMS | LS  | BP / SP  |
|--------|-----|----------|
| 32     | 70  | PT - 1/4 |
| 40     | 80  | PT - 1/4 |
| 50     | 100 | PT - 1/4 |

| Order code<br>Código | Reference<br>Referência<br>Referencia | Dimensions   Dimensões   Dimensiones (mm) |      |        |     |     | Cartridge      | Insert      | Insert Screw<br> | Torx key<br> | Stock |
|----------------------|---------------------------------------|---|------|--------|-----|-----|----------------|-------------|--|--|-------|
|                      |                                       | DC  | DCIN | DCONMS | LU  | LF  |                |             |  |  |       |
| 184067500            | PND 04032-2D                          | 40,0                                      | 10,0 | 32     | 100 | 140 | PNC 040055-I/O | WCKX 050308 | P0300701   | XT08   | ○     |
| 184067600            | PND 04540-2D                          | 45,0                                      | 15,0 | 40     | 100 | 130 | PNC 040055-I/O | WCKX 050308 | P0300701   | XT08   | ○     |
| 184067700            | PND 05040-2D                          | 50,0                                      | 21,0 | 40     | 120 | 150 | PNC 040055-I/O | WCKX 050308 | P0300701   | XT08   | ○     |
| 184067800            | PND 05540-2D                          | 55,0                                      | 26,0 | 40     | 120 | 150 | PNC 040055-I/O | WCKX 050308 | P0300701   | XT08   | ○     |
| 184067900            | PND 06040-2D                          | 60,0                                      | 24,5 | 40     | 150 | 190 | PNC 060110-I/O | WCKX 06T308 | P0350903   | XT15   | ○     |
| 184068000            | PND 06540-2D                          | 65,0                                      | 30,5 | 40     | 150 | 190 | PNC 060110-I/O | WCKX 06T308 | P0350903   | XT15   | ○     |
| 184068100            | PND 07040-2D                          | 70,0                                      | 35,5 | 40     | 170 | 210 | PNC 060110-I/O | WCKX 06T308 | P0350903   | XT15   | ○     |
| 184068200            | PND 07540-2D                          | 75,0                                      | 40,5 | 40     | 170 | 210 | PNC 060110-I/O | WCKX 06T308 | P0350903   | XT15   | ○     |
| 184068300            | PND 08040-2D                          | 80,0                                      | 45,5 | 40     | 190 | 230 | PNC 060110-I/O | WCKX 06T308 | P0350903   | XT15   | ○     |
| 184068400            | PND 08550-2D                          | 85,0                                      | 50,5 | 50     | 190 | 230 | PNC 060110-I/O | WCKX 06T308 | P0350903   | XT15   | ○     |
| 184068500            | PND 09050-2D                          | 90,0                                      | 55,0 | 50     | 210 | 250 | PNC 060110-I/O | WCKX 06T308 | P0350903   | XT15   | ○     |
| 184068600            | PND 09550-2D                          | 95,0                                      | 60,0 | 50     | 210 | 250 | PNC 060110-I/O | WCKX 06T308 | P0350903   | XT15   | ○     |
| 184068700            | PND 10050-2D                          | 100,0                                     | 66,0 | 50     | 250 | 290 | PNC 060110-I/O | WCKX 06T308 | P0350903   | XT15   | ○     |
| 184068800            | PND 11050-2D                          | 110,0                                     | 76,0 | 50     | 250 | 290 | PNC 060110-I/O | WCKX 06T308 | P0350903   | XT15   | ○     |

⊗ Stock item | Produto de stock | Itens de stock      ○ Available under request | Disponível sobre consulta | Disponible bajo consulta

# CUTTING PARAMETERS AND ADJUSTMENTS

Parâmetros de corte e ajustes | Condiciones de corte y ajustes

## RECOMMENDED SPEEDS AND FEEDS

| ISO | Material Group<br>Grupo Materiais<br>Grupo Materiales | DC (mm) | Fn (mm/r) | Vc (m/min) |
|-----|---|---------|-----------|------------|
| P   | Unalloyed steel (-0,25%)                              | 60-110  | 0,07-0,20 | 130-345    |
|     | Low-alloy steel (0,25%-)                              | 60-110  | 0,10-0,20 | 100-210    |
|     | Low-alloy steel                                       | 60-110  | 0,10-0,20 | 90-200     |
|     | Steel casting   | 60-110  | 0,06-0,18 | 120-280    |
| M   | Stainless steel                                       | 60-110  | 0,10-0,20 | 100-240    |
| K   | Grey cast iron  | 60-110  | 0,14-0,26 | 105-280    |
|     | Cast iron with nodular cast                           | 60-110  | 0,14-0,20 | 110-195    |
| N   | Aluminium forging alloys                              | 60-110  | 0,12-0,22 | 250-400    |
|     | Copper and copper alloys                              | 60-110  | 0,12-0,22 | 180-350    |

## POWER REQUIREMENTS

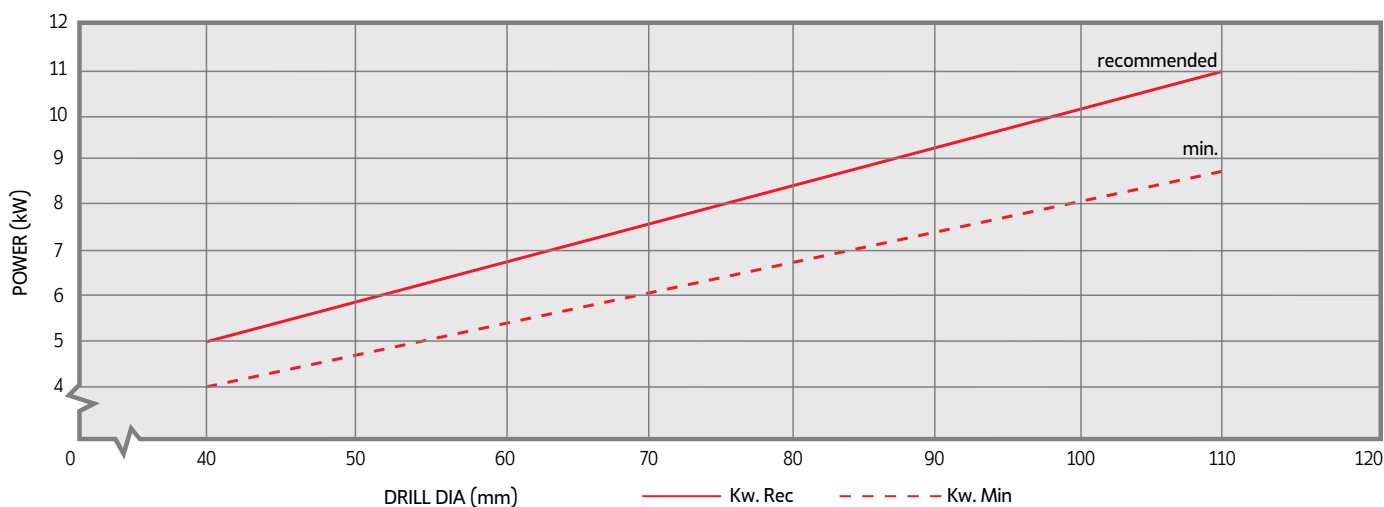

• The cutting fluid quantity is measured at the cutting edge of the drill

## COOLANT APPLICATION CHART

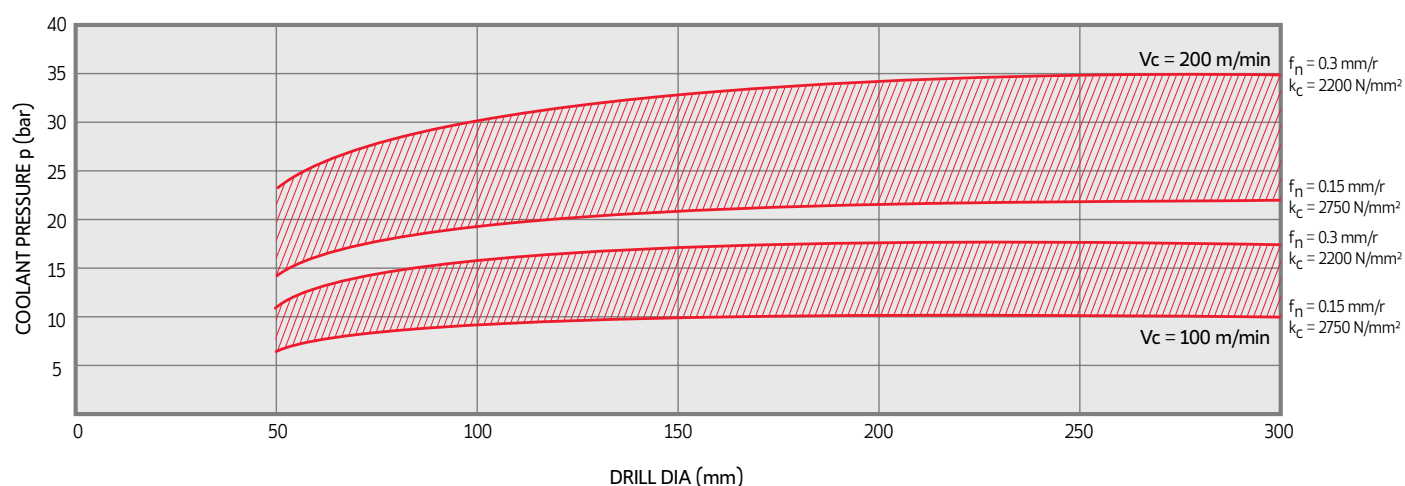

# INSERTS



Drilling inserts, specialized for various applications and materials, optimize cutting processes by providing precise geometries and coatings, resulting in improved chip evacuation, surface finish, and overall tool performance.

As pastilhas de furação, especializadas para diversas aplicações e materiais, otimizam os processos de corte fornecendo geometrias e revestimentos precisos, resultando numa melhor evacuação de aparas, acabamento de superfície e desempenho geral da ferramenta.

Las plaquitas de furación, especializadas para diversas aplicaciones y materiales, optimizan los procesos de corte al proporcionar geometrías y recubrimientos precisos, lo que resulta en una mejor evacuación de rompevirutas, acabado superficial y rendimiento general de la herramienta.

## SP...X > page 426

- > From sizes 05 to 14

De tamanhos de 05 a 14 | De tamaños de 05 a 14

- > Available in grades PH6920, PH6930, PHC930, PHL930 and PH0910

Disponível nos graus PH6920, PH6930, PHC930, PHL930 e PH0910 | Disponible en las calidades PH6920, PH6930, PHC930, PHL930 y PH0910

- > Suitable for machining steels, stainless steels, cast iron, HRSA and non-ferrous

Adequado para maquinação de aços, aços inoxidáveis, ferro fundido, HRSA e não ferrosos | Adecuado para el mecanizado de aceros, aceros inoxidables, hierro fundido, HRSA y no ferrosos



## WCKX > page 426

- > From sizes 02 to 08

De tamanhos de 02 a 08 | De tamaños de 02 a 08

- > Available in grades PH6920 and PH6930

Disponível nos graus PH6920 e PH6930 | Disponible en las calidades PH6920 y PH6930

- > Suitable for machining steels, stainless steels, cast iron and HRSA

Adequado para maquinação de aços, aços inoxidáveis, ferro fundido e HRSA | Adecuado para el mecanizado de aceros, aceros inoxidables, hierro fundido y HRSA

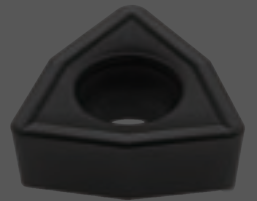

## WCKX-LC > page 427

- > From sizes 05 to 06

De tamanhos de 05 a 06 | De tamaños de 05 a 06

- > Available in grades PH6920 and PH6930

Disponível nos graus PH6920 e PH6930 | Disponible en las calidades PH6920 y PH6930

- > Suitable for machining steels

Adequado para maquinação de aços | Adecuado para el mecanizado de aceros

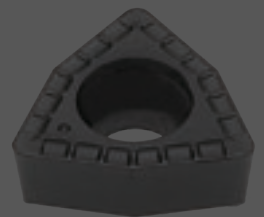

## WCMX > page 427

- > From sizes 03 to 08

De tamanhos de 03 a 08 | De tamaños de 03 a 08

- > Available in grades PH6920, PHC930 and PHL930

Disponível nos graus PH6920, PHC930 e PHL930 | Disponible en las calidades PH6920, PHC930 y PHL930

- > Suitable for machining steels, stainless steels, cast iron and HRSA

Adequado para maquinação de aços, aços inoxidáveis, ferro fundido e HRSA | Adecuado para el mecanizado de aceros, aceros inoxidables, hierro fundido y HRSA

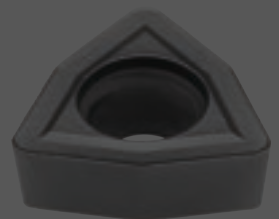

# ISO HOLEMAKING INSERTS CODE KEY

Sistema de codificação para pastilhas de furação ISO | Codificación para plaquetas de furación ISO

|   |  |   |         |
|---|--|---|---------|
| H |  | M |         |
| O |  | V |         |
| P |  | W |         |
| S |  | L |         |
| T |  | A |         |
| C |  | B |         |
| D |  | K |         |
| E |  | R |         |
| F |  | X | Special |

1- Insert shape symbol

| Symbol | m (mm)      | d (mm)      | s (mm) |
|--------|-------------|-------------|--------|
| A      | ±0.005      | ±0.025      | ±0.025 |
| F      | ±0.005      | ±0.013      | ±0.025 |
| C      | ±0.013      | ±0.025      | ±0.025 |
| H      | ±0.013      | ±0.013      | ±0.025 |
| E      | ±0.025      | ±0.025      | ±0.025 |
| G      | ±0.025      | ±0.025      | ±0.13  |
| J      | ±0.005      | ±0.05~±0.13 | ±0.025 |
| K*     | ±0.013      | ±0.05~±0.13 | ±0.025 |
| L*     | ±0.025      | ±0.05~±0.13 | ±0.025 |
| M*     | ±0.08~±0.20 | ±0.05~±0.13 | ±0.13  |
| N*     | ±0.08~±0.20 | ±0.05~±0.13 | ±0.025 |
| U*     | ±0.13~±0.38 | ±0.08~±0.25 | ±0.13  |

\*As a rule, the sides of these inserts are as sintered. Tolerance differs with insert size, for the accuracy of class M, refer to the table on the right.

Triangular inserts with a facet (secondary cutting edge)

| Detailed dimension of M class insert<br>Insert height Tolerances (mm) |       |       |       |       |       |
|---|-------|-------|-------|-------|-------|
| Inscribed circle  |       |       |       |       |       |
| 6.35  | ±0.08 | -     | -     | -     | -     |
| 9.525   | ±0.08 | ±0.08 | ±0.11 | ±0.10 | ±0.13 |
| 12.70   | ±0.13 | ±0.13 | ±0.13 | ±0.15 | -     |
| 15.875  | ±0.15 | ±0.15 | ±0.15 | ±0.18 | -     |
| 19.05   | ±0.15 | ±0.15 | ±0.15 | ±0.18 | -     |
| 25.40   | -     | ±0.18 | -     | -     | -     |
| 31.75   | -     | ±0.25 | -     | -     | -     |

| Inscribed circle Tolerances (mm) |       |       |       |       |       |
|----------------------------------|-------|-------|-------|-------|-------|
| Inscribed circle                 |       |       |       |       |       |
| 6.35                             | ±0.05 | -     | -     | -     | -     |
| 9.525                            | ±0.05 | ±0.05 | ±0.05 | ±0.05 | ±0.05 |
| 12.70                            | ±0.08 | ±0.08 | ±0.08 | ±0.08 | ±0.08 |
| 15.875                           | ±0.10 | ±0.10 | ±0.10 | ±0.10 | ±0.10 |
| 19.05                            | -     | -     | -     | -     | ±0.10 |
| 25.40                            | -     | ±0.13 | -     | -     | ±0.10 |
| 31.75                            | -     | ±0.20 | -     | -     | ±0.12 |

3 - Tolerances symbol

|   |   |   |   |                       |
|---|---|---|---|-----------------------|
| A | B | C | D | E                     |
|   |   |   |   |                       |
| F | G | N | P | O                     |
|   |   |   |   | Other clearance angle |

2 - Normal clearance symbol

ISO **W C K X**

| 4 - Insert symbol |              |   |                           |       |        |              |   |                           |       |        |              |           |                           |                           |  |
|-------------------|--------------|---|---------------------------|-------|--------|--------------|---|---------------------------|-------|--------|--------------|-----------|---------------------------|---------------------------|--|
| symbol            | Type         | Hole type                                 | Chipbreaker               | Shape | symbol | Type         | Hole type                                 | Chipbreaker               | Shape | symbol | Type         | Hole type | Chipbreaker               | Shape                     |  |
| W                 | with hole    | Round hole / one countersink (40°-60°)    | Without chipbreaker       |       | H      | with hole    | Round hole / one countersink (70°-90°)    | Chipbreaker on one side   |       | G      | without hole | with hole | Round hole                | Chipbreaker on both sides |  |
| T                 |              |   | Chipbreaker on one side   |       | C      |              | Round hole / double countersink (70°-90°) | Without chipbreaker       |       | N      |              | -         | Without chipbreaker       |                           |  |
| Q                 | with hole    | Round hole / double countersink (40°-60°) | Without chipbreaker       |       | J      | with hole    | Round hole                                | Chipbreaker on both sides |       | R      | without hole | -         | Chipbreaker on one side   |                           |  |
| U                 |              |   | Chipbreaker on both sides |       | A      |              |   | Without chipbreaker       |       | F      |              | -         | Chipbreaker on both sides |                           |  |
| B                 | without hole | Round hole / one countersink (70°-90°)    | Without chipbreaker       |       | M      | without hole | Round hole                                | Chipbreaker on one side   |       | X      | -            | -         | -                         | On request                |  |

# ISO HOLEMAKING INSERTS CODE KEY

Sistema de codificação para pastilhas de furação ISO | Codificación para plaquetas de furación ISO

| R's  | 35°<br>V's | 55°<br>D's | 80°<br>C's | 90°<br>S's | 60°<br>T's | 80°<br>W's | Ø CI   |       | ANSI   |
|------|------------|------------|------------|------------|------------|------------|--------|-------|--------|
|      |            |            |            |            |            |            | mm     | inch  | Symbol |
| -    | 06         | 04         | -          | 03         | 06         | 02         | 3,97   | 5/32  | 1,20   |
| -    | 08         | 05         | 04         | 04         | 08         | L3         | 4,76   | 3/16  | 1,50   |
| -    | 09         | 06         | 05         | 05         | 09         | 03         | 5,56   | 7/32  | 1,80   |
| 06** | -          | -          | -          | -          | -          | -          | 6,00   | 0,236 |        |
| 06*  | 11         | 07         | 06         | 06         | 11         | 04         | 6,35   | 1/4   | 2,00   |
| 07*  | 13         | 09         | 08         | 07         | 13         | 05         | 7,94   | 5/16  | 2,50   |
| 08*  | -          | -          | -          | -          | -          | -          | 8,00   | 0,315 |        |
| 09*  | 16         | 11         | 09         | 09         | 16         | 06         | 9,525  | 3/8   | 3,00   |
| 10** | -          | -          | -          | -          | -          | -          | 10,00  | 0,394 |        |
| 12** | -          | -          | -          | -          | -          | -          | 12,00  | 0,472 |        |
| 12*  | 22         | 15         | 12         | 12         | 22         | 08         | 12,70  | 1/2   | 4,00   |
| 15*  | 27         | 19         | 16         | 15         | 27         | 10         | 15,875 | 5/8   | 5,00   |
| 16** | -          | -          | -          | -          | -          | -          | 16,00  | 0,63  |        |
| 19*  | 33         | 23         | 19         | 19         | 33         | 13         | 19,05  | 3/4   | 6,00   |
| 20** | -          | -          | -          | -          | -          | -          | 20,00  | 0,787 |        |
| 25** | -          | -          | -          | -          | -          | -          | 25,00  | 0,984 |        |
| 25*  | 44         | 31         | 25         | 25         | 44         | 17         | 25,40  | 1,00  | 8,00   |
| 31*  | 54         | 38         | 32         | 31         | 54         | 21         | 31,75  | 1 1/4 | 10,00  |
| 32** | -          | -          | -          | -          | -          | -          | 32,00  | 1,26  |        |

\* ANSI designation only (Radius Designation is 00)

\*\* Metric designation only (Radius Designation is M0)

According to International Standard ISO 1832 - 2012(E)

"Indexable inserts for cutting tools - Designation"

| ISO | mm    | ANSI | inch  |
|-----|-------|------|-------|
| 01  | 1.59  | 1    | 0.062 |
| T1  | 1.98  | 1.2  | 0.078 |
| 02  | 2.38  | 1.5  | 0.094 |
| 03  | 3.18  | 2    | 0.125 |
| T3  | 3.97  | 2.5  | 0.156 |
| 04  | 4.76  | 3    | 0.188 |
| 05  | 5.56  | 3.5  | 0.219 |
| 06  | 6.35  | 4    | 0.250 |
| 07  | 7.94  | 5    | 0.312 |
| 09  | 9.52  | 6    | 0.375 |
| 12  | 12.70 | 8    | 0.500 |

5 - Insert size symbol

6 - Insert thickness symbol



| 7 - Insert corner symbol   |              |      |      |
|----------------------------|--------------|------|------|
| ISO                        | mm           | inch | ANSI |
| 00                         | Sharp nose   |      | 0    |
| 01                         | 0.10         | .004 | 0.2  |
| 02                         | 0.20         | .008 | 0.5  |
| 04                         | 0.40         | .015 | 1    |
| 08                         | 0.80         | .032 | 2    |
| 12                         | 1.2          | .047 | 3    |
| 16                         | 1.6          | .062 | 4    |
| 20                         | 2.0          | .078 | 5    |
| 24                         | 2.4          | .094 | 6    |
| 28                         | 2.8          | .109 | 7    |
| 32                         | 3.2          | .125 | 8    |
| 00 (inch or M0/<br>metric) | Round insert |      | 0    |

| 7.1* - Insert edges symbol                              |         |   |         |
|---|---------|---|---------|
| For inserts having secondary edges two digits are used: |         |   |         |
| 1 <sup>st</sup> digit is secondary edge                 |         | 2 <sup>nd</sup> digit is secondary edges relief angle |         |
| A   | 45°     | A   | 3°      |
| D   | 60°     | B   | 5°      |
| E   | 75°     | C   | 7°      |
| F   | 85°     | D   | 15°     |
| P   | 90°     | E   | 20°     |
| Z   | special | F   | 25°     |
| *only when required.                                    |         | G   | 30°     |
|   |         | N   | 0°      |
|   |         | P   | 11°     |
|   |         | Z   | special |

| 8 - Cutting edge information |                          |        |
|------------------------------|--------------------------|--------|
| Shape                        | Honing                   | Symbol |
|                              | No honing                | F      |
|                              | With honing              | E      |
|                              | Chamfered<br>No honing   | T      |
|                              | Chamfered<br>with honing | S      |
| *only when required.         |                          |        |

**SP..X** Inserts | Pastilhas | Plaquetas



SPKX



SPKX  
(PHC | PHL grade)



SPHX-LN

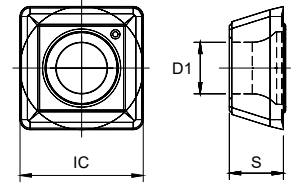

| (1) Geometry code | ISO Reference  | P              |    |    |    | M   |    |    |    | K   |    |    | S   |    |    |    | N   | Dimensions<br>Dimensões<br>Dimensiones<br>(mm) |      |      |      |
|-------------------|----------------|----------------|----|----|----|-----|----|----|----|-----|----|----|-----|----|----|----|-----|--|------|------|------|
|                   |                | PVD            |    |    |    | PVD |    |    |    | PVD |    |    | PVD |    |    |    | UNC |  |      |      |      |
|                   |                | (2) Grade code | 68 | 66 | J3 | 3B  | 68 | 66 | J3 | 3B  | 68 | 66 | 3B  | 68 | 66 | J3 | 3B  | 10   | IC   | S    | D1   |
| 1111281           | SPKX 050204    | ⊗              | ⊗  | ⊗  |    | ⊗   | ⊗  | ⊗  |    | ⊗   | ⊗  |    | ⊗   | ⊗  | ⊗  |    |     | 5,00   | 2,38 | 2,20 | 0,40 |
| 1111282           | SPKX 060204    | ⊗              | ⊗  |    | ⊗  | ⊗   | ⊗  |    | ⊗  | ⊗   | ⊗  | ⊗  | ⊗   | ⊗  |    | ⊗  |     | 6,00   | 2,38 | 2,55 | 0,40 |
| 1142099           | SPHX 060204-LN |                |    |    |    |     |    |    |    |     |    |    |     |    |    | ⊗  |     | 6,00   | 2,38 | 2,55 | 0,40 |
| 1111283           | SPKX 07T308    | ⊗              | ⊗  |    | ⊗  | ⊗   | ⊗  |    | ⊗  | ⊗   | ⊗  | ⊗  | ⊗   | ⊗  |    | ⊗  |     | 7,94   | 3,97 | 2,85 | 0,80 |
| 1111284           | SPKX 090408    | ⊗              | ⊗  | ⊗  | ⊗  | ⊗   | ⊗  | ⊗  | ⊗  | ⊗   | ⊗  | ⊗  | ⊗   | ⊗  | ⊗  |    |     | 9,80   | 4,30 | 4,10 | 0,80 |
| 1111285           | SPKX 110408    | ⊗              | ⊗  |    | ⊗  | ⊗   | ⊗  |    | ⊗  | ⊗   | ⊗  | ⊗  | ⊗   | ⊗  | ⊗  |    |     | 11,50  | 4,80 | 4,40 | 0,80 |
| 1111286           | SPKX 140512    | ⊗              | ⊗  |    | ⊗  | ⊗   | ⊗  |    | ⊗  | ⊗   | ⊗  | ⊗  | ⊗   | ⊗  | ⊗  |    |     | 14,30  | 5,20 | 5,75 | 1,20 |

⊗ Stock item | Produto de stock | Itens de stock    ⊕ Available under request | Disponível sobre consulta | Disponible bajo consulta    ⊗ Available until sold out | Disponível até acabar o stock | Disponible hasta acabar el stock    Insert order code = (1) Geometry Code + (2) Grade Code

**WCKX** Inserts | Pastilhas | Plaquetas

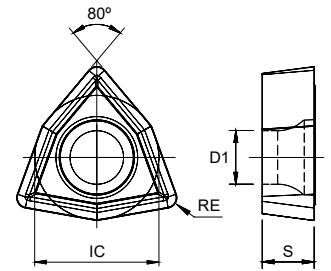

| (1) Geometry code | ISO Reference | P              |    |    |    | M   |    | K   |    | S   |    | Dimensions<br>Dimensões<br>Dimensiones<br>(mm) |      |      |      |
|-------------------|---------------|----------------|----|----|----|-----|----|-----|----|-----|----|--|------|------|------|
|                   |               | PVD            |    |    |    | PVD |    | CVD |    | PVD |    |  |      |      |      |
|                   |               | (2) Grade code | 68 | 66 | I5 | 78  | 68 | 66  | 68 | 66  | 68 | 66   | IC   | S    | D1   |
| 1140300           | WCKX 02T104   | ⊗              | ⊗  | ⊕  | ⊕  | ⊗   | ⊗  | ⊗   | ⊗  | ⊗   | ⊗  | 4,76   | 1,98 | 2,00 | 0,40 |
| 1140276           | WCKX 030204   | ⊗              | ⊗  | ⊕  | ⊕  | ⊗   | ⊗  | ⊗   | ⊗  | ⊗   | ⊗  | 5,56   | 2,38 | 2,55 | 0,40 |
| 1140277           | WCKX 040204   | ⊗              | ⊗  | ⊕  | ⊕  | ⊗   | ⊗  | ⊗   | ⊗  | ⊗   | ⊗  | 6,35   | 2,38 | 2,85 | 0,40 |
| 1140278           | WCKX 050308   | ⊗              | ⊗  | ⊕  | ⊕  | ⊗   | ⊗  | ⊗   | ⊗  | ⊗   | ⊗  | 7,94   | 3,18 | 3,50 | 0,80 |
| 1140279           | WCKX 06T308   | ⊗              | ⊗  | ⊕  | ⊕  | ⊗   | ⊗  | ⊗   | ⊗  | ⊗   | ⊗  | 9,55   | 3,97 | 4,10 | 0,80 |
| 1140280           | WCKX 080408   | ⊗              | ⊗  | ⊕  | ⊕  | ⊗   | ⊗  | ⊗   | ⊗  | ⊗   | ⊗  | 12,70  | 4,76 | 5,60 | 0,80 |

⊗ Stock item | Produto de stock | Itens de stock    ⊕ Available under request | Disponível sobre consulta | Disponible bajo consulta    Insert order code = (1) Geometry Code + (2) Grade Code

# INSERTS

Pastilhas | Plaquetas

## WCKX-LC FOR LOW CARBON STEELS Inserts | Pastilhas | Plaquetas

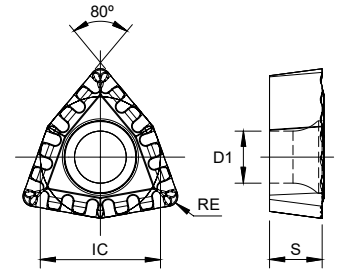

| (1) Geometry code | (2) Grade code | P      |    |  | Dimensions / Dimensões (mm) |      |      |      |
|-------------------|----------------|--------|----|--|-----------------------------|------|------|------|
|                   |                | PVD    |    |  | IC                          | S    | D1   | RE   |
|                   |                | 68     | 66 |  |                             |      |      |      |
| ISO Reference     | PH6920         | PH6930 |    |  |                             |      |      |      |
| 1142068           | WCKX 050308-LC | ⊗      | ⊗  |  | 7,94                        | 3,18 | 3,50 | 0,80 |
| 1142069           | WCKX 06T308-LC | ⊗      | ⊗  |  | 9,55                        | 3,97 | 4,10 | 0,80 |

⊗ Stock item | Produto de stock | Itens de stock      ○ Available under request | Disponível sobre consulta | Disponible bajo consulta

Insert order code = (1) Geometry Code + (2) Grade Code

## WCMX Inserts | Pastilhas | Plaquetas

(PHC | PHL grade)



ISO references for other holemaking systems

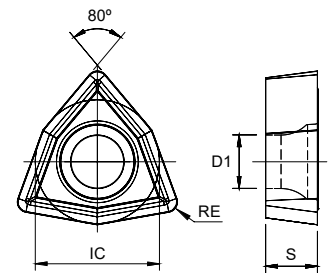

| (1) Geometry code | (2) Grade code | P      |        |        | M      |        |        | K      |        |        | S      |        |    | Dimensions / Dimensões (mm) |      |      |      |
|-------------------|----------------|--------|--------|--------|--------|--------|--------|--------|--------|--------|--------|--------|----|-----------------------------|------|------|------|
|                   |                | PVD    |        |        | PVD    |        |        | PVD    |        |        | PVD    |        |    | IC                          | S    | D1   | RE   |
|                   |                | 68     | J3     | 3B     | 68     | J3     | 3B     | 68     | J3     | 3B     | 68     | J3     | 3B |                             |      |      |      |
| ISO Reference     | PH6920         | PHC930 | PHL930 | PH6920 | PHC930 | PHL930 | PH6920 | PHC930 | PHL930 | PH6920 | PHC930 | PHL930 |    |                             |      |      |      |
| 1120827           | WCMX 030204    | ○      |        | ○      | ○      |        | ○      | ○      |        | ○      | ○      |        | ○  | 5,56                        | 2,38 | 2,80 | 0,40 |
| 1120828           | WCMX 030208    | ⊗      |        | ⊗      | ⊗      |        | ⊗      | ⊗      |        | ⊗      | ⊗      |        | ⊗  | 5,56                        | 2,38 | 2,80 | 0,80 |
| 1120829           | WCMX 040208    | ⊗      | ⊗      |        | ⊗      | ⊗      |        | ⊗      | ⊗      |        | ⊗      | ⊗      |    | 6,35                        | 2,38 | 3,10 | 0,80 |
| 1120830           | WCMX 050308    | ⊗      |        | ⊗      | ⊗      |        | ⊗      | ⊗      |        | ⊗      | ⊗      |        | ⊗  | 7,94                        | 3,18 | 3,20 | 0,80 |
| 1120831           | WCMX 06T308    | ⊗      | ⊗      |        | ⊗      | ⊗      |        | ⊗      | ⊗      |        | ⊗      | ⊗      |    | 9,55                        | 3,97 | 3,70 | 0,80 |
| 1120832           | WCMX 080408    | ⊗      | ⊗      |        | ⊗      | ⊗      |        | ⊗      | ⊗      |        | ⊗      | ⊗      |    | 12,70                       | 4,76 | 4,30 | 0,80 |
| 1120833           | WCMX 080412    | ⊗      |        | ⊗      | ⊗      |        | ⊗      | ⊗      |        | ⊗      | ⊗      |        | ⊗  | 12,70                       | 4,76 | 4,30 | 1,20 |

⊗ Stock item | Produto de stock | Itens de stock      ○ Available under request | Disponível sobre consulta / Disponible bajo consulta      ⊗ Available until sold out | Disponível até acabar o stock / Disponible hasta acabar el stock

Insert order code = (1) Geometry Code + (2) Grade Code



**SPARE  
PARTS**

## **1 CARTRIDGES**

> See page B - 430

## **2 PILOT DRILL AND RDS**

> See page B - 434

## **3 SCREWS AND KEYS**

> See page B - 435

## **4 MDO CARTRIDGE**

> See page B - 436

## **5 VORTEX SCREWS**

> See page B - 437

## **5 MDM AND DRIVE RING**

> See page B - 439

### SIZE ADAPTABLE CARTRIDGE (5mm)

- Unlock the clamping screw of the outer cartridge and move out the cartridge from the body.
- Cut off the outer cartridge's inside contacted part after calculation of the diameter that you want to drill.
- Slick the rough corner surface of the cut cartridge.
- Adhere closely the cartridge to the body not to make chink and fix it with the clamping screw firmly.

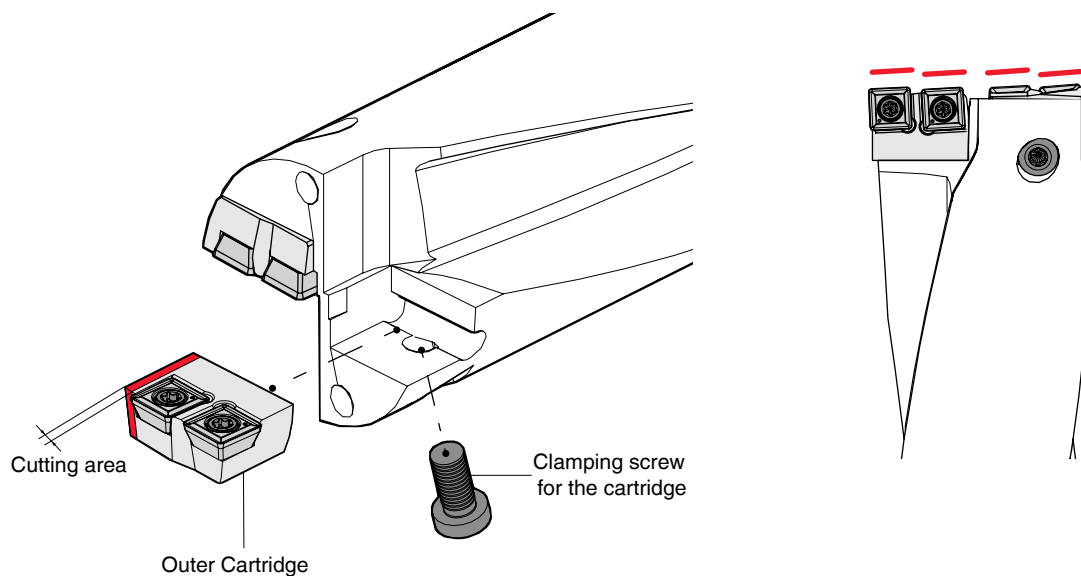

### SCC CARTRIDGE (5mm)

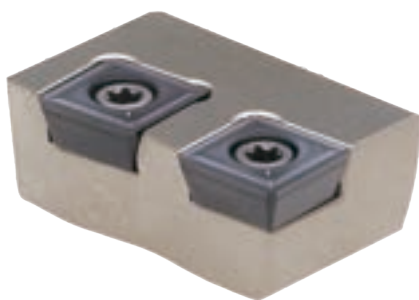

| ØD    | Inner Cartridge |              | Outer Cartridge |              | Insert       | Insert Screw | Torx key | For Drill          | Stock |
|-------|-----------------|--------------|-----------------|--------------|--------------|--------------|----------|--------------------|-------|
|       | Order Code      | Reference    | Order Code      | Reference    |              |              |          |                    |       |
| 50-55 | 184230600       | SCC 050055-I | 184230700       | SCC 050055-O | SP... 090408 | P0350903     | XT15     | SCC 505540-3D & 4D | ○     |
| 55-60 | 184230800       | SCC 055060-I | 184230900       | SCC 055060-O | SP... 090408 | P0350903     | XT15     | SCC 556040-3D & 4D | ○     |
| 60-65 | 184231000       | SCC 060065-I | 184231100       | SCC 060065-O | SP... 110408 | P0401200     | XT15     | SCC 606540-3D & 4D | ○     |
| 65-70 | 184231200       | SCC 065070-I | 184231300       | SCC 065070-O | SP... 110408 | P0401200     | XT15     | SCC 657040-3D & 4D | ○     |
| 70-75 | 184231400       | SCC 070075-I | 184231500       | SCC 070075-O | SP... 110408 | P0401200     | XT15     | SCC 707540-3D & 4D | ○     |
| 75-80 | 184231600       | SCC 075080-I | 184231700       | SCC 075080-O | SP... 140512 | P0501300     | XT20     | SCC 758040-3D & 4D | ○     |

⊗ Stock item | Produto de stock | Itens de stock      ○ Available under request | Disponível sobre consulta | Disponible bajo consulta

## SPARE PARTS

Accesórios | Repuestos

### SCC CARTRIDGE (1mm)







| ØD    | Inner Cartridge |           | Outer Cartridge |           | Insert       | Insert Screw | Torx key | For Drill          | Stock |
|-------|-----------------|-----------|-----------------|-----------|--------------|--------------|----------|--------------------|-------|
|       | Order Code      | Reference | Order Code      | Reference |              |              |          |                    |       |
| 50-51 | 184069500       | CISP 5055 | 184070100       | COSP 5051 | SP... 090408 | P0350903     | XT15     | SCC 505140-3D & 4D | ○     |
| 51-52 | 184069500       | CISP 5055 | 184070200       | COSP 5152 | SP... 090408 | P0350903     | XT15     | SCC 515240-3D & 4D | ○     |
| 52-53 | 184069500       | CISP 5055 | 184070300       | COSP 5253 | SP... 090408 | P0350903     | XT15     | SCC 525340-3D & 4D | ○     |
| 53-54 | 184069500       | CISP 5055 | 184070400       | COSP 5354 | SP... 090408 | P0350903     | XT15     | SCC 535440-3D & 4D | ○     |
| 54-55 | 184069500       | CISP 5055 | 184070500       | COSP 5455 | SP... 090408 | P0350903     | XT15     | SCC 545540-3D & 4D | ○     |
| 55-56 | 184069600       | CISP 5560 | 184070600       | COSP 5556 | SP... 090408 | P0350903     | XT15     | SCC 555640-3D & 4D | ○     |
| 56-57 | 184069600       | CISP 5560 | 184070700       | COSP 5657 | SP... 090408 | P0350903     | XT15     | SCC 565740-3D & 4D | ○     |
| 57-58 | 184069600       | CISP 5560 | 184070800       | COSP 5758 | SP... 090408 | P0350903     | XT15     | SCC 575840-3D & 4D | ○     |
| 58-59 | 184069600       | CISP 5560 | 184070900       | COSP 5859 | SP... 090408 | P0350903     | XT15     | SCC 585940-3D & 4D | ○     |
| 59-60 | 184069600       | CISP 5560 | 184071000       | COSP 5960 | SP... 090408 | P0350903     | XT15     | SCC 596040-3D & 4D | ○     |
| 60-61 | 184069700       | CISP 6065 | 184071100       | COSP 6061 | SP... 110408 | P0401200     | XT15     | SCC 606140-3D & 4D | ○     |
| 61-62 | 184069700       | CISP 6065 | 184071200       | COSP 6162 | SP... 110408 | P0401200     | XT15     | SCC 616240-3D & 4D | ○     |
| 62-63 | 184069700       | CISP 6065 | 184071300       | COSP 6263 | SP... 110408 | P0401200     | XT15     | SCC 626340-3D & 4D | ○     |
| 63-64 | 184069700       | CISP 6065 | 184071400       | COSP 6364 | SP... 110408 | P0401200     | XT15     | SCC 636440-3D & 4D | ○     |
| 64-65 | 184069700       | CISP 6065 | 184071500       | COSP 6465 | SP... 110408 | P0401200     | XT15     | SCC 646540-3D & 4D | ○     |
| 65-66 | 184069800       | CISP 6570 | 184071600       | COSP 6566 | SP... 110408 | P0401200     | XT15     | SCC 656640-3D & 4D | ○     |
| 66-67 | 184069800       | CISP 6570 | 184071700       | COSP 6667 | SP... 110408 | P0401200     | XT15     | SCC 666740-3D & 4D | ○     |
| 67-68 | 184069800       | CISP 6570 | 184071800       | COSP 6768 | SP... 110408 | P0401200     | XT15     | SCC 676840-3D & 4D | ○     |
| 68-69 | 184069800       | CISP 6570 | 184071900       | COSP 6869 | SP... 110408 | P0401200     | XT15     | SCC 686940-3D & 4D | ○     |
| 69-70 | 184069800       | CISP 6570 | 184072000       | COSP 6970 | SP... 110408 | P0401200     | XT15     | SCC 697040-3D & 4D | ○     |
| 70-71 | 184069900       | CISP 7075 | 184250100       | COSP 7071 | SP... 110408 | P0401200     | XT15     | SCC 707140-3D & 4D | ○     |
| 71-72 | 184069900       | CISP 7075 | 184072200       | COSP 7172 | SP... 110408 | P0401200     | XT15     | SCC 717240-3D & 4D | ○     |
| 72-73 | 184069900       | CISP 7075 | 184072300       | COSP 7273 | SP... 110408 | P0401200     | XT15     | SCC 727340-3D & 4D | ○     |
| 73-74 | 184069900       | CISP 7075 | 184072400       | COSP 7374 | SP... 110408 | P0401200     | XT15     | SCC 737440-3D & 4D | ○     |
| 74-75 | 184069900       | CISP 7075 | 184072500       | COSP 7475 | SP... 110408 | P0401200     | XT15     | SCC 747540-3D & 4D | ○     |
| 75-76 | 184070000       | CISP 7580 | 184072600       | COSP 7576 | SP... 140512 | P0501300     | XT20     | SCC 757640-3D & 4D | ○     |
| 76-77 | 184070000       | CISP 7580 | 184072700       | COSP 7677 | SP... 140512 | P0501300     | XT20     | SCC 767740-3D & 4D | ○     |
| 77-78 | 184070000       | CISP 7580 | 184072800       | COSP 7778 | SP... 140512 | P0501300     | XT20     | SCC 777840-3D & 4D | ○     |
| 78-79 | 184070000       | CISP 7580 | 184072900       | COSP 7879 | SP... 140512 | P0501300     | XT20     | SCC 787940-3D & 4D | ○     |
| 79-80 | 184070000       | CISP 7580 | 184073000       | COSP 7980 | SP... 140512 | P0501300     | XT20     | SCC 798040-3D & 4D | ○     |

Stock item | Produto de stock | Itens de stock      ○ Available under request | Disponible sobre consulta | Disponible bajo consulta

## DHC CARTRIDGE



| ØD                      | Inner Cartridge |              | Outer Cartridge |              | Insert       | Insert Screw<br> | Torx key<br> | For Drill          | Stock |
|-------------------------|-----------------|--------------|-----------------|--------------|--------------|--|---|--------------------|-------|
|                         | Order Code      | Reference    | Order Code      | Reference    |              |  |   |                    |       |
| 1 INSERT PER CARTRIDGE  |                 |              |                 |              |              |  |   |                    |       |
| 41                      | 184250300       | CWC 041045-I | 184226700       | CWC 000041-O | WC... 06T308 | P0350903   | XT15  | DHC 004140-5D & 8D | ○     |
| 42                      | 184250300       | CWC 041045-I | 184226800       | CWC 000042-O | WC... 06T308 | P0350903   | XT15  | DHC 004240-5D & 8D | ○     |
| 43                      | 184250300       | CWC 041045-I | 184226900       | CWC 000043-O | WC... 06T308 | P0350903   | XT15  | DHC 004340-5D & 8D | ○     |
| 44                      | 184250300       | CWC 041045-I | 184227000       | CWC 000044-O | WC... 06T308 | P0350903   | XT15  | DHC 004440-5D & 8D | ○     |
| 45                      | 184250300       | CWC 041045-I | 184227100       | CWC 000045-O | WC... 06T308 | P0350903   | XT15  | DHC 004540-5D & 8D | ○     |
| 46                      | 184226400       | CWC 046050-I | 184227200       | CWC 000046-O | WC... 06T308 | P0350903   | XT15  | DHC 004640-5D & 8D | ○     |
| 47                      | 184226400       | CWC 046050-I | 184227300       | CWC 000047-O | WC... 06T308 | P0350903   | XT15  | DHC 004740-5D & 8D | ○     |
| 48                      | 184226400       | CWC 046050-I | 184227400       | CWC 000048-O | WC... 06T308 | P0350903   | XT15  | DHC 004840-5D & 8D | ○     |
| 49                      | 184226400       | CWC 046050-I | 184227500       | CWC 000049-O | WC... 06T308 | P0350903   | XT15  | DHC 004940-5D & 8D | ○     |
| 50                      | 184226400       | CWC 046050-I | 184227600       | CWC 000050-O | WC... 06T308 | P0350903   | XT15  | DHC 005040-5D & 8D | ○     |
| 51                      | 184226500       | CWC 051055-I | 184227700       | CWC 000051-O | WC... 080408 | P0401101   | XT15  | DHC 005140-5D & 8D | ○     |
| 52                      | 184226500       | CWC 051055-I | 184227800       | CWC 000052-O | WC... 080408 | P0401101   | XT15  | DHC 005240-5D & 8D | ○     |
| 53                      | 184226500       | CWC 051055-I | 184227900       | CWC 000053-O | WC... 080408 | P0401101   | XT15  | DHC 005340-5D & 8D | ○     |
| 54                      | 184226500       | CWC 051055-I | 184228000       | CWC 000054-O | WC... 080408 | P0401101   | XT15  | DHC 005440-5D & 8D | ○     |
| 55                      | 184226500       | CWC 051055-I | 184228100       | CWC 000055-O | WC... 080408 | P0401101   | XT15  | DHC 005540-5D & 8D | ○     |
| 56                      | 184226600       | CWC 056059-I | 184228200       | CWC 000056-O | WC... 080408 | P0401101   | XT15  | DHC 005640-5D & 8D | ○     |
| 57                      | 184226600       | CWC 056059-I | 184228300       | CWC 000057-O | WC... 080408 | P0401101   | XT15  | DHC 005740-5D & 8D | ○     |
| 58                      | 184226600       | CWC 056059-I | 184228400       | CWC 000058-O | WC... 080408 | P0401101   | XT15  | DHC 005840-5D & 8D | ○     |
| 59                      | 184226600       | CWC 056059-I | 184228500       | CWC 000059-O | WC... 080408 | P0401101   | XT15  | DHC 005940-5D & 8D | ○     |
| 2 INSERTS PER CARTRIDGE |                 |              |                 |              |              |  |   |                    |       |
| 60-65                   | 184250600       | MDC 060065-I | 184252900       | MDC 060065-O | WC... 050308 | P0300701   | XT08  | DHC 606540-5D & 8D | ○     |
| 65-70                   | 184250700       | MDC 065070-I | 184253000       | MDC 065070-O | WC... 050308 | P0300701   | XT08  | DHC 657040-5D & 8D | ○     |
| 70-75                   | 184250800       | MDC 070075-I | 184063700       | MDC 070075-O | WC... 050308 | P0300701   | XT08  | DHC 707540-5D & 8D | ○     |
| 75-80                   | 184250900       | MDC 075080-I | 184063800       | MDC 075080-O | WC... 06T308 | P0350903   | XT15  | DHC 758040-5D & 8D | ○     |

 Stock item | Produto de stock | Itens de stock
  Available under request | Disponível sobre consulta | Disponible bajo consulta

## SPARE PARTS

Acessórios | Repuestos

### TDC CARTRIDGE



| ØD    | Inner Cartridge |              | Outer Cartridge |              | Insert       | Insert Screw | Torx key | For Drill     | Stock                 |
|-------|-----------------|--------------|-----------------|--------------|--------------|--------------|----------|---------------|-----------------------|
|       | Order Code      | Reference    | Order Code      | Reference    |              |              |          |               |                       |
| 59-65 | 184109200       | TDC 059065-I | 184109300       | TDC 059065-O | WC... 06T308 | P0350903     | XT15     | TDC 596540-3D | <input type="radio"/> |
| 65-70 | 184109400       | TDC 065070-I | 184109500       | TDC 065070-O | WC... 06T308 | P0350903     | XT15     | TDC 657040-3D | <input type="radio"/> |
| 70-75 | 184109600       | TDC 070075-I | 184109700       | TDC 070075-O | WC... 06T308 | P0350903     | XT15     | TDC 707540-3D | <input type="radio"/> |
| 75-80 | 184109800       | TDC 075080-I | 184109900       | TDC 075080-O | WC... 06T308 | P0350903     | XT15     | TDC 758040-3D | <input type="radio"/> |

Stock item | Produto de stock | Itens de stock  Available under request | Disponível sobre consulta | Disponible bajo consulta

### PND CARTRIDGE



| ØD     | Inner Cartridge |              | Outer Cartridge |              | Insert       | Insert Screw | Torx key | For Drill                   | Stock                 |
|--------|-----------------|--------------|-----------------|--------------|--------------|--------------|----------|-----------------------------|-----------------------|
|        | Order Code      | Reference    | Order Code      | Reference    |              |              |          |                             |                       |
| 40-55  | 184110000       | PNC 040055-I | 184128700       | PNC 040055-O | WC... 050308 | P0300701     | XT08     | PND 04032-2D ~ PND 05540-2D | <input type="radio"/> |
| 60-110 | 184110100       | PNC 060110-I | 184128800       | PNC 060110-O | WC... 06T308 | P0350903     | XT15     | PND 06040-2D ~ PND 11050-2D | <input type="radio"/> |

Stock item | Produto de stock | Itens de stock  Available under request | Disponível sobre consulta | Disponible bajo consulta

## PILOT DRILL

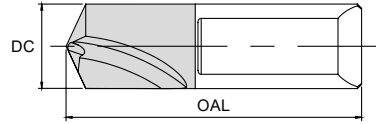

Shank Type

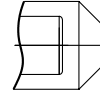

A (with cone)

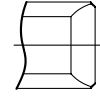

B (with chamfer)

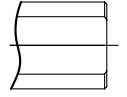

C

| Order Code | Reference | Dimensions   Dimensões   Dimensiones (mm) |     | Type | Oil Hole | For Drill                       | Stock |
|------------|-----------|---|-----|------|----------|---------------------------------|-------|
|            |           | DC  | OAL |      |          |                                 |       |
| 184150900  | MDP 2006  | 6   | 20  | A    | -        | TFD (Ø18,0 - Ø25,0)             | ⊗     |
| 184151000  | MDP 2508  | 8   | 25  | A    | -        | TFD (Ø25,5 - Ø30,0)             | ⊗     |
| 184104100  | MDP 3006  | 6   | 30  | B    | -        | DHS (Ø25 - Ø30)                 | ⊗     |
| 184104400  | MDP 3508  | 8   | 35  | B    | -        | DHS (Ø31 - Ø40)                 | ⊗     |
| 184033100  | MDP 3510  | 10  | 35  | B    | ✓        | DHC (Ø41 - Ø50), MDO (Ø45-Ø55)  | ⊗     |
| 184033200  | MDP 3812  | 12  | 38  | B    | ✓        | DHC (Ø51 - Ø75), MDO (Ø55-Ø75)  | ⊗     |
| 184033300  | MDP 4516  | 16  | 45  | B    | ✓        | DHC (Ø75 - Ø80), MDO (Ø75-Ø100) | ⊗     |
| 184033400  | MDP 4520  | 20  | 45  | C    | ✓        | MDO (Ø100-Ø120)                 | ⊗     |
| 184033500  | MDP 5625  | 25  | 56  | C    | ✓        | MDO (Ø120-Ø160)                 | ⊗     |
| 184033600  | MDP 6830  | 30  | 68  | C    | ✓        | MDO (Ø160-Ø180)                 | ⊗     |

⊗ Stock item | Produto de stock | Itens de stock

○ Available under request | Disponível sobre consulta | Disponible bajo consulta

Pilot Drill  
mounting procedure



## RDS - DRILL SLEEVE

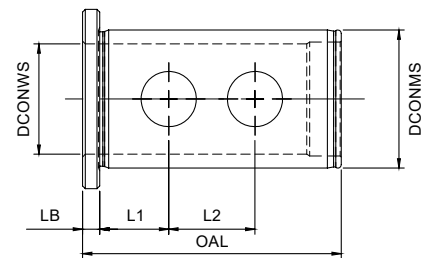

| Order Code | Reference  | Dimensions   Dimensões   Dimensiones (mm) |        |     |    |    |    | Stock |
|------------|------------|---|--------|-----|----|----|----|-------|
|            |            | DCONMS                                    | DCONWS | OAL | L1 | L2 | LB |       |
| 184258900  | RDS 203265 | 32  | 20     | 65  | 20 | -  | 5  | ○     |
| 184259000  | RDS 253265 | 32  | 25     | 65  | 20 | 20 | 5  | ○     |
| 184259100  | RDS 204075 | 40  | 20     | 75  | 20 | -  | 5  | ○     |
| 184259200  | RDS 254075 | 40  | 25     | 75  | 20 | 25 | 5  | ○     |
| 184259300  | RDS 324075 | 40  | 32     | 75  | 20 | 25 | 5  | ○     |
| 184259400  | RDS 205095 | 50  | 20     | 95  | 35 | -  | 5  | ○     |
| 184259500  | RDS 255095 | 50  | 25     | 95  | 35 | -  | 5  | ○     |
| 184259600  | RDS 325095 | 50  | 32     | 95  | 35 | 35 | 5  | ○     |
| 184259700  | RDS 405095 | 50  | 40     | 95  | 35 | 35 | 5  | ○     |

⊗ Stock item | Produto de stock | Itens de stock

○ Available under request | Disponível sobre consulta | Disponible bajo consulta

## SPARE PARTS

Acessórios | Repuestos

## SCREWS & KEYS

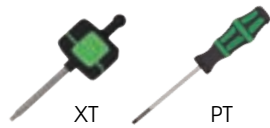

| Order Code<br>Código | Reference<br>Referência<br>Referencia |
|----------------------|---------------------------------------|
| 290058400            | P0180400                              |
| 290025800            | P0180500                              |
| 290095800            | P02004IP                              |
| 290031400            | P0200500                              |
| 290095900            | P02205IP                              |
| 290030600            | P0220500                              |
| 290033100            | P0250503                              |
| 290096000            | P02507IP                              |
| 290031300            | P0250704                              |
| 290096100            | P03007IP                              |
| 290030800            | P0300701                              |
| 290096200            | P03508IP                              |
| 290030900            | P0350903                              |
| 290096300            | P04010IP                              |
| 290031000            | P0401101                              |
| 290047500            | P0401200                              |
| 290095600            | P0500900                              |
| 290096400            | P05013IP                              |
| 290031700            | P0501300                              |
| 290078900            | P0501302                              |

| Order Code | Reference<br>Referência<br>Referencia |
|------------|---------------------------------------|
| 290058600  | XT06IP                                |
| 290011400  | XT06                                  |
| 290012900  | XT07                                  |
| 290096500  | XT08IP                                |
| 290011700  | XT08                                  |
| 290025700  | XT09                                  |
| 290097300  | XT15IP-S35                            |
| 290012400  | XT15                                  |
| 290097400  | XT20IP-S40                            |
| 290013200  | XT20                                  |
| 290014800  | PT15                                  |
| 290014900  | PT20                                  |

## Screw for Cartridge (DIN 912)

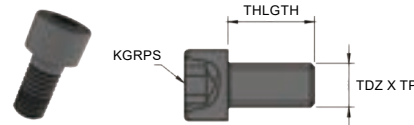

| Order Code<br>Código | Screw    | Dimensions   Dimensões   Dimensiones (mm) |        |       |
|----------------------|----------|---|--------|-------|
|                      |          | TDZ x TP                                  | THLGTH | KGRPS |
| 290042800            | P0501079 | M4 x 0,7                                  | 10,0   | 2,0   |
| 290042900            | P0501279 | M5 x 0,8                                  | 12,0   | 2,5   |
| 290043000            | P0601279 | M6 x 1,0                                  | 12,0   | 2,5   |
| 290043100            | P0601479 | M6 x 1,0                                  | 14,0   | 3,0   |
| 290043600            | P0601679 | M6 x 1,0                                  | 16,0   | 3,0   |
| 290043300            | P0801879 | M8 x 1,25                                 | 18,0   | 4,0   |
| 290043400            | P0802079 | M8 x 1,25                                 | 20,0   | 4,0   |
| 290043500            | P0802579 | M8 x 1,25                                 | 25,0   | 4,0   |

## Screw for Cartridge (ISO 7380)

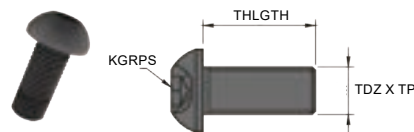

| Order Code<br>Código | Screw    | Dimensions   Dimensões   Dimensiones (mm) |        |       |
|----------------------|----------|---|--------|-------|
|                      |          | TDZ x TP                                  | THLGTH | KGRPS |
| 290042500            | P0401078 | M4 x 0,7                                  | 10,0   | 2,0   |
| 290042600            | P0501078 | M5 x 0,8                                  | 10,0   | 2,5   |
| 290042700            | P0501278 | M5 x 0,8                                  | 12,0   | 2,5   |

## Fixing Screw and Clamping Bolt for Pilot Drill (DIN 916)

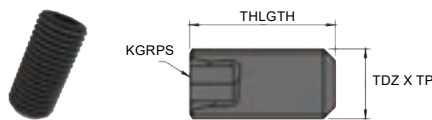

| Order Code<br>Código | Screw    | Dimensions   Dimensões   Dimensiones (mm) |        |       |
|----------------------|----------|---|--------|-------|
|                      |          | TDZ x TP                                  | THLGTH | KGRPS |
| 290040100            | P0400875 | M4 x 0,7                                  | 8,0    | 2,0   |
| 290040200            | P0500875 | M5 x 0,8                                  | 8,0    | 2,5   |
| 290040300            | P0501075 | M5 x 0,8                                  | 10,0   | 2,5   |
| 290040400            | P0601075 | M6 x 1,0                                  | 10,0   | 3,0   |
| 290040500            | P0601275 | M6 x 1,0                                  | 12,0   | 3,0   |
| 290040600            | P0801275 | M8 x 1,25                                 | 12,0   | 4,0   |
| 290040700            | P0801575 | M8 x 1,25                                 | 15,0   | 4,0   |
| 290040800            | P1001575 | M10 x 1,5                                 | 15,0   | 5,0   |
| 290040900            | P1002075 | M10 x 1,5                                 | 20,0   | 5,0   |
| 290041000            | P1202075 | M12 x 1,75                                | 20,0   | 6,0   |
| 290041100            | P1202575 | M12 x 1,75                                | 25,0   | 6,0   |
| 290041200            | P1402575 | M14 x 2,0                                 | 25,0   | 6,0   |
| 290041300            | P1602575 | M16 x 2,0                                 | 25,0   | 8,0   |

## Adjustment Screw for Pilot Drill (DIN 916 w/ hole)

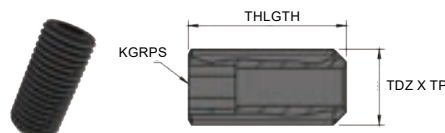

| Order Code<br>Código | Screw    | Dimensions   Dimensões   Dimensiones (mm) |        |       |
|----------------------|----------|---|--------|-------|
|                      |          | TDZ x TP                                  | THLGTH | KGRPS |
| 290041400            | P0601076 | M6 x 1,0                                  | 10,0   | 3,0   |
| 290041500            | P0801576 | M8 x 1,25                                 | 15,0   | 4,0   |
| 290097100            | P1001576 | M10 x 1,5                                 | 15,0   | 5,0   |
| 290041800            | P1202076 | M12 x 1,75                                | 20,0   | 6,0   |
| 290041900            | P1402076 | M14 x 2,0                                 | 20,0   | 6,0   |

## VORTEX SPARE PARTS - MDO CARTRIDGE



| ØD                      | Inner Cartridge |              | Outer Cartridge |              | Insert       | Insert Screw | Torx key | For Drill    | Stock |
|-------------------------|-----------------|--------------|-----------------|--------------|--------------|--------------|----------|--------------|-------|
|                         | Order Code      | Reference    | Order Code      | Reference    |              |              |          |              |       |
| 2 INSERTS PER CARTRIDGE |                 |              |                 |              |              |              |          |              |       |
| 45-50                   | 184062000       | MDC 045050-I | 184252600       | MDC 045050-O | WC... 030204 | P0220500     | XT07     | MDO 04505013 | 📦     |
| 50-55                   | 184250400       | MDC 050055-I | 184252700       | MDC 050055-O | WC... 030204 | P0220500     | XT07     | MDO 05005513 | 📦     |
| 55-60                   | 184250500       | MDC 055060-I | 184252800       | MDC 055060-O | WC... 040204 | P0250503     | XT08     | MDO 05506016 | 📦     |
| 60-65                   | 184250600       | MDC 060065-I | 184252900       | MDC 060065-O | WC... 050308 | P0300701     | XT08     | MDO 06006516 | 📦     |
| 65-70                   | 184250700       | MDC 065070-I | 184253000       | MDC 065070-O | WC... 050308 | P0300701     | XT08     | MDO 06507016 | 📦     |
| 70-75                   | 184250800       | MDC 070075-I | 184063700       | MDC 070075-O | WC... 050308 | P0300701     | XT08     | MDO 07007522 | 📦     |
| 75-80                   | 184250900       | MDC 075080-I | 184063800       | MDC 075080-O | WC... 06T308 | P0350903     | XT15     | MDO 07508022 | 📦     |
| 80-85                   | 184251000       | MDC 080085-I | 184063900       | MDC 080085-O | WC... 06T308 | P0350903     | XT15     | MDO 08008522 | 📦     |
| 85-90                   | 184251100       | MDC 085090-I | 184064000       | MDC 085090-O | WC... 06T308 | P0350903     | XT15     | MDO 08509027 | 📦     |
| 90-95                   | 184251200       | MDC 090095-I | 184064100       | MDC 090095-O | WC... 06T308 | P0350903     | XT15     | MDO 09009527 | 📦     |
| 95-100                  | 184251300       | MDC 095100-I | 184064200       | MDC 095100-O | WC... 06T308 | P0350903     | XT15     | MDO 09510027 | 📦     |
| 3 INSERTS PER CARTRIDGE |                 |              |                 |              |              |              |          |              |       |
| 100-105                 | 184251400       | MDC 100105-I | 184064300       | MDC 100105-O | WC... 050308 | P0300701     | XT08     | MDO 10010532 | 📦     |
| 105-110                 | 184251500       | MDC 105110-I | 184253100       | MDC 105110-O | WC... 06T308 | P0350903     | XT15     | MDO 10511032 | 📦     |
| 110-115                 | 184251600       | MDC 110115-I | 184253200       | MDC 110115-O | WC... 06T308 | P0350903     | XT15     | MDO 11011532 | 📦     |
| 115-120                 | 184251700       | MDC 115120-I | 184253300       | MDC 115120-O | WC... 06T308 | P0350903     | XT15     | MDO 11512040 | 📦     |
| 120-125                 | 184251800       | MDC 120125-I | 184253400       | MDC 120125-O | WC... 06T308 | P0350903     | XT15     | MDO 12012540 | 📦     |
| 125-130                 | 184251900       | MDC 125130-I | 184253500       | MDC 125130-O | WC... 06T308 | P0350903     | XT15     | MDO 12513040 | 📦     |
| 130-135                 | 184252000       | MDC 130135-I | 184068900       | MDC 130135-O | WC... 06T308 | P0350903     | XT15     | MDO 13013540 | 📦     |
| 135-140                 | 184252100       | MDC 135140-I | 184069000       | MDC 135140-O | WC... 06T308 | P0350903     | XT15     | MDO 13514040 | 📦     |
| 140-150                 | 184252200       | MDC 140150-I | 184253600       | MDC 140150-O | WC... 080408 | P0401101     | XT15     | MDO 14015050 | 📦     |
| 150-160                 | 184252300       | MDC 150160-I | 184069200       | MDC 150160-O | WC... 080408 | P0401101     | XT15     | MDO 15016050 | 📦     |
| 160-170                 | 184252400       | MDC 160170-I | 184069300       | MDC 160170-O | WC... 080408 | P0401101     | XT15     | MDO 16017050 | 📦     |
| 170-180                 | 184252500       | MDC 170180-I | 184069400       | MDC 170180-O | WC... 080408 | P0401101     | XT15     | MDO 17018050 | 📦     |

📦 Stock item | Produto de stock | Itens de stock

○ Available under request | Disponível sobre consulta | Disponible bajo consulta

## Adjusting the cutting diameter of Vortex MDO 10D

- 1 - Unscrew the clamping bolt that holds the outer cartridge in place and remove it from the drill body.
- 2 - Use a milling tool to carefully cut out the section of the outer cartridge that will come into contact with the material being drilled, making sure to calculate the correct diameter beforehand.
- 3 - Smooth out any sharp edges on the cartridge.
- 4 - Attach the cartridge securely to the drill body, ensuring there are no gaps between the two, and tighten the clamping bolt firmly to keep it in place.

Example: for a standard diameter of Ø120mm and you want Ø116mm you should cut 2mm.

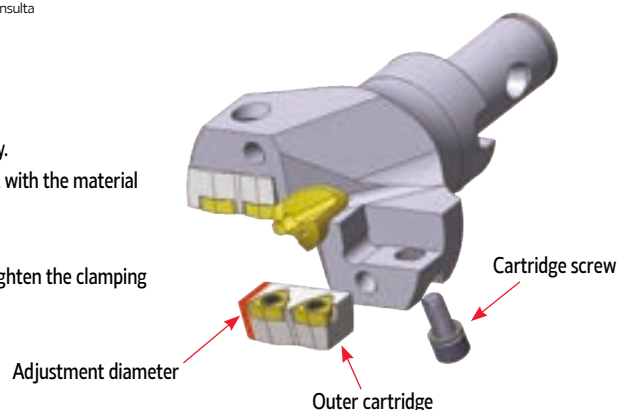

**VORTEX SPARE PARTS - SCREWS**

| Vortex Drill | (3) Fixing Screw for Pilot Drill |          | (4) Clamping Bolt for Pilot Drill |          | (5) Adjustment Screw for Pilot Drill |          | (7) Screw for Cartridge |          |
|--------------|----------------------------------|----------|-----------------------------------|----------|--------------------------------------|----------|-------------------------|----------|
|              | Order Code                       | Screw    | Order Code                        | Screw    | Order Code                           | Screw    | Order Code              | Screw    |
| MDO 04505013 | 290040100                        | P0400875 | 290040400                         | P0601075 | 290041400                            | P0601076 | 290042500               | P0401078 |
| MDO 05005513 | 290040100                        | P0400875 | 290040400                         | P0601075 | 290041400                            | P0601076 | 290042500               | P0401078 |
| MDO 05506016 | 290040100                        | P0400875 | 290040600                         | P0801275 | 290041500                            | P0801576 | 290042700               | P0501278 |
| MDO 06006516 | 290040200                        | P0500875 | 290040600                         | P0801275 | 290041500                            | P0801576 | 290042700               | P0501278 |
| MDO 06507016 | 290040200                        | P0500875 | 290040600                         | P0801275 | 290041500                            | P0801576 | 290042700               | P0501278 |
| MDO 07007522 | 290040200                        | P0500875 | 290040700                         | P0801575 | 290041500                            | P0801576 | 290042700               | P0501278 |
| MDO 07508022 | 290040400                        | P0601075 | 290040900                         | P1002075 | 290097100                            | P1001676 | 290043000               | P0601279 |
| MDO 08008522 | 290040400                        | P0601075 | 290040900                         | P1002075 | 290097100                            | P1001676 | 290043100               | P0601479 |
| MDO 08509027 | 290040400                        | P0601075 | 290040900                         | P1002075 | 290097100                            | P1001876 | 290043600               | P0601679 |
| MDO 09009527 | 290040400                        | P0601075 | 290040900                         | P1002075 | 290097100                            | P1001876 | 290043600               | P0601679 |
| MDO 09510027 | 290040400                        | P0601075 | 290040900                         | P1002075 | 290097100                            | P1001876 | 290043600               | P0601679 |
| MDO 10010532 | 290040400                        | P0601075 | 290041000                         | P1202075 | 290041800                            | P1202076 | 290043300               | P0801879 |
| MDO 10511032 | 290040400                        | P0601075 | 290041000                         | P1202075 | 290041800                            | P1202076 | 290043300               | P0801879 |
| MDO 11011532 | 290040400                        | P0601075 | 290041000                         | P1202075 | 290041800                            | P1202076 | 290043300               | P0801879 |
| MDO 11512040 | 290040400                        | P0601075 | 290041100                         | P1202575 | 290041900                            | P1402076 | 290043400               | P0802079 |
| MDO 12012540 | 290040400                        | P0601075 | 290041200                         | P1402575 | 290041900                            | P1402076 | 290043500               | P0802579 |
| MDO 12513040 | 290040400                        | P0601075 | 290041200                         | P1402575 | 290041900                            | P1402076 | 290043500               | P0802579 |
| MDO 13013540 | 290040400                        | P0601075 | 290041200                         | P1402575 | 290041900                            | P1402076 | 290043500               | P0802579 |
| MDO 13514040 | 290040400                        | P0601075 | 290041200                         | P1402575 | 290041900                            | P1402076 | 290043500               | P0802579 |
| MDO 14015050 | 290040400                        | P0601075 | 290041200                         | P1402575 | 290041900                            | P1402076 | 290043500               | P0802579 |
| MDO 15016050 | 290040400                        | P0601075 | 290041200                         | P1402575 | 290041900                            | P1402076 | 290043500               | P0802579 |
| MDO 16017050 | 290040400                        | P0601075 | 290041300                         | P1602575 | 290041900                            | P1402076 | 290043500               | P0802579 |
| MDO 17018050 | 290040400                        | P0601075 | 290041300                         | P1602575 | 290041900                            | P1402076 | 290043500               | P0802579 |

Multicut

Jet Drills

Integrex Drills

Vortex Drills

Trepanning Drills

Inserts

Spare Parts

Technical Data

Solid Carbide Drills

| (9) Fixation Screw for MDS Shank, MDE Extension, MDM Reducer |                   |          |
|--|-------------------|----------|
| DC / BD  | Order Code Código | Screw    |
| 28   | 290032400         | P0801280 |
| 32   | 290032400         | P0801280 |
| 40   | 290032500         | P1001580 |
| 48   | 290032600         | P1201880 |
| 58   | 290039600         | P1202080 |
| 70   | 290032800         | P1602780 |
| 80   | 290032800         | P1602780 |

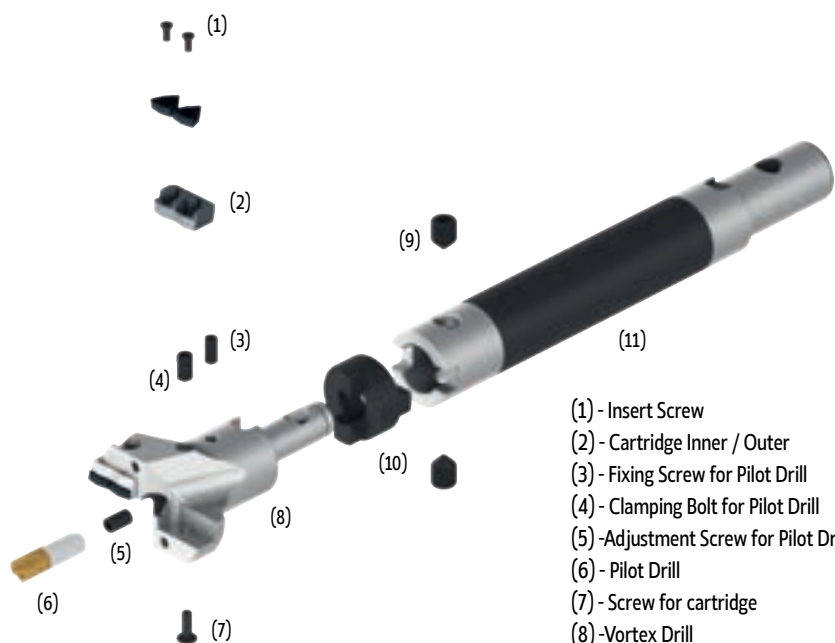

- (1) - Insert Screw
- (2) - Cartridge Inner / Outer
- (3) - Fixing Screw for Pilot Drill
- (4) - Clamping Bolt for Pilot Drill
- (5) - Adjustment Screw for Pilot Drill
- (6) - Pilot Drill
- (7) - Screw for cartridge
- (8) - Vortex Drill
- (9) - Fixation Screw
- (10) - Drive Ring
- (11) - MDS Shank or MDE Extension

## VORTEX SPARE PARTS - SCREWS

## Fixing Screw and Clamping Bolt for Pilot Drill (DIN 916)

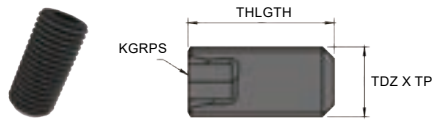

| Order Code<br>Código | Screw    | Dimensions   Dimensões   Dimensiones (mm) |        |       |
|----------------------|----------|---|--------|-------|
|                      |          | TDZ x TP                                  | THLGTH | KGRPS |
| 290040100            | P0400875 | M4 x 0,7                                  | 8,0    | 2,0   |
| 290040200            | P0500875 | M5 x 0,8                                  | 8,0    | 2,5   |
| 290040400            | P0601075 | M6 x 1,0                                  | 10,0   | 3,0   |
| 290040500            | P0601275 | M6 x 1,0                                  | 12,0   | 3,0   |
| 290040700            | P0801575 | M8 x 1,25                                 | 15,0   | 4,0   |
| 290040900            | P1002075 | M10 x 1,5                                 | 20,0   | 5,0   |
| 290041000            | P1202075 | M12 x 1,75                                | 20,0   | 6,0   |
| 290041100            | P1202575 | M12 x 1,75                                | 25,0   | 6,0   |
| 290041200            | P1402575 | M14 x 2,0                                 | 25,0   | 6,0   |
| 290041300            | P1602575 | M16 x 2,0                                 | 25,0   | 8,0   |

## Fixation Screw for MDS Shank, MDE Extension, MDM Reducer

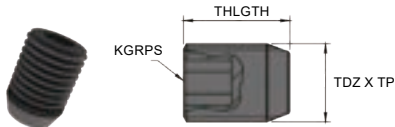

| Order Code<br>Código | Screw    | Dimensions   Dimensões   Dimensiones (mm) |        |       |
|----------------------|----------|---|--------|-------|
|                      |          | TDZ x TP                                  | THLGTH | KGRPS |
| 290032400            | P0801280 | M8  | 12,0   | 4,0   |
| 290032500            | P1001580 | M10                                       | 15,0   | 5,0   |
| 290032600            | P1201880 | M12                                       | 18,0   | 6,0   |
| 290039600            | P1202080 | M12                                       | 20,0   | 6,0   |
| 290032800            | P1602780 | M16                                       | 27,0   | 8,0   |

## Insert Screw



| Order Code | Screw    |
|------------|----------|
| 290030600  | P0220500 |
| 290033100  | P0250503 |
| 290030800  | P0300701 |
| 290030900  | P0350903 |
| 290031000  | P0401101 |

## Adjustment Screw for Pilot Drill (DIN 916 w/ hole)

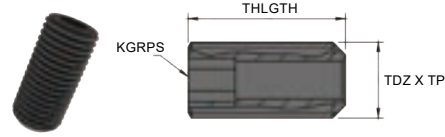

| Order Code<br>Código | Screw    | Dimensions   Dimensões   Dimensiones (mm) |        |       |
|----------------------|----------|---|--------|-------|
|                      |          | TDZ x TP                                  | THLGTH | KGRPS |
| 290041400            | P0601076 | M6 x 1,0                                  | 10,0   | 3,0   |
| 290041500            | P0801576 | M8 x 1,25                                 | 15,0   | 4,0   |
| 290097100            | P1001676 | M10 x 1,5                                 | 16,0   | 5,0   |
| 290097100            | P1001876 | M10 x 1,5                                 | 18,0   | 5,0   |
| 290041800            | P1202076 | M12 x 1,75                                | 20,0   | 6,0   |
| 290041900            | P1402076 | M14 x 2,0                                 | 20,0   | 6,0   |

## Screw for Cartridge (ISO 7380)

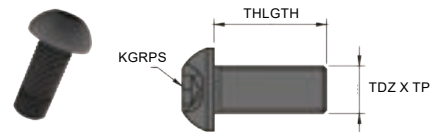

| Order Code<br>Código | Screw    | Dimensions   Dimensões   Dimensiones (mm) |        |       |
|----------------------|----------|---|--------|-------|
|                      |          | TDZ x TP                                  | THLGTH | KGRPS |
| 290042500            | P0401078 | M4 x 0,7                                  | 10,0   | 2,0   |
| 290042700            | P0501278 | M5 x 0,8                                  | 12,0   | 2,5   |

## Screw for Cartridge (DIN 912)

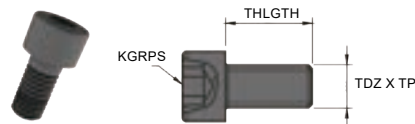

| Order Code<br>Código | Screw    | Dimensions   Dimensões   Dimensiones (mm) |        |       |
|----------------------|----------|---|--------|-------|
|                      |          | TDZ x TP                                  | THLGTH | KGRPS |
| 290043000            | P0601279 | M6 x 1,0                                  | 12,0   | 2,5   |
| 290043100            | P0601479 | M6 x 1,0                                  | 14,0   | 3,0   |
| 290043600            | P0601679 | M6 x 1,0                                  | 16,0   | 3,0   |
| 290043300            | P0801879 | M8 x 1,25                                 | 18,0   | 4,0   |
| 290043400            | P0802079 | M8 x 1,25                                 | 20,0   | 4,0   |
| 290043500            | P0802579 | M8 x 1,25                                 | 25,0   | 4,0   |

## MDM - REDUCER

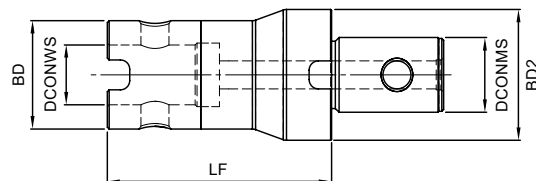

| Order Code | Reference    | Dimensions   Dimensões   Dimensiones (mm) |        |    |     |     | Drive Ring D1 | Drive Ring D2 | Stock |
|------------|--------------|---|--------|----|-----|-----|---------------|---------------|-------|
|            |              | DCONWS                                    | DCONMS | BD | BD2 | LF  |               |               |       |
| 184253900  | MDM 16100130 | 13  | 16     | 28 | 32  | 100 | MDR 1028      | MDR 1032      | ☺     |
| 184254000  | MDM 22100160 | 16  | 22     | 32 | 40  | 100 | MDR 1032      | MDR 1240      | ☺     |
| 184254100  | MDM 27100220 | 22  | 27     | 40 | 48  | 100 | MDR 1240      | MDR 1248      | ☺     |
| 184254200  | MDM 32100130 | 13  | 32     | 28 | 58  | 100 | MDR 1028      | MDR 1458      | ○     |
| 184254300  | MDM 32100160 | 16  | 32     | 32 | 58  | 100 | MDR 1032      | MDR 1458      | ☺     |
| 184254400  | MDM 32100220 | 22  | 32     | 40 | 58  | 100 | MDR 1240      | MDR 1458      | ○     |
| 184254500  | MDM 32100270 | 27  | 32     | 48 | 58  | 100 | MDR 1248      | MDR 1458      | ○     |
| 184254600  | MDM 40100320 | 32  | 40     | 58 | 70  | 100 | MDR 1458      | MDR 1470      | ☺     |
| 184254700  | MDM 50080130 | 13  | 50     | 28 | 80  | 80  | MDR 1028      | MDR 1680      | ○     |
| 184254800  | MDM 50080160 | 16  | 50     | 32 | 80  | 80  | MDR 1032      | MDR 1680      | ○     |
| 184254900  | MDM 50080220 | 22  | 50     | 40 | 80  | 80  | MDR 1240      | MDR 1680      | ○     |
| 184255000  | MDM 50080270 | 27  | 50     | 48 | 80  | 80  | MDR 1248      | MDR 1680      | ☺     |
| 184255100  | MDM 50080320 | 32  | 50     | 58 | 80  | 80  | MDR 1458      | MDR 1680      | ○     |
| 184250200  | MDM 50150400 | 40  | 50     | 70 | 80  | 150 | MDR 1470      | MDR 1680      | ☺     |

☺ Stock item | Produto de stock | Itens de stock

○ Available under request | Disponível sobre consulta | Disponible bajo consulta

## DRIVE RING

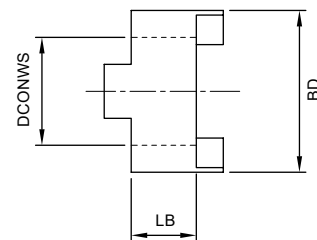

| Order Code | Reference | Dimensions   Dimensões   Dimensiones (mm) |        |    | Stock |
|------------|-----------|---|--------|----|-------|
|            |           | BD  | DCONWS | LB |       |
| 184021600  | MDR 1028  | 28  | 13     | 10 | ○     |
| 184021700  | MDR 1032  | 32  | 16     | 10 | ○     |
| 184022100  | MDR 1240  | 40  | 22     | 12 | ○     |
| 184022200  | MDR 1248  | 48  | 27     | 12 | ○     |
| 184022300  | MDR 1458  | 58  | 32     | 14 | ○     |
| 184022400  | MDR 1470  | 70  | 40     | 14 | ○     |
| 184022500  | MDR 1680  | 80  | 50     | 16 | ○     |

☺ Stock item | Produto de stock | Itens de stock

○ Available under request | Disponível sobre consulta | Disponible bajo consulta

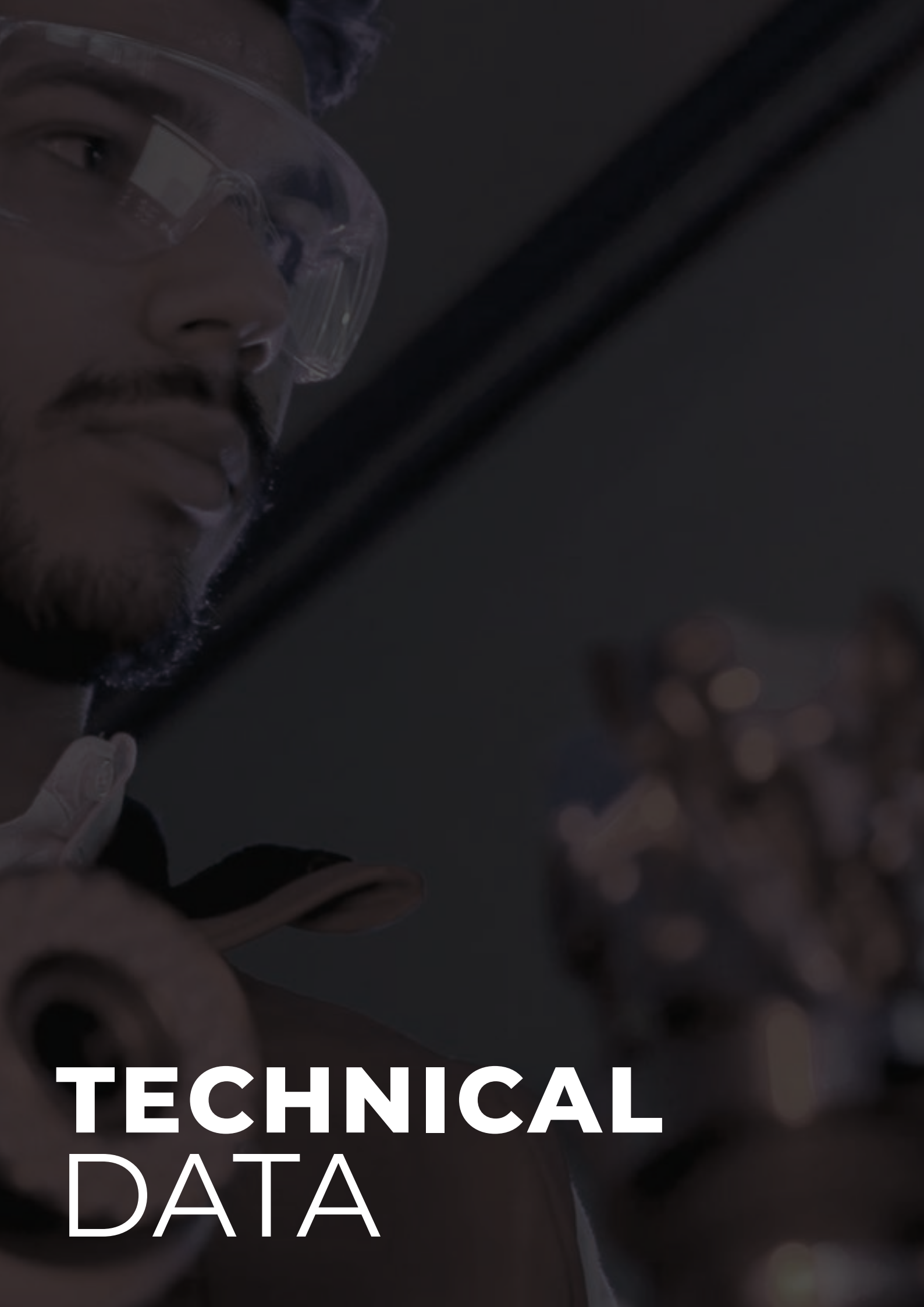

# TECHNICAL DATA

## **1 HOLEMAKING GRADES**

> See page B - 442

## **2 TDS AND TDC DRILL TYPE**

> See page B - 445

## **3 SCS AND SCC DRILL TYPE**

> See page B - 448

## **4 DHS, DHC AND TFD DRILL TYPE**

> See page B - 449

## **5 VORTEX DRILL - CUTTING PARAMETERS AND ADJUSTMENTS**

> See page B - 450

# B TECHNICAL DATA Dados técnicos | Datos técnicos

## HOLEMAKING

Multi cut

Jet Drills

Integrex Drills

Vortex Drills

Trepanning Drills

Inserts

Spare Parts

Technical Data

Solid Carbide Drills

|   | 1 | 5 | 10 | 15 | 20 | 25 | 30 | 35 | 40 | 45 | 50 |     |
|---|---|---|----|----|----|----|----|----|----|----|----|-----|
| <b>P</b><br>STEEL                               |   |   |    |    |    |    |    |    |    |    |    | PVD |
|   |   |   |    |    |    |    |    |    |    |    |    |     |
|   |   |   |    |    |    |    |    |    |    |    |    |     |
|   |   |   |    |    |    |    |    |    |    |    |    |     |
|   |   |   |    |    |    |    |    |    |    |    |    |     |
|   |   |   |    |    |    |    |    |    |    |    |    |     |
| <b>M</b><br>STAINLESS<br>STEEL                  |   |   |    |    |    |    |    |    |    |    |    | PVD |
|   |   |   |    |    |    |    |    |    |    |    |    |     |
|   |   |   |    |    |    |    |    |    |    |    |    |     |
|   |   |   |    |    |    |    |    |    |    |    |    |     |
|   |   |   |    |    |    |    |    |    |    |    |    |     |
|   |   |   |    |    |    |    |    |    |    |    |    |     |
| <b>K</b><br>CAST IRON                           |   |   |    |    |    |    |    |    |    |    |    | PVD |
|   |   |   |    |    |    |    |    |    |    |    |    |     |
|   |   |   |    |    |    |    |    |    |    |    |    |     |
|   |   |   |    |    |    |    |    |    |    |    |    |     |
|   |   |   |    |    |    |    |    |    |    |    |    |     |
|   |   |   |    |    |    |    |    |    |    |    |    |     |
| <b>N</b><br>ALUMINIUM                           |   |   |    |    |    |    |    |    |    |    |    | UNC |
|   |   |   |    |    |    |    |    |    |    |    |    |     |
| <b>S</b><br>HEAT RESISTANT /<br>TITANIUM ALLOYS |   |   |    |    |    |    |    |    |    |    |    | PVD |
|   |   |   |    |    |    |    |    |    |    |    |    |     |
|   |   |   |    |    |    |    |    |    |    |    |    |     |
|   |   |   |    |    |    |    |    |    |    |    |    | CVD |

## PVD GRADES

### PH6920

P10-P35  
M10-M25  
K10-K30

Coated grade over a tough wear resistance substrate for general purpose machining.

### PHU920

P10-P35  
M10-M25  
K10-K30

With high thermal shock resistance and suitable for dry and wet machining, the PHU920 grade is recommended for steels, stainless steels and cast iron.

### PH6930

P20-P40  
M20-M30  
K20-K40

Grade suitable for applications with instability conditions. Excellent solution for medium cutting speed applications.

### PHL930

P20-P40  
M20-M30  
K20-K40  
S20-S30

Grade suitable for applications with instability conditions. Excellent solution for medium cutting speed applications. Coated in Yellow to be visually distinguishable.

### PHP930

P20-P40  
K10-K30

Due to the reduced cutting speed in the central area of the drill, a tougher grade is recommended for the inner insert. (Inner Insert)

### PHH930

M20-M40  
S20-S30

### PHP920

P10-P35  
K10-K30

First choice for stable machining and improved surface finish. Recommended for outer edge if chattering occurs. (Outer Insert)

### PHH920

M10-M25  
S15-S30

### PH0910

N05-N10

Uncoated carbide micro-grain grade combining a good abrasive wear resistance and toughness. Suitable for rough to finish operations of aluminum alloys.

## CVD GRADE

### PHS130

P10-P35  
K20-K40

First choice for high speeds and high efficiency machining, abrasion resistance and longer tool life. (Outer Insert)

## GRADES RECOMMENDATION FOR HOLEMAKING SYSTEMS

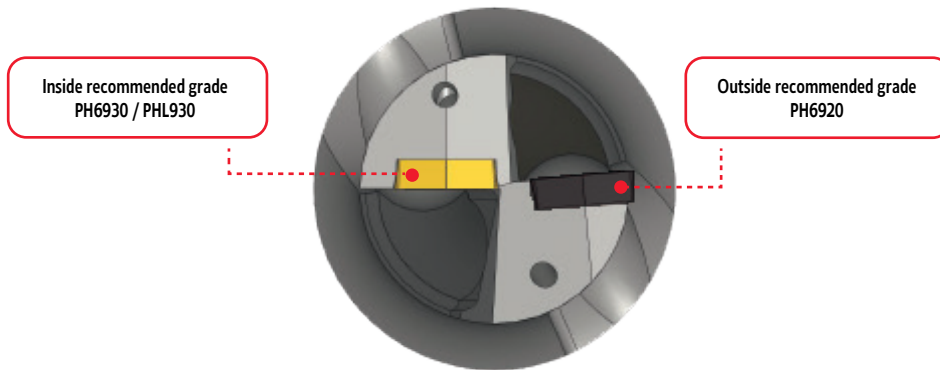

Note: This recommendation should be applied on High Alloy Steels, Stainless Steels and HRSA materials.

### PHU920

Combining both excellent thermal resistance and excellent surface quality, the PHU920 grade is recommended for steels, stainless steels and cast iron.

Because of its surface quality and thermal resistance it is able to prevent built-up-edge in both low-alloy steels and stainless steels, making it a very versatile grade.

- High thermal shock resistance
- Carefully engineered surface quality
- Suitable for dry and wet machining
- Color: Grey



## RECOMMENDED SPEEDS AND FEEDS

| ISO | Material Group<br>Grupo Materiais<br>Grupo Materiales | Vc (m/min) | f (mm/rev) |           |           |           |           |           |           |
|-----|---|------------|------------|-----------|-----------|-----------|-----------|-----------|-----------|
|     |   |            | Ø13-15,5   | Ø16-20    | Ø20,5-25  | Ø25,5-30  | Ø31-41    | Ø42-58    | Ø59-80    |
| P   | Unalloyed steel (-0,25%)                              | 180-260    | 0,05-0,08  | 0,06-0,10 | 0,07-0,12 | 0,09-0,15 | 0,11-0,18 | 0,15-0,28 | 0,11-0,18 |
|     | Low-alloy steel (0,25%-)                              | 150-240    | 0,05-0,08  | 0,06-0,10 | 0,07-0,12 | 0,09-0,15 | 0,11-0,18 | 0,15-0,28 | 0,11-0,18 |
|     | Low-alloy steel                                       | 120-240    | 0,05-0,08  | 0,06-0,10 | 0,07-0,12 | 0,09-0,15 | 0,11-0,18 | 0,15-0,28 | 0,11-0,18 |
|     | High-alloy steel                                      | 130-220    | 0,05-0,08  | 0,06-0,10 | 0,07-0,12 | 0,09-0,15 | 0,11-0,18 | 0,15-0,28 | 0,11-0,18 |
| M   | Stainless steel                                       | 150-220    | 0,04-0,08  | 0,05-0,09 | 0,06-0,12 | 0,07-0,13 | 0,08-0,16 | 0,10-0,20 | 0,08-0,16 |
| K   | Grey cast iron  | 150-250    | 0,05-0,11  | 0,07-0,13 | 0,08-0,12 | 0,10-0,18 | 0,14-0,26 | 0,18-0,35 | 0,14-0,26 |
|     | Cast iron with nodular cast                           | 120-200    | 0,05-0,11  | 0,06-0,13 | 0,07-0,12 | 0,08-0,18 | 0,14-0,26 | 0,18-0,35 | 0,14-0,26 |
| N   | Aluminium forging alloys                              | 180-280    | 0,04-0,06  | 0,07-0,12 | 0,08-0,13 | 0,09-0,15 | 0,12-0,20 | 0,08-0,13 | 0,09-0,15 |
|     | Aluminium cast alloys                                 | 120-270    | 0,04-0,06  | 0,06-0,12 | 0,08-0,13 | 0,09-0,15 | 0,12-0,20 | 0,08-0,13 | 0,09-0,15 |

## POWER REQUIREMENTS

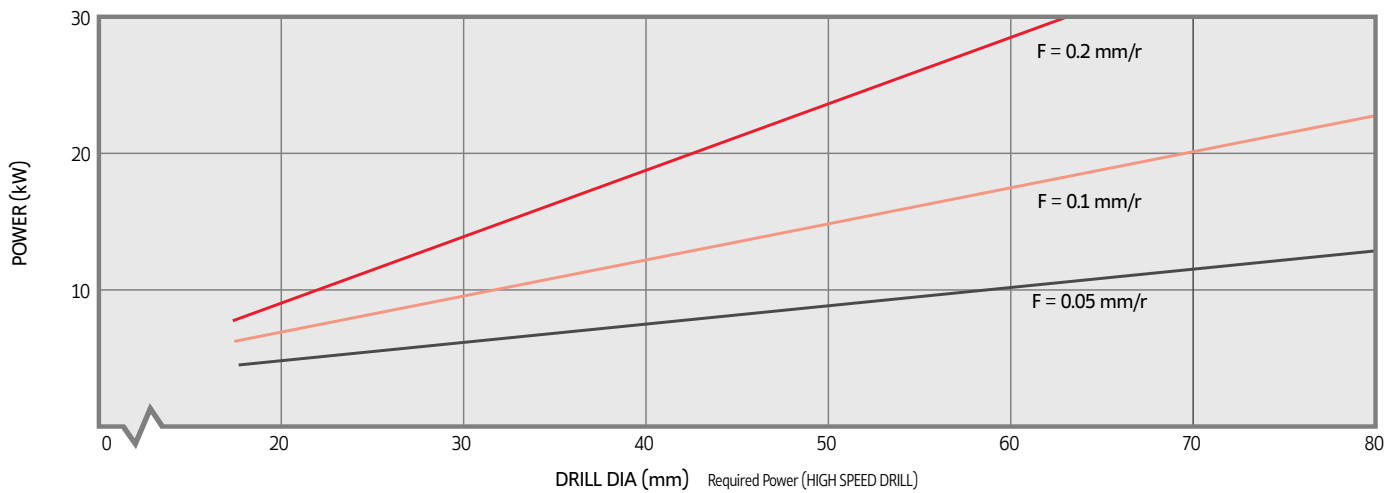

• These chart is based on machining experiences using steels with a hardness of 200-250HB and cutting speed of 100m/min.  
 • For cast iron the effective power requirement is around 30% lower.

## COOLANT APPLICATION CHART

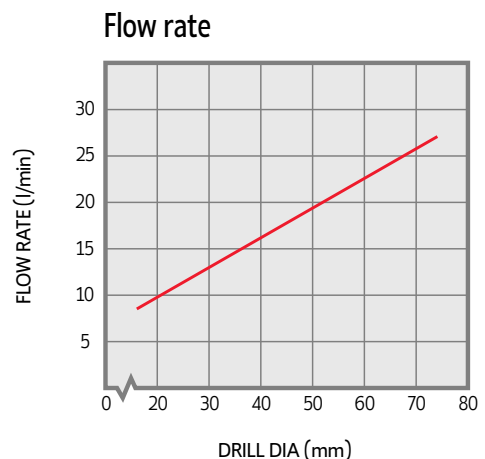
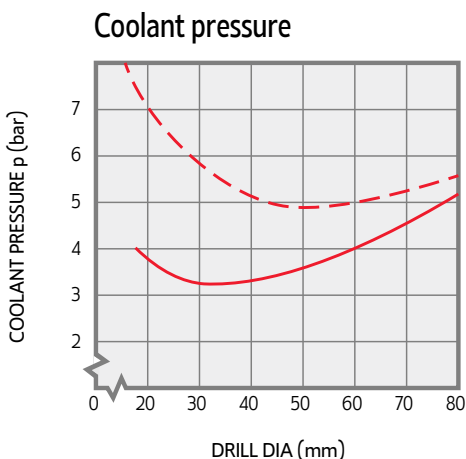

HOLE TOLERANCE AND MAXIMUM HOLE SIZE WITH RADIAL ADJUSTMENT

|                   | Drill D | Radial Adjust | Max Hole D |  | Drill D | Radial Adjust | Max Hole D |
|-------------------|---------|---------------|------------|--|---------|---------------|------------|
|                   | 13.00   | 1.50          | 16.00      |  | 33.00   | 3.00          | 39.00      |
| Multi cut         | 13.50   | 1.50          | 16.50      |  | 34.00   | 2.80          | 39.60      |
|                   | 14.00   | 1.50          | 17.00      |  | 35.00   | 2.50          | 40.00      |
|                   | 14.50   | 1.50          | 17.50      |  | 36.00   | 2.30          | 40.60      |
| Jet Drills        | 15.00   | 1.50          | 18.00      |  | 37.00   | 2.00          | 41.00      |
|                   | 15.50   | 1.50          | 18.50      |  | 38.00   | 1.80          | 41.60      |
|                   | 16.00   | 1.50          | 19.00      |  | 39.00   | 1.50          | 42.00      |
| Integrex Drills   | 16.50   | 1.50          | 19.50      |  | 40.00   | 1.20          | 42.40      |
|                   | 17.00   | 1.50          | 20.00      |  | 41.00   | 1.00          | 43.00      |
|                   | 17.50   | 1.50          | 20.50      |  | 42.00   | 4.20          | 50.40      |
|                   | 18.00   | 1.40          | 20.80      |  | 43.00   | 4.00          | 51.00      |
| Vortex Drills     | 18.50   | 1.30          | 21.10      |  | 44.00   | 3.70          | 51.40      |
|                   | 19.00   | 1.20          | 21.40      |  | 45.00   | 3.50          | 52.00      |
|                   | 20.00   | 1.00          | 22.00      |  | 46.00   | 3.30          | 52.60      |
|                   | 21.00   | 1.60          | 24.20      |  | 47.00   | 3.00          | 53.00      |
| Trepanning Drills | 22.00   | 1.50          | 25.00      |  | 48.00   | 2.70          | 53.40      |
|                   | 23.00   | 1.25          | 25.50      |  | 49.00   | 2.50          | 54.00      |
|                   | 24.00   | 1.00          | 26.00      |  | 50.00   | 2.20          | 54.40      |
| Inserts           | 25.00   | 0.80          | 26.60      |  | 51.00   | 2.00          | 55.00      |
|                   | 26.00   | 2.50          | 31.00      |  | 52.00   | 1.80          | 55.60      |
|                   | 27.00   | 2.20          | 31.40      |  | 53.00   | 1.50          | 56.00      |
| Spare Parts       | 28.00   | 2.10          | 32.20      |  | 54.00   | 1.20          | 56.40      |
|                   | 29.00   | 1.80          | 32.60      |  | 55.00   | 0.80          | 56.60      |
|                   | 30.00   | 1.50          | 33.00      |  | 56.00   | 0.60          | 57.20      |
| Technical Data    | 31.00   | 3.50          | 38.00      |  | 58.00   | 0.40          | 58.80      |
|                   | 32.00   | 3.20          | 38.40      |  |         |               |            |

## RECOMMENDED SPEEDS AND FEEDS

| ISO | Material Group<br>Grupo Materiais<br>Grupo Materiales | Vc<br>(m/min) | f (mm/rev) |            |           |           |           |           |           |           |           |
|-----|---|---------------|------------|------------|-----------|-----------|-----------|-----------|-----------|-----------|-----------|
|     |   |               | Ø12,5-15   | Ø15,5-21,5 | Ø22-27,5  | Ø28-33    | Ø34-41    | Ø42-50    | Ø50-60    | Ø60-75    | Ø75-80    |
| P   | Unalloyed steel (-0,25%)                              | 180-250       | 0,05-0,08  | 0,06-0,10  | 0,06-0,12 | 0,07-0,13 | 0,08-0,15 | 0,08-0,16 | 0,06-0,12 | 0,08-0,12 | 0,08-0,12 |
|     | Low-alloy steel (0,25%-)                              | 160-220       | 0,06-0,12  | 0,08-0,15  | 0,10-0,18 | 0,12-0,22 | 0,12-0,24 | 0,13-0,25 | 0,10-0,14 | 0,12-0,18 | 0,11-0,18 |
|     | Low-alloy steel                                       | 150-220       | 0,06-0,12  | 0,08-0,14  | 0,10-0,18 | 0,12-0,22 | 0,12-0,23 | 0,13-0,24 | 0,08-0,15 | 0,10-0,18 | 0,10-0,18 |
|     | High-alloy steel                                      | 130-180       | 0,06-0,10  | 0,08-0,15  | 0,10-0,20 | 0,12-0,23 | 0,12-0,24 | 0,13-0,25 | 0,08-0,14 | 0,09-0,15 | 0,09-0,14 |
| M   | Stainless steel                                       | 170-240       | 0,05-0,10  | 0,06-0,12  | 0,08-0,15 | 0,09-0,16 | 0,10-0,17 | 0,11-0,19 | 0,06-0,13 | 0,08-0,15 | 0,08-0,14 |
| K   | Grey cast iron  | 180-250       | 0,06-0,12  | 0,08-0,16  | 0,12-0,20 | 0,15-0,25 | 0,16-0,28 | 0,18-0,30 | 0,12-0,20 | 0,15-0,20 | 0,15-0,20 |
|     | Cast iron with nodular cast                           | 130-200       | 0,06-0,10  | 0,08-0,15  | 0,10-0,18 | 0,12-0,20 | 0,15-0,23 | 0,16-0,25 | 0,10-0,15 | 0,09-0,18 | 0,10-0,18 |

## POWER REQUIREMENTS

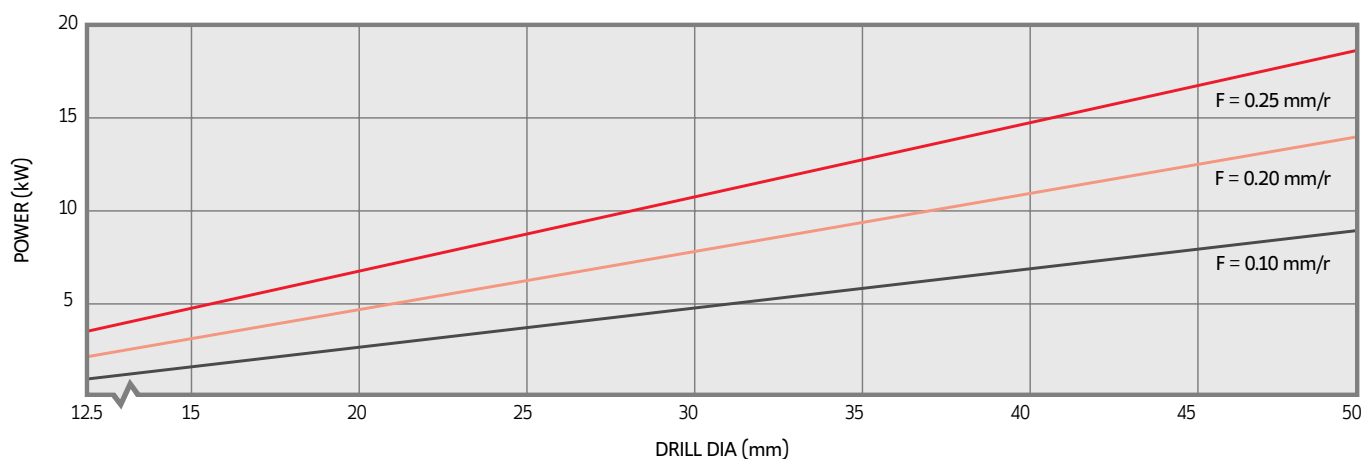

• These chart is based on machining experiences using steels with a hardness of 200-250HB and cutting speed of 100m/min.  
• For cast iron the effective power requirement is around 30% lower.

## COOLANT APPLICATION CHART

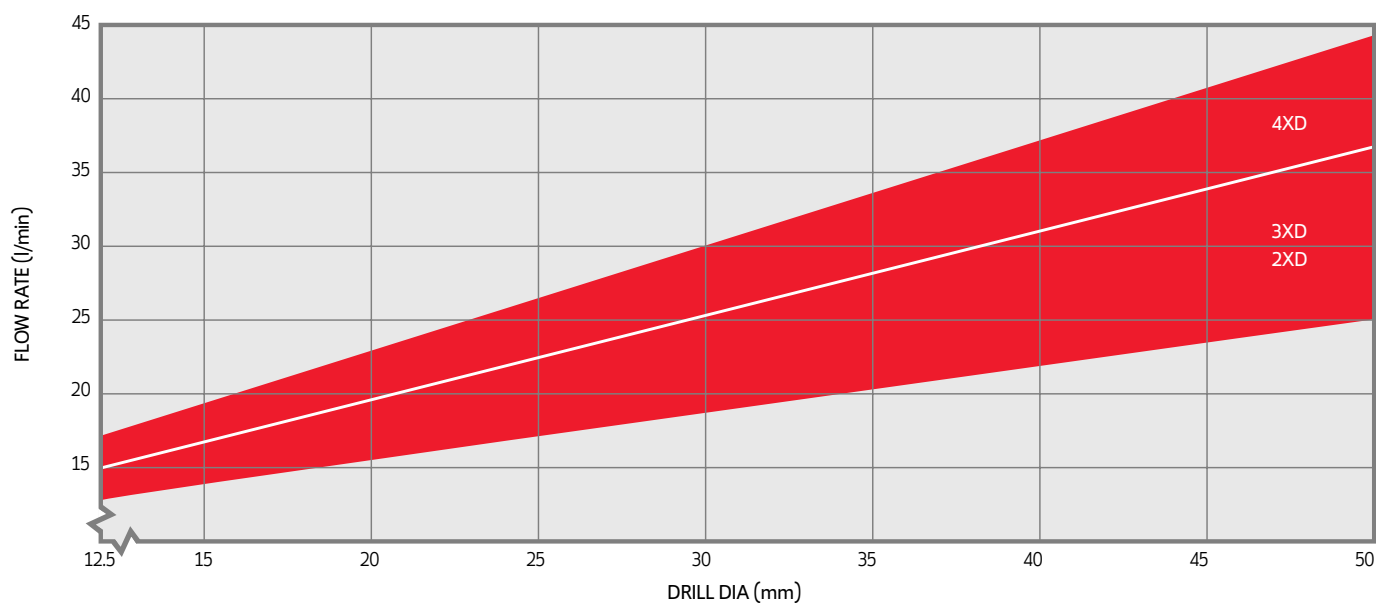

**HOLE TOLERANCE AND MAXIMUM HOLE SIZE WITH RADIAL ADJUSTMENT**

| Drill D | 3xD    |               |             |
|---------|--------|---------------|-------------|
|         | Normal | Radial Adjust | Max. Hole D |
| 13      | 13.16  | 0.50          | 14.0        |
| 14      | 14.10  | 0.50          | 15.0        |
| 15      | 15.10  | 0.50          | 16.0        |
| 16      | 16.07  | 0.50          | 17.0        |
| 17      | 17.08  | 0.50          | 18.0        |
| 18      | 18.05  | 0.50          | 19.0        |
| 19      | 19.08  | 0.50          | 20.0        |
| 20      | 20.06  | 0.50          | 21.0        |
| 21      | 20.97  | 0.25          | 21.5        |
| 22      | 21.94  | 0.50          | 23.0        |
| 23      | 23.10  | 0.50          | 24.0        |
| 24      | 24.10  | 0.50          | 25.0        |
| 25      | 25.06  | 0.50          | 26.0        |
| 26      | 26.03  | 0.25          | 26.5        |
| 27      | 27.05  | 0.25          | 27.5        |
| 28      | 28.11  | 0.50          | 29.0        |
| 29      | 28.54  | 0.50          | 30.0        |
| 30      | 30.23  | 0.50          | 31.0        |
| 31      | 31.07  | 0.25          | 31.5        |
| 32      | 32.06  | 0.25          | 32.5        |
| 33      | 33.12  | 0.25          | 33.5        |
| 34      | 34.10  | 0.50          | 35.0        |
| 35      | 35.07  | 0.50          | 36.0        |
| 36      | 36.03  | 0.50          | 37.0        |
| 37      | 37.14  | 0.50          | 38.0        |
| 38      | 38.05  | 0.50          | 39.0        |
| 39      | 39.03  | 0.50          | 40.0        |
| 40      | 40.00  | 0.25          | 40.5        |
| 41      | 40.99  | 0.25          | 41.5        |
| 42      | 42.03  | 0.50          | 43.0        |
| 43      | 42.99  | 0.50          | 44.0        |
| 44      | 44.17  | 0.50          | 45.0        |
| 45      | 45.21  | 0.50          | 46.0        |
| 46      | 46.17  | 0.50          | 47.0        |
| 47      | 47.15  | 0.50          | 48.0        |
| 48      | 48.12  | 0.25          | 48.5        |
| 49      | 49.00  | 0.25          | 49.5        |
| 50      | 50.02  | 0.25          | 50.5        |

| Drill D | 4xD    |               |             |
|---------|--------|---------------|-------------|
|         | Normal | Radial Adjust | Max. Hole D |
| 13      | 13.22  | 0.50          | 14.0        |
| 14      | 14.15  | 0.50          | 15.0        |
| 15      | 15.17  | 0.50          | 16.0        |
| 16      | 16.09  | 0.50          | 17.0        |
| 17      | 17.13  | 0.50          | 18.0        |
| 18      | 18.20  | 0.50          | 19.0        |
| 19      | 19.18  | 0.50          | 20.0        |
| 20      | 20.05  | 0.50          | 21.0        |
| 21      | 21.00  | 0.25          | 21.5        |
| 22      | 22.01  | 0.50          | 23.0        |
| 23      | 23.10  | 0.50          | 24.0        |
| 24      | 24.15  | 0.50          | 25.0        |
| 25      | 25.13  | 0.50          | 26.0        |
| 26      | 26.09  | 0.25          | 26.5        |
| 27      | 26.96  | 0.25          | 27.5        |
| 28      | 27.97  | 0.50          | 29.0        |
| 29      | 29.07  | 0.50          | 30.0        |
| 30      | 30.13  | 0.50          | 31.0        |
| 31      | 31.12  | 0.25          | 31.5        |
| 32      | 32.11  | 0.25          | 32.5        |
| 33      | 33.17  | 0.25          | 33.5        |
| 34      | 34.15  | 0.50          | 35.0        |
| 35      | 35.12  | 0.50          | 36.0        |
| 36      | 36.08  | 0.50          | 37.0        |
| 37      | 37.19  | 0.50          | 38.0        |
| 38      | 38.08  | 0.50          | 39.0        |
| 39      | 39.08  | 0.50          | 40.0        |
| 40      | 40.05  | 0.25          | 40.5        |
| 41      | 41.04  | 0.25          | 41.5        |
| 42      | 42.08  | 0.50          | 43.0        |
| 43      | 43.04  | 0.50          | 44.0        |
| 44      | 44.22  | 0.50          | 45.0        |
| 45      | 45.26  | 0.50          | 46.0        |
| 46      | 46.23  | 0.50          | 47.0        |
| 47      | 47.20  | 0.50          | 48.0        |
| 48      | 48.17  | 0.25          | 48.5        |
| 49      | 49.05  | 0.25          | 49.5        |
| 50      | 50.07  | 0.25          | 50.5        |

Multi cut

Jet Drills

Integrex Drills

Vortex Drills

Trepanning Drills

Inserts

Spare Parts

Technical Data

Solid Carbide Drills

## PILOT DRILL ADJUSTEMENT

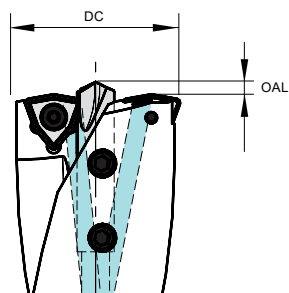

| DC    | OAL |
|-------|-----|
| 18-24 | 2,5 |
| 25-30 | 3,0 |
| 31-39 | 4,0 |
| 40-59 | 4,5 |
| 60-80 | 5,0 |

## RECOMMENDED SPEEDS AND FEEDS

| ISO | Material Group<br>Grupo Materiais<br>Grupo Materiales | V <sub>c</sub><br>(m/min) | f (mm/rev) |           |           |           |           |           |           |
|-----|---|---------------------------|------------|-----------|-----------|-----------|-----------|-----------|-----------|
|     |   |                           | Ø25        | Ø26-30    | Ø31-40    | Ø41-50    | Ø51-59    | Ø60-75    | Ø75-80    |
| P   | Unalloyed steel (-0,25%)                              | 130-190                   | 0,06-0,10  | 0,07-0,11 | 0,08-0,12 | 0,10-0,14 | 0,14-0,20 | 0,08-0,12 | 0,10-0,14 |
|     | Low-alloy steel (0,25%-)                              | 130-190                   | 0,06-0,10  | 0,07-0,11 | 0,08-0,12 | 0,10-0,14 | 0,12-0,18 | 0,08-0,12 | 0,10-0,14 |
|     | Low-alloy steel (-HB300)                              | 100-140                   | 0,06-0,10  | 0,07-0,11 | 0,08-0,12 | 0,10-0,14 | 0,12-0,18 | 0,08-0,12 | 0,10-0,14 |
|     | High-alloy steel (HB300-)                             | 60-100                    | 0,05-0,07  | 0,05-0,07 | 0,06-0,08 | 0,06-0,10 | 0,09-0,13 | 0,06-0,08 | 0,06-0,10 |
| M   | Stainless steel                                       | 60-110                    | 0,04-0,07  | 0,04-0,11 | 0,06-0,12 | 0,08-0,14 | 0,10-0,18 | 0,06-0,12 | 0,08-0,14 |
| K   | Grey cast iron  | 130-190                   | 0,07-0,13  | 0,07-0,15 | 0,08-0,16 | 0,10-0,18 | 0,12-0,22 | 0,08-0,16 | 0,10-0,18 |
|     | Cast iron with nodular cast                           | 110-190                   | 0,04-0,13  | 0,07-0,15 | 0,08-0,16 | 0,10-0,25 | 0,12-0,26 | 0,08-0,16 | 0,10-0,25 |

## POWER REQUIREMENTS

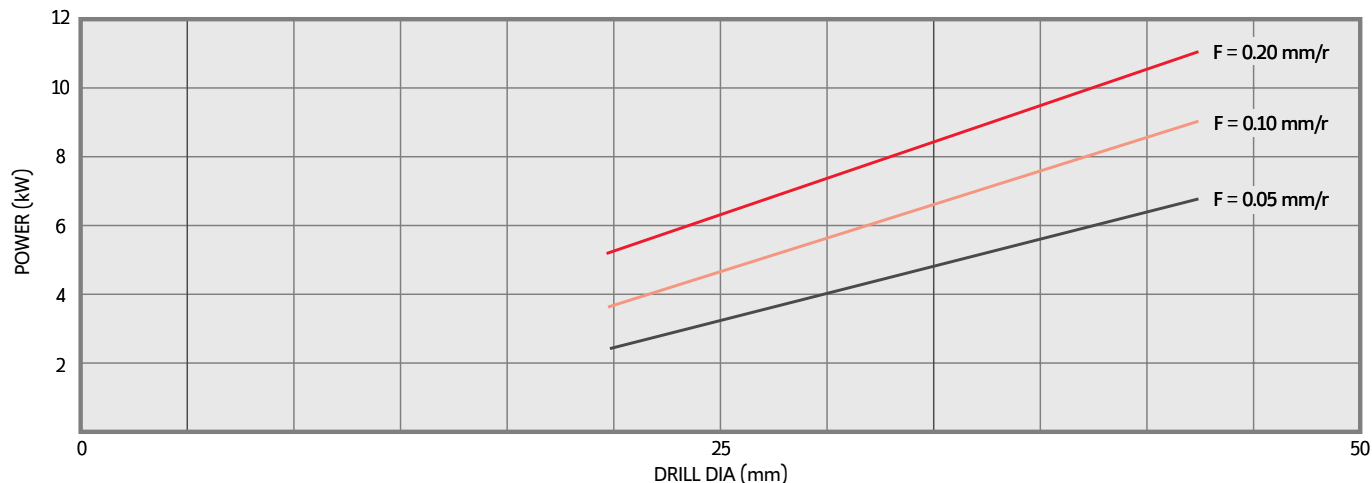

## COOLANT APPLICATION CHART

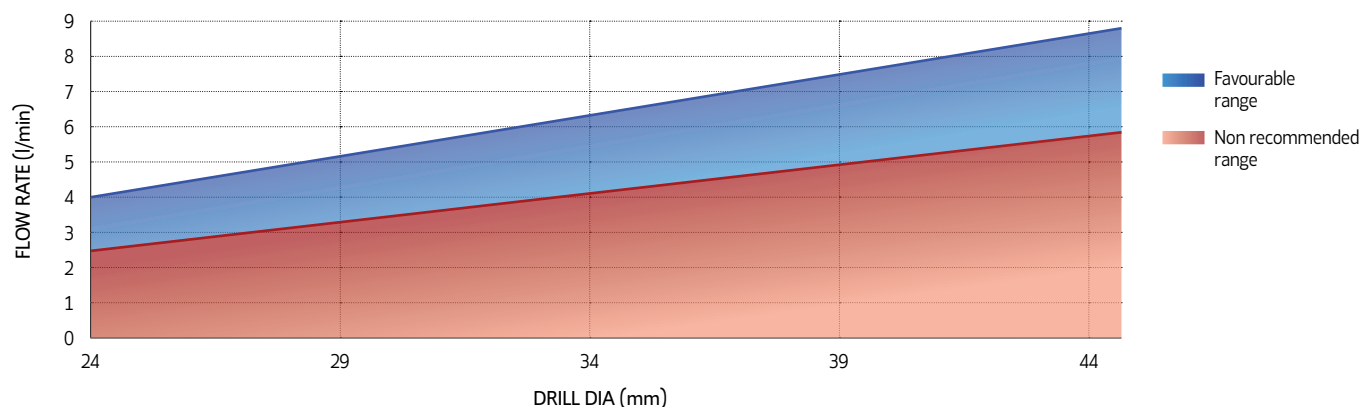

## PILOT DRILL ADJUSTEMENT

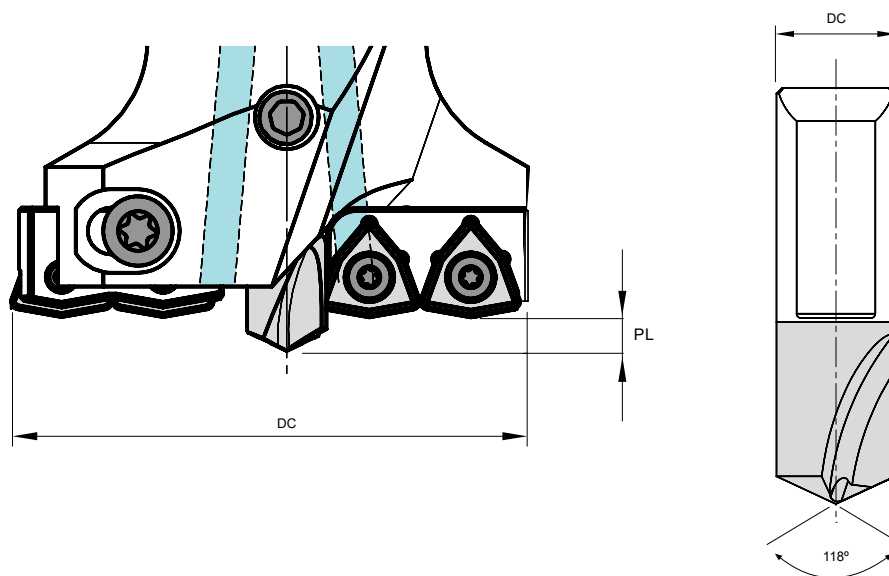

| DC (mm) | 2D to 4D | 4D to 6D | > 6D |
|---------|----------|----------|------|
|         | PL       | PL       | PL   |
| 45-55   | 4,0      | 4,2      | 4,4  |
| 55-75   | 5,4      | 5,6      | 5,8  |
| 75-100  | 6,5      | 6,8      | 7,1  |
| 100-120 | 7,7      | 8,1      | 8,5  |
| 120-170 | 9,9      | 10,3     | 10,7 |
| 170-180 | 12,2     | 12,6     | 13,0 |

## RECOMMENDED SPEEDS AND FEEDS

| ISO | Material Group<br>Grupo Materiais<br>Grupo Materiales | Vc<br>(m/min) | f (mm/rev) |           |           |           |           |           |           |
|-----|---|---------------|------------|-----------|-----------|-----------|-----------|-----------|-----------|
|     |   |               | Ø45-55     | Ø55-60    | Ø60-75    | Ø75-100   | Ø100-105  | Ø105-150  | Ø150-180  |
| P   | Unalloyed steel (-0,25%)                              | 120-180       | 0,06-0,10  | 0,07-0,11 | 0,08-0,12 | 0,10-0,14 | 0,14-0,20 | 0,08-0,12 | 0,10-0,14 |
|     | Low-alloy steel (0,25%-)                              | 110-170       | 0,06-0,10  | 0,07-0,11 | 0,08-0,12 | 0,10-0,14 | 0,12-0,18 | 0,08-0,12 | 0,10-0,14 |
|     | Low-alloy steel (-HB300)                              | 90-130        | 0,06-0,10  | 0,07-0,11 | 0,08-0,12 | 0,10-0,14 | 0,12-0,18 | 0,08-0,12 | 0,10-0,14 |
|     | High-alloy steel (HB300-)                             | 60-100        | 0,05-0,07  | 0,05-0,07 | 0,06-0,08 | 0,06-0,10 | 0,09-0,13 | 0,06-0,08 | 0,06-0,10 |
| M   | Stainless steel                                       | 60-110        | 0,04-0,07  | 0,04-0,11 | 0,06-0,12 | 0,08-0,14 | 0,10-0,18 | 0,06-0,12 | 0,08-0,14 |
| K   | Grey cast iron  | 120-180       | 0,07-0,13  | 0,07-0,15 | 0,08-0,16 | 0,10-0,18 | 0,12-0,22 | 0,08-0,16 | 0,10-0,18 |
|     | Cast iron with nodular cast                           | 100-180       | 0,04-0,13  | 0,07-0,15 | 0,08-0,16 | 0,10-0,25 | 0,12-0,26 | 0,08-0,16 | 0,10-0,25 |

## POWER REQUIREMENTS

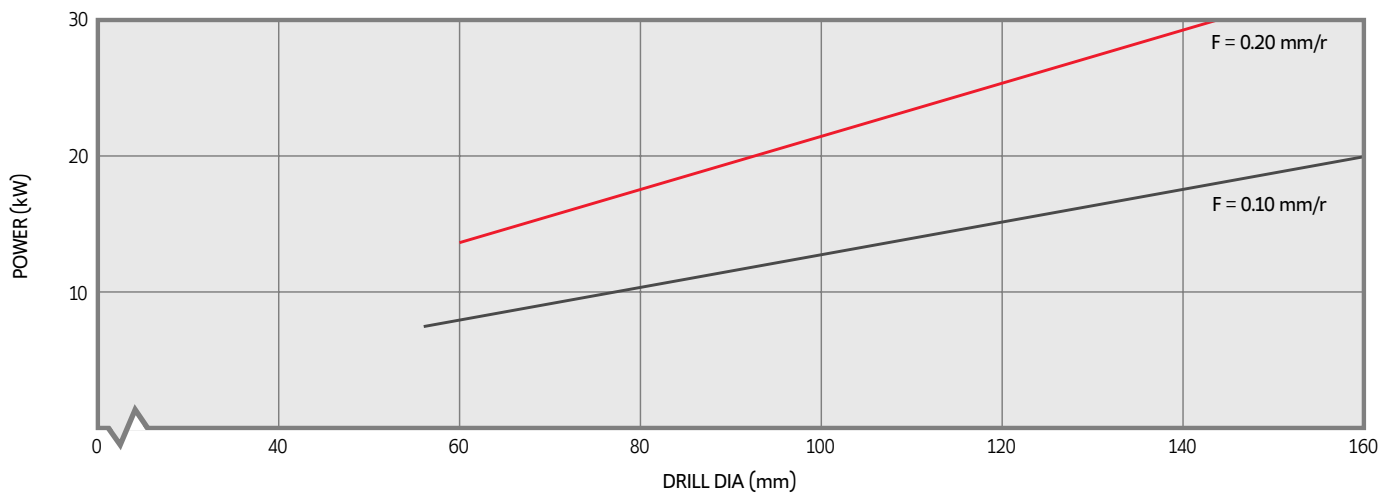

• These chart is based on machining experiences using steels with a hardness of 200-250HB and cutting speed of 100m/min.

## COOLANT APPLICATION CHART

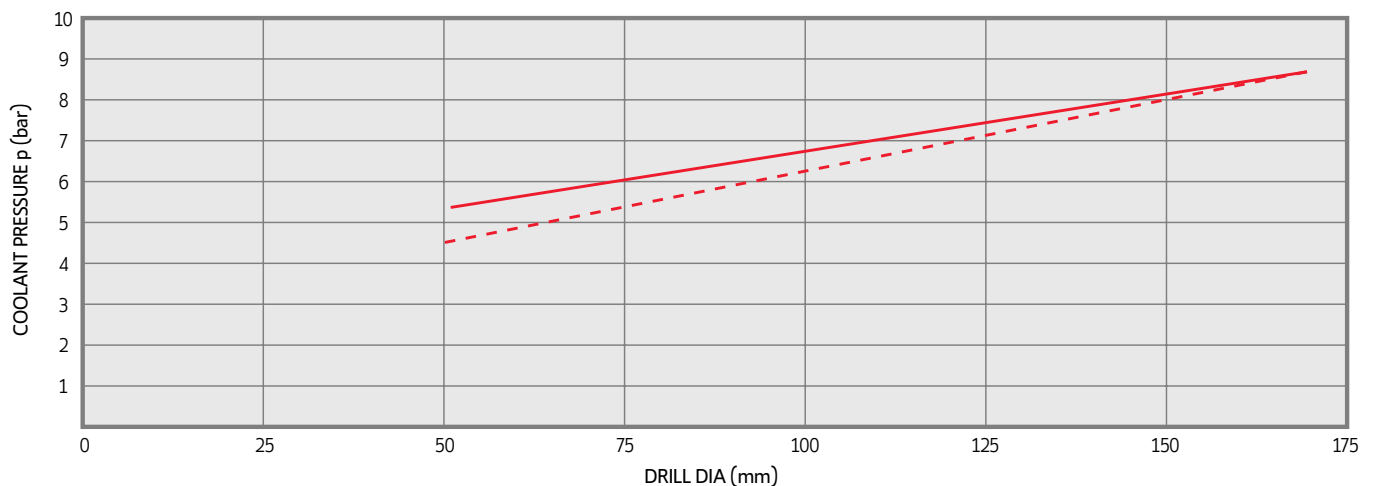

# SOLID CARBIDE

DRILLS



Solid carbide drills represent an excellent choice for ensuring excellent process security and achieving high-quality holes. They offer an optimal combination of feed rate and precision. This includes micro drills and optimized drills.

As brocas de metal duro representam uma excelente escolha para garantir segurança no processo e alcançar furos de alta qualidade. Oferecem uma combinação ideal de taxa de avanço e precisão. Inclui microbrocas e brocas otimizadas.

Las brocas de carburo sólido representan una excelente opción para garantizar seguridad del proceso y lograr orificios de alta calidad. Ofrecen una combinación óptima de velocidad de avance y precisión. Incluye microbrocas y brocas optimizadas.

## **NEW HMDUUE** > page 454

- > From DC 1,0mm to 2,9mm  
De DC 1,0mm a 2,9mm | Desde DC 1,0mm hasta 2,9mm
- > Available in 3D  
Disponível em 3D | Disponible en 3D
- > Without coolant  
Sem refrigeração | Sin refrigeración



## **NEW HMDUCE** > page 455

- > From DC 1,0mm to 2,9mm  
De DC 1,0mm a 2,9mm | Desde DC 1,0mm hasta 2,9mm
- > Available in 5D  
Disponível em 5D | Disponible en 5D
- > With coolant  
Com refrigeração | Con refrigeración



## **HBDPCE/W** > page 456

- > From DC 3,0mm to 20,0mm  
De DC 3,0mm a 20,0mm | Desde DC 3,0mm hasta 20,0mm
- > Available in 3D, 5D and 8D  
Disponível em 3D, 5D e 8D | Disponible en 3D, 5D y 8D
- > With coolant  
Com refrigeração | Con refrigeración



## **HBDPUE/W** > page 465

- > From DC 3,0mm to 20,0mm  
De DC 3,0mm a 20,0mm | Desde DC 3,0mm hasta 20,0mm
- > Available in 3D and 5D  
Disponível em 3D e 5D | Disponible en 3D y 5D
- > Without coolant  
Sem refrigeração | Sin refrigeración

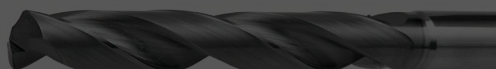



|                |                   |
|----------------|-------------------|
| P              | K                 |
| HRC<br>≤<br>60 | IT8-9<br>IT class |

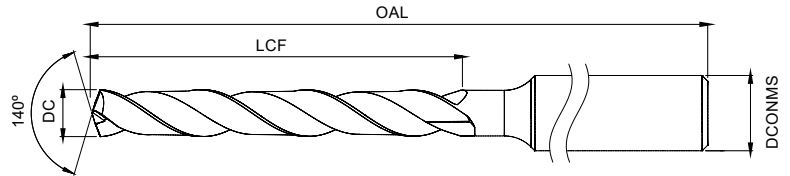

| Order code | Reference<br>Referência<br>Referencia | Dimensions   Dimensões   Dimensiones (mm) |        |     |     | NOF | Stock<br>PHU920  |
|------------|---------------------------------------|---|--------|-----|-----|-----|------------------|
|            |                                       | DC  | DCONMS | LCF | OAL |     | HA (Cylindrical) |
| 1182306Z9  | HMDUUE 2 03D 0100-045005              | 1,00                                      | 4      | 5   | 45  | 2   | ☉                |
| 1181797Z9  | HMDUUE 2 03D 0110-045007              | 1,10                                      | 4      | 7   | 45  | 2   | ☉                |
| 1181798Z9  | HMDUUE 2 03D 0120-045007              | 1,20                                      | 4      | 7   | 45  | 2   | ☉                |
| 1181799Z9  | HMDUUE 2 03D 0130-045007              | 1,30                                      | 4      | 7   | 45  | 2   | ☉                |
| 1181800Z9  | HMDUUE 2 03D 0140-045007              | 1,40                                      | 4      | 7   | 45  | 2   | ☉                |
| 1181801Z9  | HMDUUE 2 03D 0150-045007              | 1,50                                      | 4      | 7   | 45  | 2   | ☉                |
| 1181802Z9  | HMDUUE 2 03D 0160-055014              | 1,60                                      | 4      | 14  | 55  | 2   | ☉                |
| 1181803Z9  | HMDUUE 2 03D 0170-055014              | 1,70                                      | 4      | 14  | 55  | 2   | ☉                |
| 1181804Z9  | HMDUUE 2 03D 0180-055014              | 1,80                                      | 4      | 14  | 55  | 2   | ☉                |
| 1181814Z9  | HMDUUE 2 03D 0190-055014              | 1,90                                      | 4      | 14  | 55  | 2   | ☉                |
| 1181501Z9  | HMDUUE 2 03D 0200-055020              | 2,00                                      | 4      | 20  | 55  | 2   | ☉                |
| 1182307Z9  | HMDUUE 2 03D 0210-055020              | 2,10                                      | 4      | 20  | 55  | 2   | ☉                |
| 1181817Z9  | HMDUUE 2 03D 0220-055020              | 2,20                                      | 4      | 20  | 55  | 2   | ☉                |
| 1181818Z9  | HMDUUE 2 03D 0230-055020              | 2,30                                      | 4      | 20  | 55  | 2   | ☉                |
| 1181819Z9  | HMDUUE 2 03D 0240-055020              | 2,40                                      | 4      | 20  | 55  | 2   | ☉                |
| 1182308Z9  | HMDUUE 2 03D 0250-055020              | 2,50                                      | 4      | 20  | 55  | 2   | ☉                |
| 1181821Z9  | HMDUUE 2 03D 0260-055020              | 2,60                                      | 4      | 20  | 55  | 2   | ☉                |
| 1181822Z9  | HMDUUE 2 03D 0270-055020              | 2,70                                      | 4      | 20  | 55  | 2   | ☉                |
| 1182309Z9  | HMDUUE 2 03D 0280-055020              | 2,80                                      | 4      | 20  | 55  | 2   | ☉                |
| 1182310Z9  | HMDUUE 2 03D 0290-055020              | 2,90                                      | 4      | 20  | 55  | 2   | ☉                |

☉ Stock item | Produto de stock | Itens de stock

○ Available under request | Disponível sobre consulta | Disponible bajo consulta

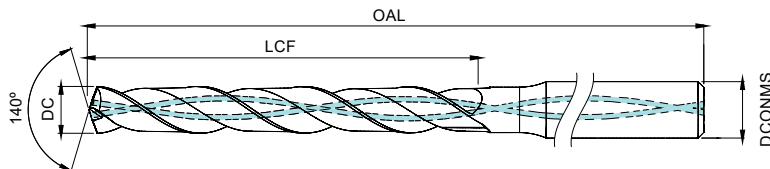

|                |                   |
|----------------|-------------------|
| P              | K                 |
| HRC<br>≤<br>60 | IT8-9<br>IT class |

| Order code | Reference<br>Referência<br>Referencia | Dimensions   Dimensões   Dimensiones (mm) |        |     |     | NOF | Stock<br>PHU920  |
|------------|---------------------------------------|---|--------|-----|-----|-----|------------------|
|            |                                       | DC  | DCONMS | LCF | OAL |     | HA (Cylindrical) |
| 1181838Z9  | HMDUCE 2 05D 0100-055010              | 1,00                                      | 3      | 10  | 55  | 2   | ⊗                |
| 1181839Z9  | HMDUCE 2 05D 0110-055012              | 1,10                                      | 3      | 12  | 55  | 2   | ⊗                |
| 1181840Z9  | HMDUCE 2 05D 0120-055012              | 1,20                                      | 3      | 12  | 55  | 2   | ⊗                |
| 1181841Z9  | HMDUCE 2 05D 0130-055012              | 1,30                                      | 3      | 12  | 55  | 2   | ⊗                |
| 1181842Z9  | HMDUCE 2 05D 0140-055012              | 1,40                                      | 3      | 12  | 55  | 2   | ⊗                |
| 1181843Z9  | HMDUCE 2 05D 0150-055012              | 1,50                                      | 3      | 12  | 55  | 2   | ⊗                |
| 1181844Z9  | HMDUCE 2 05D 0160-055016              | 1,60                                      | 3      | 16  | 55  | 2   | ⊗                |
| 1181845Z9  | HMDUCE 2 05D 0170-055016              | 1,70                                      | 3      | 16  | 55  | 2   | ⊗                |
| 1181846Z9  | HMDUCE 2 05D 0180-055016              | 1,80                                      | 3      | 16  | 55  | 2   | ⊗                |
| 1181847Z9  | HMDUCE 2 05D 0190-055016              | 1,90                                      | 3      | 16  | 55  | 2   | ⊗                |
| 1181848Z9  | HMDUCE 2 05D 0200-055016              | 2,00                                      | 3      | 16  | 55  | 2   | ⊗                |
| 1181849Z9  | HMDUCE 2 05D 0210-055021              | 2,10                                      | 3      | 21  | 55  | 2   | ⊗                |
| 1181850Z9  | HMDUCE 2 05D 0220-055021              | 2,20                                      | 3      | 21  | 55  | 2   | ⊗                |
| 1182311Z9  | HMDUCE 2 05D 0230-055021              | 2,30                                      | 3      | 21  | 55  | 2   | ⊗                |
| 1182312Z9  | HMDUCE 2 05D 0240-055021              | 2,40                                      | 3      | 21  | 55  | 2   | ⊗                |
| 1182313Z9  | HMDUCE 2 05D 0250-055021              | 2,50                                      | 3      | 21  | 55  | 2   | ⊗                |
| 1182314Z9  | HMDUCE 2 05D 0260-055021              | 2,60                                      | 3      | 21  | 55  | 2   | ⊗                |
| 1181855Z9  | HMDUCE 2 05D 0270-055021              | 2,70                                      | 3      | 21  | 55  | 2   | ⊗                |
| 1182315Z9  | HMDUCE 2 05D 0280-055021              | 2,80                                      | 3      | 21  | 55  | 2   | ⊗                |
| 1182316Z9  | HMDUCE 2 05D 0290-055021              | 2,90                                      | 3      | 21  | 55  | 2   | ⊗                |

⊗ Stock item | Produto de stock | Itens de stock

○ Available under request | Disponível sobre consulta | Disponible bajo consulta

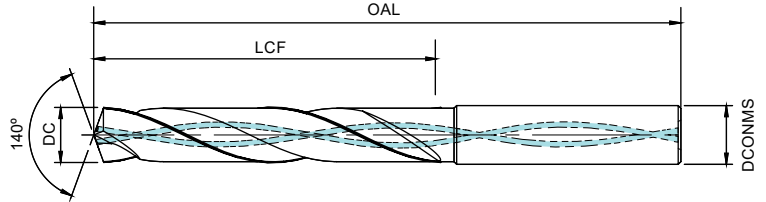

|                |                   |
|----------------|-------------------|
| P              | K                 |
| HRC<br>≤<br>60 | IT8-9<br>IT class |

| Drill Dia. DC   | DC3,0  | 3,0<DC≤6,0 | 6,0<DC≤10,0 | 10,0<DC≤18,0 | 18,0<DC≤20,0 |
|-----------------|--------|------------|-------------|--------------|--------------|
| Hole Tolerances | +0,002 | +0,004     | +0,006      | +0,007       | +0,008       |
|                 | +0,012 | +0,016     | +0,021      | +0,025       | +0,028       |

| Order code       |             | Reference<br>Referência<br>Referencia | Dimensions   Dimensões   Dimensiones (mm) |        |     |     | NOF | Stock<br>PHU920 |    |
|------------------|-------------|---------------------------------------|---|--------|-----|-----|-----|-----------------|----|
| HA (Cylindrical) | HB (Weldon) |                                       | DC  | DCONMS | LCF | OAL |     | HA              | HB |
| 1180956Z9        | 1181963Z9   | HBDPCE/W 2 03D 0300-062020            | 3,00                                      | 6      | 20  | 62  | 2   | ☺               | ☺  |
| 1180957Z9        | 1181964Z9   | HBDPCE/W 2 03D 0310-062020            | 3,10                                      | 6      | 20  | 62  | 2   | ☺               | ☺  |
| 1180958Z9        | 1181965Z9   | HBDPCE/W 2 03D 0320-062020            | 3,20                                      | 6      | 20  | 62  | 2   | ☺               | ☺  |
| 1181791Z9        | 1181966Z9   | HBDPCE/W 2 03D 0325-062020            | 3,25                                      | 6      | 20  | 62  | 2   | ☺               | ○  |
| 1180959Z9        | 1181967Z9   | HBDPCE/W 2 03D 0330-062020            | 3,30                                      | 6      | 20  | 62  | 2   | ☺               | ☺  |
| 1180960Z9        | 1181968Z9   | HBDPCE/W 2 03D 0340-062020            | 3,40                                      | 6      | 20  | 62  | 2   | ☺               | ○  |
| 1180961Z9        | 1181969Z9   | HBDPCE/W 2 03D 0350-062020            | 3,50                                      | 6      | 20  | 62  | 2   | ☺               | ☺  |
| 1180962Z9        | 1181970Z9   | HBDPCE/W 2 03D 0360-062020            | 3,60                                      | 6      | 20  | 62  | 2   | ☺               | ☺  |
| 1180963Z9        | 1181971Z9   | HBDPCE/W 2 03D 0370-062020            | 3,70                                      | 6      | 20  | 62  | 2   | ☺               | ○  |
| 1180964Z9        | 1181972Z9   | HBDPCE/W 2 03D 0380-066024            | 3,80                                      | 6      | 24  | 66  | 2   | ☺               | ○  |
| 1180965Z9        | 1181973Z9   | HBDPCE/W 2 03D 0390-066024            | 3,90                                      | 6      | 24  | 66  | 2   | ☺               | ☺  |
| 1180966Z9        | 1181974Z9   | HBDPCE/W 2 03D 0400-066024            | 4,00                                      | 6      | 24  | 66  | 2   | ☺               | ○  |
| 1180967Z9        | 1181975Z9   | HBDPCE/W 2 03D 0410-066024            | 4,10                                      | 6      | 24  | 66  | 2   | ☺               | ☺  |
| 1180968Z9        | 1181976Z9   | HBDPCE/W 2 03D 0420-066024            | 4,20                                      | 6      | 24  | 66  | 2   | ☺               | ☺  |
| 1180969Z9        | 1181977Z9   | HBDPCE/W 2 03D 0430-066024            | 4,30                                      | 6      | 24  | 66  | 2   | ☺               | ☺  |
| 1180970Z9        | 1181978Z9   | HBDPCE/W 2 03D 0440-066024            | 4,40                                      | 6      | 24  | 66  | 2   | ☺               | ☺  |
| 1180971Z9        | 1181979Z9   | HBDPCE/W 2 03D 0450-066024            | 4,50                                      | 6      | 24  | 66  | 2   | ☺               | ○  |
| 1180972Z9        | 1181980Z9   | HBDPCE/W 2 03D 0460-066024            | 4,60                                      | 6      | 24  | 66  | 2   | ☺               | ○  |
| 1181793Z9        | 1181981Z9   | HBDPCE/W 2 03D 0465-066024            | 4,65                                      | 6      | 24  | 66  | 2   | ☺               | ○  |
| 1180973Z9        | 1181982Z9   | HBDPCE/W 2 03D 0470-066024            | 4,70                                      | 6      | 24  | 66  | 2   | ☺               | ☺  |
| 1180974Z9        | 1181983Z9   | HBDPCE/W 2 03D 0480-066028            | 4,80                                      | 6      | 28  | 66  | 2   | ☺               | ○  |
| 1180975Z9        | 1181984Z9   | HBDPCE/W 2 03D 0490-066028            | 4,90                                      | 6      | 28  | 66  | 2   | ☺               | ☺  |
| 1180976Z9        | 1181985Z9   | HBDPCE/W 2 03D 0500-066028            | 5,00                                      | 6      | 28  | 66  | 2   | ☺               | ○  |
| 1180977Z9        | 1181986Z9   | HBDPCE/W 2 03D 0510-066028            | 5,10                                      | 6      | 28  | 66  | 2   | ☺               | ○  |
| 1180978Z9        | 1181987Z9   | HBDPCE/W 2 03D 0520-066028            | 5,20                                      | 6      | 28  | 66  | 2   | ☺               | ○  |
| 1180979Z9        | 1181988Z9   | HBDPCE/W 2 03D 0530-066028            | 5,30                                      | 6      | 28  | 66  | 2   | ☺               | ☺  |

☺ Stock item | Produto de stock | Itens de stock

○ Available under request | Disponível sobre consulta | Disponible bajo consulta

Continue next page

# HBDPCE/W 2 03D

Solid carbide drills | Brocas de metal duro | Brocas en metal duro

| Order code       |             | Reference<br>Referência<br>Referencia | Dimensions   Dimensões   Dimensiones (mm) |        |     |     | NOF | Stock<br>PHU920 |    |
|------------------|-------------|---------------------------------------|---|--------|-----|-----|-----|-----------------|----|
| HA (Cylindrical) | HB (Weldon) |                                       | DC  | DCONMS | LCF | OAL |     | HA              | HB |
| 1180980Z9        | 1181989Z9   | HBDPCE/W 2 03D 0540-066028            | 5,40                                      | 6      | 28  | 66  | 2   | ⊗               | ⊗  |
| 1180981Z9        | 1181990Z9   | HBDPCE/W 2 03D 0550-066028            | 5,50                                      | 6      | 28  | 66  | 2   | ⊗               | ○  |
| 1181795Z9        | 1181991Z9   | HBDPCE/W 2 03D 0555-066028            | 5,55                                      | 6      | 28  | 66  | 2   | ⊗               | ⊗  |
| 1180982Z9        | 1181992Z9   | HBDPCE/W 2 03D 0560-066028            | 5,60                                      | 6      | 28  | 66  | 2   | ⊗               | ○  |
| 1180983Z9        | 1181993Z9   | HBDPCE/W 2 03D 0570-066028            | 5,70                                      | 6      | 28  | 66  | 2   | ⊗               | ⊗  |
| 1180984Z9        | 1181994Z9   | HBDPCE/W 2 03D 0580-066028            | 5,80                                      | 6      | 28  | 66  | 2   | ⊗               | ○  |
| 1180985Z9        | 1181995Z9   | HBDPCE/W 2 03D 0590-066028            | 5,90                                      | 6      | 28  | 66  | 2   | ⊗               | ⊗  |
| 1180986Z9        | 1181996Z9   | HBDPCE/W 2 03D 0600-066028            | 6,00                                      | 6      | 28  | 66  | 2   | ⊗               | ○  |
| 1180987Z9        | 1181997Z9   | HBDPCE/W 2 03D 0610-079034            | 6,10                                      | 8      | 34  | 79  | 2   | ⊗               | ○  |
| 1180988Z9        | 1181998Z9   | HBDPCE/W 2 03D 0620-079034            | 6,20                                      | 8      | 34  | 79  | 2   | ⊗               | ⊗  |
| 1180989Z9        | 1181999Z9   | HBDPCE/W 2 03D 0630-079034            | 6,30                                      | 8      | 34  | 79  | 2   | ⊗               | ⊗  |
| 1180990Z9        | 1182000Z9   | HBDPCE/W 2 03D 0640-079034            | 6,40                                      | 8      | 34  | 79  | 2   | ⊗               | ⊗  |
| 1180991Z9        | 1182001Z9   | HBDPCE/W 2 03D 0650-079034            | 6,50                                      | 8      | 34  | 79  | 2   | ⊗               | ○  |
| 1180792Z9        | 1182002Z9   | HBDPCE/W 2 03D 0660-079034            | 6,60                                      | 8      | 34  | 79  | 2   | ⊗               | ⊗  |
| 1180992Z9        | 1182003Z9   | HBDPCE/W 2 03D 0670-079034            | 6,70                                      | 8      | 34  | 79  | 2   | ⊗               | ⊗  |
| 1180993Z9        | 1182004Z9   | HBDPCE/W 2 03D 0680-079034            | 6,80                                      | 8      | 34  | 79  | 2   | ⊗               | ⊗  |
| 1180994Z9        | 1182005Z9   | HBDPCE/W 2 03D 0690-079034            | 6,90                                      | 8      | 34  | 79  | 2   | ⊗               | ⊗  |
| 1180995Z9        | 1182006Z9   | HBDPCE/W 2 03D 0700-079034            | 7,00                                      | 8      | 34  | 79  | 2   | ⊗               | ⊗  |
| 1180996Z9        | 1182007Z9   | HBDPCE/W 2 03D 0710-079041            | 7,10                                      | 8      | 41  | 79  | 2   | ⊗               | ⊗  |
| 1180997Z9        | 1182008Z9   | HBDPCE/W 2 03D 0720-079041            | 7,20                                      | 8      | 41  | 79  | 2   | ⊗               | ⊗  |
| 1180998Z9        | 1182009Z9   | HBDPCE/W 2 03D 0730-079041            | 7,30                                      | 8      | 41  | 79  | 2   | ⊗               | ⊗  |
| 1180999Z9        | 1182010Z9   | HBDPCE/W 2 03D 0740-079041            | 7,40                                      | 8      | 41  | 79  | 2   | ⊗               | ⊗  |
| 1181000Z9        | 1182011Z9   | HBDPCE/W 2 03D 0750-079041            | 7,50                                      | 8      | 41  | 79  | 2   | ⊗               | ⊗  |
| 1181001Z9        | 1182012Z9   | HBDPCE/W 2 03D 0760-079041            | 7,60                                      | 8      | 41  | 79  | 2   | ⊗               | ⊗  |
| 1181002Z9        | 1182013Z9   | HBDPCE/W 2 03D 0770-079041            | 7,70                                      | 8      | 41  | 79  | 2   | ⊗               | ⊗  |
| 1181003Z9        | 1182014Z9   | HBDPCE/W 2 03D 0780-079041            | 7,80                                      | 8      | 41  | 79  | 2   | ⊗               | ⊗  |
| 1181004Z9        | 1182015Z9   | HBDPCE/W 2 03D 0790-079041            | 7,90                                      | 8      | 41  | 79  | 2   | ⊗               | ○  |
| 1181005Z9        | 1182016Z9   | HBDPCE/W 2 03D 0800-079041            | 8,00                                      | 8      | 41  | 79  | 2   | ⊗               | ○  |
| 1181006Z9        | 1182017Z9   | HBDPCE/W 2 03D 0810-089047            | 8,10                                      | 10     | 47  | 89  | 2   | ⊗               | ⊗  |
| 1181007Z9        | 1182018Z9   | HBDPCE/W 2 03D 0820-089047            | 8,20                                      | 10     | 47  | 89  | 2   | ⊗               | ○  |
| 1181008Z9        | 1182019Z9   | HBDPCE/W 2 03D 0830-089047            | 8,30                                      | 10     | 47  | 89  | 2   | ⊗               | ⊗  |
| 1181009Z9        | 1182020Z9   | HBDPCE/W 2 03D 0840-089047            | 8,40                                      | 10     | 47  | 89  | 2   | ⊗               | ⊗  |
| 1181010Z9        | 1182021Z9   | HBDPCE/W 2 03D 0850-089047            | 8,50                                      | 10     | 47  | 89  | 2   | ⊗               | ○  |
| 1181011Z9        | 1182022Z9   | HBDPCE/W 2 03D 0860-089047            | 8,60                                      | 10     | 47  | 89  | 2   | ⊗               | ○  |
| 1181012Z9        | 1182023Z9   | HBDPCE/W 2 03D 0870-089047            | 8,70                                      | 10     | 47  | 89  | 2   | ⊗               | ⊗  |
| 1181013Z9        | 1182024Z9   | HBDPCE/W 2 03D 0880-089047            | 8,80                                      | 10     | 47  | 89  | 2   | ⊗               | ⊗  |
| 1181014Z9        | 1182025Z9   | HBDPCE/W 2 03D 0890-089047            | 8,90                                      | 10     | 47  | 89  | 2   | ⊗               | ⊗  |
| 1181015Z9        | 1182026Z9   | HBDPCE/W 2 03D 0900-089047            | 9,00                                      | 10     | 47  | 89  | 2   | ⊗               | ⊗  |
| 1181016Z9        | 1182027Z9   | HBDPCE/W 2 03D 0910-089047            | 9,10                                      | 10     | 47  | 89  | 2   | ⊗               | ○  |
| 1181017Z9        | 1182028Z9   | HBDPCE/W 2 03D 0920-089047            | 9,20                                      | 10     | 47  | 89  | 2   | ⊗               | ⊗  |
| 1181018Z9        | 1182029Z9   | HBDPCE/W 2 03D 0930-089047            | 9,30                                      | 10     | 47  | 89  | 2   | ⊗               | ○  |
| 1181019Z9        | 1182030Z9   | HBDPCE/W 2 03D 0940-089047            | 9,40                                      | 10     | 47  | 89  | 2   | ⊗               | ⊗  |
| 1181020Z9        | 1182031Z9   | HBDPCE/W 2 03D 0950-089047            | 9,50                                      | 10     | 47  | 89  | 2   | ⊗               | ⊗  |
| 1181021Z9        | 1182032Z9   | HBDPCE/W 2 03D 0960-089047            | 9,60                                      | 10     | 47  | 89  | 2   | ⊗               | ⊗  |
| 1181022Z9        | 1182033Z9   | HBDPCE/W 2 03D 0970-089047            | 9,70                                      | 10     | 47  | 89  | 2   | ⊗               | ⊗  |
| 1181023Z9        | 1182034Z9   | HBDPCE/W 2 03D 0980-089047            | 9,80                                      | 10     | 47  | 89  | 2   | ⊗               | ○  |

⊗ Stock item | Produto de stock | Itens de stock

○ Available under request | Disponível sobre consulta | Disponible bajo consulta

Continue next page

| Order code       |             | Reference<br>Referência<br>Referencia | Dimensions   Dimensões   Dimensiones (mm) |        |     |     | NOF | Stock<br>PHU920 |    |
|------------------|-------------|---------------------------------------|---|--------|-----|-----|-----|-----------------|----|
| HA (Cylindrical) | HB (Weldon) |                                       | DC  | DCONMS | LCF | OAL |     | HA              | HB |
| 1181024Z9        | 1182035Z9   | HBDPCE/W 2 03D 0990-089047            | 9,90                                      | 10     | 47  | 89  | 2   | ⊗               | ⊗  |
| 1181025Z9        | 1182036Z9   | HBDPCE/W 2 03D 1000-089047            | 10,00                                     | 10     | 47  | 89  | 2   | ⊗               | ○  |
| 1181026Z9        | -           | HBDPCE/W 2 03D 1010-102055            | 10,10                                     | 12     | 55  | 102 | 2   | ⊗               | -  |
| 1181027Z9        | 1182037Z9   | HBDPCE/W 2 03D 1020-102055            | 10,20                                     | 12     | 55  | 102 | 2   | ⊗               | ⊗  |
| 1181028Z9        | 1182038Z9   | HBDPCE/W 2 03D 1030-102055            | 10,30                                     | 12     | 55  | 102 | 2   | ⊗               | ⊗  |
| 1181029Z9        | -           | HBDPCE/W 2 03D 1040-102055            | 10,40                                     | 12     | 55  | 102 | 2   | ⊗               | -  |
| 1181030Z9        | 1182039Z9   | HBDPCE/W 2 03D 1050-102055            | 10,50                                     | 12     | 55  | 102 | 2   | ○               | ○  |
| 1181031Z9        | -           | HBDPCE/W 2 03D 1060-102055            | 10,60                                     | 12     | 55  | 102 | 2   | ⊗               | -  |
| 1181032Z9        | -           | HBDPCE/W 2 03D 1070-102055            | 10,70                                     | 12     | 55  | 102 | 2   | ○               | -  |
| 1181033Z9        | 1182040Z9   | HBDPCE/W 2 03D 1080-102055            | 10,80                                     | 12     | 55  | 102 | 2   | ○               | ⊗  |
| 1181034Z9        | -           | HBDPCE/W 2 03D 1090-102055            | 10,90                                     | 12     | 55  | 102 | 2   | ⊗               | -  |
| 1181035Z9        | 1182041Z9   | HBDPCE/W 2 03D 1100-102055            | 11,00                                     | 12     | 55  | 102 | 2   | ○               | ○  |
| 1181036Z9        | -           | HBDPCE/W 2 03D 1110-102055            | 11,10                                     | 12     | 55  | 102 | 2   | ⊗               | -  |
| 1181037Z9        | 1182042Z9   | HBDPCE/W 2 03D 1120-102055            | 11,20                                     | 12     | 55  | 102 | 2   | ○               | ⊗  |
| 1181038Z9        | -           | HBDPCE/W 2 03D 1130-102055            | 11,30                                     | 12     | 55  | 102 | 2   | ⊗               | -  |
| 1181039Z9        | -           | HBDPCE/W 2 03D 1140-102055            | 11,40                                     | 12     | 55  | 102 | 2   | ○               | -  |
| 1181040Z9        | 1182043Z9   | HBDPCE/W 2 03D 1150-102055            | 11,50                                     | 12     | 55  | 102 | 2   | ⊗               | ⊗  |
| 1181041Z9        | -           | HBDPCE/W 2 03D 1160-102055            | 11,60                                     | 12     | 55  | 102 | 2   | ○               | -  |
| 1181042Z9        | -           | HBDPCE/W 2 03D 1170-102055            | 11,70                                     | 12     | 55  | 102 | 2   | ○               | -  |
| 1181043Z9        | 1182044Z9   | HBDPCE/W 2 03D 1180-102055            | 11,80                                     | 12     | 55  | 102 | 2   | ⊗               | ○  |
| 1181044Z9        | -           | HBDPCE/W 2 03D 1190-102055            | 11,90                                     | 12     | 55  | 102 | 2   | ○               | -  |
| 1181045Z9        | 1182045Z9   | HBDPCE/W 2 03D 1200-102055            | 12,00                                     | 12     | 55  | 102 | 2   | ⊗               | ○  |
| 1181046Z9        | 1182046Z9   | HBDPCE/W 2 03D 1250-107060            | 12,50                                     | 14     | 60  | 107 | 2   | ⊗               | ○  |
| 1181770Z9        | 1182047Z9   | HBDPCE/W 2 03D 1280-107060            | 12,80                                     | 14     | 60  | 107 | 2   | ⊗               | ○  |
| 1181047Z9        | 1182048Z9   | HBDPCE/W 2 03D 1300-107060            | 13,00                                     | 14     | 60  | 107 | 2   | ⊗               | ⊗  |
| 1182399Z9        | 1182402Z9   | HBDPCE/W 2 03D 1320-107060            | 13,20                                     | 14     | 60  | 107 | 2   | ⊗               | ○  |
| 1181048Z9        | 1182049Z9   | HBDPCE/W 2 03D 1350-107060            | 13,50                                     | 14     | 60  | 107 | 2   | ⊗               | ○  |
| 1181772Z9        | 1182050Z9   | HBDPCE/W 2 03D 1380-107060            | 13,80                                     | 14     | 60  | 107 | 2   | ⊗               | ⊗  |
| 1181049Z9        | 1182051Z9   | HBDPCE/W 2 03D 1400-107060            | 14,00                                     | 14     | 60  | 107 | 2   | ⊗               | ⊗  |
| 1181774Z9        | 1182052Z9   | HBDPCE/W 2 03D 1420-115065            | 14,20                                     | 16     | 65  | 115 | 2   | ⊗               | ○  |
| 1181050Z9        | 1182053Z9   | HBDPCE/W 2 03D 1450-115065            | 14,50                                     | 16     | 65  | 115 | 2   | ⊗               | ○  |
| 1181776Z9        | 1182054Z9   | HBDPCE/W 2 03D 1480-115065            | 14,80                                     | 16     | 65  | 115 | 2   | ⊗               | ⊗  |
| 1181051Z9        | 1182055Z9   | HBDPCE/W 2 03D 1500-115065            | 15,00                                     | 16     | 65  | 115 | 2   | ⊗               | ⊗  |
| 1181052Z9        | 1182056Z9   | HBDPCE/W 2 03D 1550-115065            | 15,50                                     | 16     | 65  | 115 | 2   | ⊗               | ⊗  |
| 1181778Z9        | 1182057Z9   | HBDPCE/W 2 03D 1580-115065            | 15,80                                     | 16     | 65  | 115 | 2   | ⊗               | ⊗  |
| 1181053Z9        | 1182058Z9   | HBDPCE/W 2 03D 1600-115065            | 16,00                                     | 16     | 65  | 115 | 2   | ⊗               | ○  |
| 1181054Z9        | 1182059Z9   | HBDPCE/W 2 03D 1650-123073            | 16,50                                     | 18     | 73  | 123 | 2   | ⊗               | ⊗  |
| 1181055Z9        | 1182060Z9   | HBDPCE/W 2 03D 1700-123073            | 17,00                                     | 18     | 73  | 123 | 2   | ⊗               | ○  |
| 1181056Z9        | 1182061Z9   | HBDPCE/W 2 03D 1750-123073            | 17,50                                     | 18     | 73  | 123 | 2   | ⊗               | ○  |
| 1181057Z9        | 1182062Z9   | HBDPCE/W 2 03D 1800-123073            | 18,00                                     | 18     | 73  | 123 | 2   | ⊗               | ○  |
| 1181058Z9        | 1182063Z9   | HBDPCE/W 2 03D 1850-131079            | 18,50                                     | 20     | 79  | 131 | 2   | ⊗               | ⊗  |
| 1181059Z9        | 1182064Z9   | HBDPCE/W 2 03D 1900-131079            | 19,00                                     | 20     | 79  | 131 | 2   | ⊗               | ⊗  |
| 1181060Z9        | 1182065Z9   | HBDPCE/W 2 03D 1950-131079            | 19,50                                     | 20     | 79  | 131 | 2   | ⊗               | ⊗  |
| 1181061Z9        | 1182066Z9   | HBDPCE/W 2 03D 2000-131079            | 20,00                                     | 20     | 79  | 131 | 2   | ⊗               | ○  |

⊗ Stock item | Produto de stock | Itens de stock

○ Available under request | Disponível sobre consulta | Disponible bajo consulta

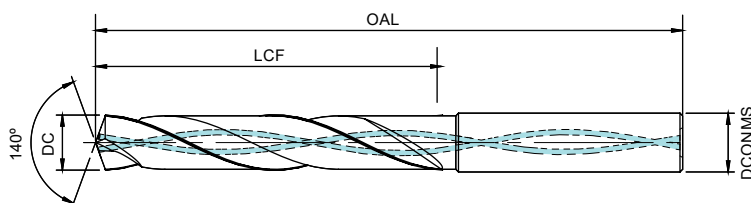

|                |                   |
|----------------|-------------------|
| P              | K                 |
| HRC<br>≤<br>60 | IT8-9<br>IT class |

| Drill Dia. DC   | DC3,0  | 3,0<DC≤6,0 | 6,0<DC≤10,0 | 10,0<DC≤18,0 | 18,0<DC≤20,0 |
|-----------------|--------|------------|-------------|--------------|--------------|
| Hole Tolerances | +0,002 | +0,004     | +0,006      | +0,007       | +0,008       |
|                 | +0,012 | +0,016     | +0,021      | +0,025       | +0,028       |

| Order code       |             | Reference<br>Referência<br>Referencia | Dimensions   Dimensões   Dimensiones (mm) |        |     |     | NOF | Stock<br>PHU920 |    |
|------------------|-------------|---------------------------------------|---|--------|-----|-----|-----|-----------------|----|
| HA (Cylindrical) | HB (Weldon) |                                       | DC  | DCONMS | LCF | OAL |     | HA              | HB |
| 1180788Z9        | 1182067Z9   | HBDPCE/W 2 05D 0300-066028            | 3,00                                      | 6      | 28  | 66  | 2   | ☉               | ☉  |
| 1181160Z9        | 1182068Z9   | HBDPCE/W 2 05D 0310-066028            | 3,10                                      | 6      | 28  | 66  | 2   | ☉               | ○  |
| 1181161Z9        | 1182069Z9   | HBDPCE/W 2 05D 0320-066028            | 3,20                                      | 6      | 28  | 66  | 2   | ☉               | ○  |
| 1181825Z9        | 1182070Z9   | HBDPCE/W 2 05D 0325-066028            | 3,25                                      | 6      | 28  | 66  | 2   | ☉               | ☉  |
| 1181162Z9        | 1182071Z9   | HBDPCE/W 2 05D 0330-066028            | 3,30                                      | 6      | 28  | 66  | 2   | ☉               | ☉  |
| 1180797Z9        | 1182072Z9   | HBDPCE/W 2 05D 0340-066028            | 3,40                                      | 6      | 28  | 66  | 2   | ☉               | ○  |
| 1181163Z9        | 1182073Z9   | HBDPCE/W 2 05D 0350-066028            | 3,50                                      | 6      | 28  | 66  | 2   | ☉               | ☉  |
| 1181164Z9        | 1182074Z9   | HBDPCE/W 2 05D 0360-066028            | 3,60                                      | 6      | 28  | 66  | 2   | ☉               | ○  |
| 1180798Z9        | 1182075Z9   | HBDPCE/W 2 05D 0370-066028            | 3,70                                      | 6      | 28  | 66  | 2   | ☉               | ☉  |
| 1181165Z9        | 1182076Z9   | HBDPCE/W 2 05D 0380-074036            | 3,80                                      | 6      | 36  | 74  | 2   | ☉               | ○  |
| 1181166Z9        | 1182077Z9   | HBDPCE/W 2 05D 0390-074036            | 3,90                                      | 6      | 36  | 74  | 2   | ☉               | ○  |
| 1181167Z9        | 1182078Z9   | HBDPCE/W 2 05D 0400-074036            | 4,00                                      | 6      | 36  | 74  | 2   | ☉               | ☉  |
| 1181168Z9        | 1182079Z9   | HBDPCE/W 2 05D 0410-074036            | 4,10                                      | 6      | 36  | 74  | 2   | ☉               | ☉  |
| 1180799Z9        | 1182080Z9   | HBDPCE/W 2 05D 0420-074036            | 4,20                                      | 6      | 36  | 74  | 2   | ☉               | ☉  |
| 1180800Z9        | 1182081Z9   | HBDPCE/W 2 05D 0430-074036            | 4,30                                      | 6      | 36  | 74  | 2   | ☉               | ☉  |
| 1181169Z9        | 1182082Z9   | HBDPCE/W 2 05D 0440-074036            | 4,40                                      | 6      | 36  | 74  | 2   | ☉               | ☉  |
| 1181170Z9        | 1182083Z9   | HBDPCE/W 2 05D 0450-074036            | 4,50                                      | 6      | 36  | 74  | 2   | ☉               | ☉  |
| 1181171Z9        | 1182084Z9   | HBDPCE/W 2 05D 0460-074036            | 4,60                                      | 6      | 36  | 74  | 2   | ☉               | ☉  |
| 1181535Z9        | 1182085Z9   | HBDPCE/W 2 05D 0465-074036            | 4,65                                      | 6      | 36  | 74  | 2   | ☉               | ☉  |
| 1181172Z9        | 1182086Z9   | HBDPCE/W 2 05D 0470-074036            | 4,70                                      | 6      | 36  | 74  | 2   | ☉               | ☉  |
| 1181173Z9        | 1182087Z9   | HBDPCE/W 2 05D 0480-082044            | 4,80                                      | 6      | 44  | 82  | 2   | ☉               | ○  |
| 1181174Z9        | 1182088Z9   | HBDPCE/W 2 05D 0490-082044            | 4,90                                      | 6      | 44  | 82  | 2   | ☉               | ☉  |
| 1180801Z9        | 1182089Z9   | HBDPCE/W 2 05D 0500-082044            | 5,00                                      | 6      | 44  | 82  | 2   | ☉               | ☉  |
| 1181175Z9        | 1182090Z9   | HBDPCE/W 2 05D 0510-082044            | 5,10                                      | 6      | 44  | 82  | 2   | ☉               | ☉  |
| 1181176Z9        | 1182091Z9   | HBDPCE/W 2 05D 0520-082044            | 5,20                                      | 6      | 44  | 82  | 2   | ☉               | ☉  |
| 1181177Z9        | 1182092Z9   | HBDPCE/W 2 05D 0530-082044            | 5,30                                      | 6      | 44  | 82  | 2   | ☉               | ☉  |

☉ Stock item | Produto de stock | Itens de stock

○ Available under request | Disponível sobre consulta | Disponible bajo consulta

Continue next page

## HBDPCE/W 2 05D

Solid carbide drills | Brocas de metal duro | Brocas en metal duro

| Order code       |             | Reference<br>Referência<br>Referencia | Dimensions   Dimensões   Dimensiones (mm) |        |     |     | NOF | Stock<br>PHU920 |    |
|------------------|-------------|---------------------------------------|---|--------|-----|-----|-----|-----------------|----|
| HA (Cylindrical) | HB (Weldon) |                                       | DC  | DCONMS | LCF | OAL |     | HA              | HB |
| 1181178Z9        | 1182093Z9   | HBDPCE/W 2 05D 0540-082044            | 5,40                                      | 6      | 44  | 82  | 2   | ⊗               | ⊗  |
| 1181179Z9        | 1182094Z9   | HBDPCE/W 2 05D 0550-082044            | 5,50                                      | 6      | 44  | 82  | 2   | ⊗               | ⊗  |
| 1181536Z9        | 1182095Z9   | HBDPCE/W 2 05D 0555-082044            | 5,55                                      | 6      | 44  | 82  | 2   | ⊗               | ⊗  |
| 1181180Z9        | 1182096Z9   | HBDPCE/W 2 05D 0560-082044            | 5,60                                      | 6      | 44  | 82  | 2   | ⊗               | ⊗  |
| 1181181Z9        | 1182097Z9   | HBDPCE/W 2 05D 0570-082044            | 5,70                                      | 6      | 44  | 82  | 2   | ⊗               | ○  |
| 1180802Z9        | 1182098Z9   | HBDPCE/W 2 05D 0580-082044            | 5,80                                      | 6      | 44  | 82  | 2   | ⊗               | ⊗  |
| 1181182Z9        | 1182099Z9   | HBDPCE/W 2 05D 0590-082044            | 5,90                                      | 6      | 44  | 82  | 2   | ⊗               | ○  |
| 1181183Z9        | 1182100Z9   | HBDPCE/W 2 05D 0600-082044            | 6,00                                      | 6      | 44  | 82  | 2   | ⊗               | ⊗  |
| 1181184Z9        | 1182101Z9   | HBDPCE/W 2 05D 0610-091053            | 6,10                                      | 8      | 53  | 91  | 2   | ⊗               | ⊗  |
| 1181185Z9        | 1182102Z9   | HBDPCE/W 2 05D 0620-091053            | 6,20                                      | 8      | 53  | 91  | 2   | ⊗               | ⊗  |
| 1181186Z9        | 1182103Z9   | HBDPCE/W 2 05D 0630-091053            | 6,30                                      | 8      | 53  | 91  | 2   | ⊗               | ○  |
| 1181187Z9        | 1182104Z9   | HBDPCE/W 2 05D 0640-091053            | 6,40                                      | 8      | 53  | 91  | 2   | ⊗               | ○  |
| 1180787Z9        | 1182105Z9   | HBDPCE/W 2 05D 0650-091053            | 6,50                                      | 8      | 53  | 91  | 2   | ⊗               | ⊗  |
| 1181188Z9        | 1182106Z9   | HBDPCE/W 2 05D 0660-091053            | 6,60                                      | 8      | 53  | 91  | 2   | ⊗               | ⊗  |
| 1181189Z9        | 1182107Z9   | HBDPCE/W 2 05D 0670-091053            | 6,70                                      | 8      | 53  | 91  | 2   | ⊗               | ⊗  |
| 1180803Z9        | 1182108Z9   | HBDPCE/W 2 05D 0680-091053            | 6,80                                      | 8      | 53  | 91  | 2   | ⊗               | ⊗  |
| 1181190Z9        | 1182109Z9   | HBDPCE/W 2 05D 0690-091053            | 6,90                                      | 8      | 53  | 91  | 2   | ⊗               | ⊗  |
| 1180804Z9        | 1182110Z9   | HBDPCE/W 2 05D 0700-091053            | 7,00                                      | 8      | 53  | 91  | 2   | ⊗               | ⊗  |
| 1181191Z9        | 1182111Z9   | HBDPCE/W 2 05D 0710-091053            | 7,10                                      | 8      | 53  | 91  | 2   | ⊗               | ⊗  |
| 1181192Z9        | 1182112Z9   | HBDPCE/W 2 05D 0720-091053            | 7,20                                      | 8      | 53  | 91  | 2   | ⊗               | ⊗  |
| 1181193Z9        | 1182113Z9   | HBDPCE/W 2 05D 0730-091053            | 7,30                                      | 8      | 53  | 91  | 2   | ⊗               | ⊗  |
| 1180805Z9        | 1182114Z9   | HBDPCE/W 2 05D 0740-091053            | 7,40                                      | 8      | 53  | 91  | 2   | ⊗               | ⊗  |
| 1181194Z9        | 1182115Z9   | HBDPCE/W 2 05D 0750-091053            | 7,50                                      | 8      | 53  | 91  | 2   | ⊗               | ⊗  |
| 1181195Z9        | 1182116Z9   | HBDPCE/W 2 05D 0760-091053            | 7,60                                      | 8      | 53  | 91  | 2   | ⊗               | ⊗  |
| 1181196Z9        | 1182117Z9   | HBDPCE/W 2 05D 0770-091053            | 7,70                                      | 8      | 53  | 91  | 2   | ⊗               | ⊗  |
| 1181197Z9        | 1182118Z9   | HBDPCE/W 2 05D 0780-091053            | 7,80                                      | 8      | 53  | 91  | 2   | ⊗               | ⊗  |
| 1181198Z9        | 1182119Z9   | HBDPCE/W 2 05D 0790-091053            | 7,90                                      | 8      | 53  | 91  | 2   | ⊗               | ⊗  |
| 1181199Z9        | 1182120Z9   | HBDPCE/W 2 05D 0800-091053            | 8,00                                      | 8      | 53  | 91  | 2   | ⊗               | ⊗  |
| 1181200Z9        | 1182121Z9   | HBDPCE/W 2 05D 0810-103061            | 8,10                                      | 10     | 61  | 103 | 2   | ⊗               | ○  |
| 1181201Z9        | 1182122Z9   | HBDPCE/W 2 05D 0820-103061            | 8,20                                      | 10     | 61  | 103 | 2   | ⊗               | ⊗  |
| 1181202Z9        | 1182123Z9   | HBDPCE/W 2 05D 0830-103061            | 8,30                                      | 10     | 61  | 103 | 2   | ⊗               | ○  |
| 1181203Z9        | 1182124Z9   | HBDPCE/W 2 05D 0840-103061            | 8,40                                      | 10     | 61  | 103 | 2   | ⊗               | ⊗  |
| 1180806Z9        | 1182125Z9   | HBDPCE/W 2 05D 0850-103061            | 8,50                                      | 10     | 61  | 103 | 2   | ⊗               | ⊗  |
| 1181204Z9        | 1182126Z9   | HBDPCE/W 2 05D 0860-103061            | 8,60                                      | 10     | 61  | 103 | 2   | ⊗               | ⊗  |
| 1181205Z9        | 1182127Z9   | HBDPCE/W 2 05D 0870-103061            | 8,70                                      | 10     | 61  | 103 | 2   | ⊗               | ⊗  |
| 1181206Z9        | 1182128Z9   | HBDPCE/W 2 05D 0880-103061            | 8,80                                      | 10     | 61  | 103 | 2   | ⊗               | ⊗  |
| 1181207Z9        | 1182129Z9   | HBDPCE/W 2 05D 0890-103061            | 8,90                                      | 10     | 61  | 103 | 2   | ⊗               | ○  |
| 1180807Z9        | 1182130Z9   | HBDPCE/W 2 05D 0900-103061            | 9,00                                      | 10     | 61  | 103 | 2   | ⊗               | ⊗  |
| 1181208Z9        | 1182131Z9   | HBDPCE/W 2 05D 0910-103061            | 9,10                                      | 10     | 61  | 103 | 2   | ⊗               | ⊗  |
| 1181209Z9        | 1182132Z9   | HBDPCE/W 2 05D 0920-103061            | 9,20                                      | 10     | 61  | 103 | 2   | ⊗               | ○  |
| 1181210Z9        | 1182133Z9   | HBDPCE/W 2 05D 0930-103061            | 9,30                                      | 10     | 61  | 103 | 2   | ⊗               | ⊗  |
| 1181211Z9        | 1182134Z9   | HBDPCE/W 2 05D 0940-103061            | 9,40                                      | 10     | 61  | 103 | 2   | ⊗               | ⊗  |
| 1181212Z9        | 1182135Z9   | HBDPCE/W 2 05D 0950-103061            | 9,50                                      | 10     | 61  | 103 | 2   | ⊗               | ⊗  |
| 1181213Z9        | 1182136Z9   | HBDPCE/W 2 05D 0960-103061            | 9,60                                      | 10     | 61  | 103 | 2   | ⊗               | ⊗  |
| 1181214Z9        | 1182137Z9   | HBDPCE/W 2 05D 0970-103061            | 9,70                                      | 10     | 61  | 103 | 2   | ⊗               | ⊗  |
| 1181215Z9        | 1182138Z9   | HBDPCE/W 2 05D 0980-103061            | 9,80                                      | 10     | 61  | 103 | 2   | ⊗               | ⊗  |

⊗ Stock item | Produto de stock | Itens de stock

○ Available under request | Disponível sobre consulta | Disponible bajo consulta

Continue next page

# HBDPCE/W 2 05D

Solid carbide drills | Brocas de metal duro | Brocas en metal duro

| Order code       |             | Reference<br>Referência<br>Referencia | Dimensions   Dimensões   Dimensiones (mm) |        |     |     | NOF | Stock<br>PHU920 |    |
|------------------|-------------|---------------------------------------|---|--------|-----|-----|-----|-----------------|----|
| HA (Cylindrical) | HB (Weldon) |                                       | DC  | DCONMS | LCF | OAL |     | HA              | HB |
| 1181216Z9        | 1182139Z9   | HBDPCE/W 2 05D 0990-103061            | 9,90                                      | 10     | 61  | 103 | 2   | ⊗               | ○  |
| 1181217Z9        | 1182140Z9   | HBDPCE/W 2 05D 1000-103061            | 10,00                                     | 10     | 61  | 103 | 2   | ⊗               | ⊗  |
| 1181218Z9        | 1182141Z9   | HBDPCE/W 2 05D 1010-118071            | 10,10                                     | 12     | 71  | 118 | 2   | ⊗               | ⊗  |
| 1180808Z9        | 1182142Z9   | HBDPCE/W 2 05D 1020-118071            | 10,20                                     | 12     | 71  | 118 | 2   | ⊗               | ○  |
| 1181219Z9        | 1182143Z9   | HBDPCE/W 2 05D 1030-118071            | 10,30                                     | 12     | 71  | 118 | 2   | ⊗               | ⊗  |
| 1181220Z9        | 1182144Z9   | HBDPCE/W 2 05D 1040-118071            | 10,40                                     | 12     | 71  | 118 | 2   | ⊗               | ○  |
| 1180809Z9        | 1182145Z9   | HBDPCE/W 2 05D 1050-118071            | 10,50                                     | 12     | 71  | 118 | 2   | ⊗               | ⊗  |
| 1180810Z9        | -           | HBDPCE/W 2 05D 1060-118071            | 10,60                                     | 12     | 71  | 118 | 2   | ⊗               | -  |
| 1181221Z9        | -           | HBDPCE/W 2 05D 1070-118071            | 10,70                                     | 12     | 71  | 118 | 2   | ⊗               | -  |
| 1181222Z9        | 1182146Z9   | HBDPCE/W 2 05D 1080-118071            | 10,80                                     | 12     | 71  | 118 | 2   | ⊗               | ⊗  |
| 1181223Z9        | -           | HBDPCE/W 2 05D 1090-118071            | 10,90                                     | 12     | 71  | 118 | 2   | ⊗               | -  |
| 1180811Z9        | 1182147Z9   | HBDPCE/W 2 05D 1100-118071            | 11,00                                     | 12     | 71  | 118 | 2   | ⊗               | ⊗  |
| 1181224Z9        | 1182148Z9   | HBDPCE/W 2 05D 1110-118071            | 11,10                                     | 12     | 71  | 118 | 2   | ⊗               | ⊗  |
| 1181225Z9        | 1182149Z9   | HBDPCE/W 2 05D 1120-118071            | 11,20                                     | 12     | 71  | 118 | 2   | ⊗               | ⊗  |
| 1181226Z9        | 1182150Z9   | HBDPCE/W 2 05D 1130-118071            | 11,30                                     | 12     | 71  | 118 | 2   | ⊗               | ⊗  |
| 1181227Z9        | -           | HBDPCE/W 2 05D 1140-118071            | 11,40                                     | 12     | 71  | 118 | 2   | ⊗               | -  |
| 1180812Z9        | 1182151Z9   | HBDPCE/W 2 05D 1150-118071            | 11,50                                     | 12     | 71  | 118 | 2   | ⊗               | ○  |
| 1181228Z9        | -           | HBDPCE/W 2 05D 1160-118071            | 11,60                                     | 12     | 71  | 118 | 2   | ⊗               | -  |
| 1181229Z9        | -           | HBDPCE/W 2 05D 1170-118071            | 11,70                                     | 12     | 71  | 118 | 2   | ⊗               | -  |
| 1181230Z9        | 1182152Z9   | HBDPCE/W 2 05D 1180-118071            | 11,80                                     | 12     | 71  | 118 | 2   | ⊗               | ⊗  |
| 1181231Z9        | -           | HBDPCE/W 2 05D 1190-118071            | 11,90                                     | 12     | 71  | 118 | 2   | ⊗               | -  |
| 1180813Z9        | 1182153Z9   | HBDPCE/W 2 05D 1200-118071            | 12,00                                     | 12     | 71  | 118 | 2   | ⊗               | ○  |
| 1181805Z9        | 1182154Z9   | HBDPCE/W 2 05D 1220-124077            | 12,20                                     | 14     | 77  | 124 | 2   | ⊗               | ○  |
| 1181232Z9        | 1182155Z9   | HBDPCE/W 2 05D 1250-124077            | 12,50                                     | 14     | 77  | 124 | 2   | ⊗               | ○  |
| 1181806Z9        | 1182156Z9   | HBDPCE/W 2 05D 1280-124077            | 12,80                                     | 14     | 77  | 124 | 2   | ⊗               | ○  |
| 1180814Z9        | 1182157Z9   | HBDPCE/W 2 05D 1300-124077            | 13,00                                     | 14     | 77  | 124 | 2   | ⊗               | ⊗  |
| 1182267Z9        | -           | HBDPCE/W 2 05D 1320-124077            | 13,20                                     | 14     | 77  | 124 | 2   | ⊗               | -  |
| 1181233Z9        | 1182158Z9   | HBDPCE/W 2 05D 1350-124077            | 13,50                                     | 14     | 77  | 124 | 2   | ⊗               | ⊗  |
| 1181807Z9        | 1182159Z9   | HBDPCE/W 2 05D 1380-124077            | 13,80                                     | 14     | 77  | 124 | 2   | ⊗               | ⊗  |
| 1181808Z9        | 1182160Z9   | HBDPCE/W 2 05D 1390-124077            | 13,90                                     | 14     | 77  | 124 | 2   | ⊗               | ⊗  |
| 1181234Z9        | 1182161Z9   | HBDPCE/W 2 05D 1400-124077            | 14,00                                     | 14     | 77  | 124 | 2   | ⊗               | ⊗  |
| 1181809Z9        | 1182162Z9   | HBDPCE/W 2 05D 1420-133083            | 14,20                                     | 16     | 83  | 133 | 2   | ⊗               | ○  |
| 1181235Z9        | 1182163Z9   | HBDPCE/W 2 05D 1450-133083            | 14,50                                     | 16     | 83  | 133 | 2   | ⊗               | ⊗  |
| 1181810Z9        | 1182164Z9   | HBDPCE/W 2 05D 1480-133083            | 14,80                                     | 16     | 83  | 133 | 2   | ⊗               | ⊗  |
| 1181236Z9        | 1182165Z9   | HBDPCE/W 2 05D 1500-133083            | 15,00                                     | 16     | 83  | 133 | 2   | ⊗               | ⊗  |
| 1181811Z9        | 1182166Z9   | HBDPCE/W 2 05D 1520-133083            | 15,20                                     | 16     | 83  | 133 | 2   | ⊗               | ○  |
| 1181237Z9        | 1182167Z9   | HBDPCE/W 2 05D 1550-133083            | 15,50                                     | 16     | 83  | 133 | 2   | ⊗               | ⊗  |
| 1181812Z9        | 1182168Z9   | HBDPCE/W 2 05D 1570-133083            | 15,70                                     | 16     | 83  | 133 | 2   | ⊗               | ⊗  |
| 1180815Z9        | 1182169Z9   | HBDPCE/W 2 05D 1580-133083            | 15,80                                     | 16     | 83  | 133 | 2   | ⊗               | ⊗  |
| 1181238Z9        | 1182170Z9   | HBDPCE/W 2 05D 1600-133083            | 16,00                                     | 16     | 83  | 133 | 2   | ⊗               | ⊗  |
| 1181239Z9        | 1182171Z9   | HBDPCE/W 2 05D 1650-143093            | 16,50                                     | 18     | 93  | 143 | 2   | ⊗               | ⊗  |
| 1181240Z9        | 1182172Z9   | HBDPCE/W 2 05D 1700-143093            | 17,00                                     | 18     | 93  | 143 | 2   | ⊗               | ⊗  |
| 1180816Z9        | 1182173Z9   | HBDPCE/W 2 05D 1750-143093            | 17,50                                     | 18     | 93  | 143 | 2   | ⊗               | ○  |
| 1181241Z9        | 1182174Z9   | HBDPCE/W 2 05D 1800-143093            | 18,00                                     | 18     | 93  | 143 | 2   | ⊗               | ○  |
| 1181242Z9        | 1182175Z9   | HBDPCE/W 2 05D 1850-153101            | 18,50                                     | 20     | 101 | 153 | 2   | ⊗               | ○  |
| 1181243Z9        | 1182176Z9   | HBDPCE/W 2 05D 1900-153101            | 19,00                                     | 20     | 101 | 153 | 2   | ⊗               | ⊗  |
| 1181244Z9        | 1182177Z9   | HBDPCE/W 2 05D 1950-153101            | 19,50                                     | 20     | 101 | 153 | 2   | ⊗               | ⊗  |
| 1181245Z9        | 1182178Z9   | HBDPCE/W 2 05D 2000-153101            | 20,00                                     | 20     | 101 | 153 | 2   | ⊗               | ⊗  |

⊗ Stock item | Produto de stock | Itens de stock

○ Available under request | Disponível sobre consulta | Disponible bajo consulta

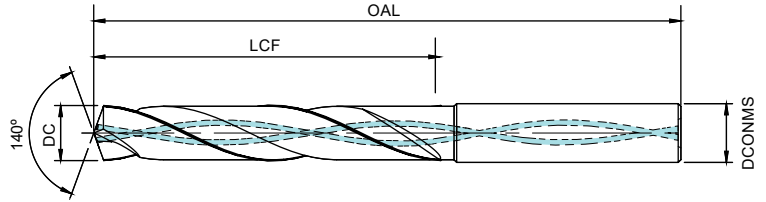

|          |                   |
|----------|-------------------|
| P        | K                 |
| HRC ≤ 48 | IT8-9<br>IT class |

| Drill Dia. DC   | 3,0<DC≤5,0 | 5,0<DC≤6,0 | 6,0<DC≤10,0 | 10,0<DC≤12,0 |
|-----------------|------------|------------|-------------|--------------|
| Hole Tolerances | +0,002     | +0,004     | +0,006      | +0,007       |
|                 | +0,012     | +0,016     | +0,021      | +0,025       |

| Order code       |             | Reference<br>Referência<br>Referencia | Dimensions   Dimensões   Dimensiones (mm) |        |     |     | NOF | Stock<br>PHU920 |    |
|------------------|-------------|---------------------------------------|---|--------|-----|-----|-----|-----------------|----|
| HA (Cylindrical) | HB (Weldon) |                                       | DC  | DCONMS | LCF | OAL |     | HA              | HB |
| 1181246Z9        | -           | HBDPCE/W 2 08D 0300-072034            | 3,00                                      | 6      | 34  | 72  | 2   | ⊗               | -  |
| 1181247Z9        | -           | HBDPCE/W 2 08D 0310-072034            | 3,10                                      | 6      | 34  | 72  | 2   | ○               | -  |
| 1181248Z9        | -           | HBDPCE/W 2 08D 0320-072034            | 3,20                                      | 6      | 34  | 72  | 2   | ○               | -  |
| 1181249Z9        | -           | HBDPCE/W 2 08D 0330-072034            | 3,30                                      | 6      | 34  | 72  | 2   | ⊗               | -  |
| 1181250Z9        | -           | HBDPCE/W 2 08D 0340-072034            | 3,40                                      | 6      | 34  | 72  | 2   | ⊗               | -  |
| 1181251Z9        | -           | HBDPCE/W 2 08D 0350-072034            | 3,50                                      | 6      | 34  | 72  | 2   | ○               | -  |
| 1181252Z9        | -           | HBDPCE/W 2 08D 0360-072034            | 3,60                                      | 6      | 34  | 72  | 2   | ○               | -  |
| 1181253Z9        | -           | HBDPCE/W 2 08D 0370-072034            | 3,70                                      | 6      | 34  | 72  | 2   | ⊗               | -  |
| 1181254Z9        | -           | HBDPCE/W 2 08D 0380-081043            | 3,80                                      | 6      | 43  | 81  | 2   | ○               | -  |
| 1181255Z9        | -           | HBDPCE/W 2 08D 0390-081043            | 3,90                                      | 6      | 43  | 81  | 2   | ○               | -  |
| 1181256Z9        | -           | HBDPCE/W 2 08D 0400-081043            | 4,00                                      | 6      | 43  | 81  | 2   | ⊗               | -  |
| 1181257Z9        | -           | HBDPCE/W 2 08D 0410-081043            | 4,10                                      | 6      | 43  | 81  | 2   | ○               | -  |
| 1181258Z9        | -           | HBDPCE/W 2 08D 0420-081043            | 4,20                                      | 6      | 43  | 81  | 2   | ⊗               | -  |
| 1181259Z9        | -           | HBDPCE/W 2 08D 0430-081043            | 4,30                                      | 6      | 43  | 81  | 2   | ⊗               | -  |
| 1181260Z9        | -           | HBDPCE/W 2 08D 0440-081043            | 4,40                                      | 6      | 43  | 81  | 2   | ○               | -  |
| 1181261Z9        | -           | HBDPCE/W 2 08D 0450-081043            | 4,50                                      | 6      | 43  | 81  | 2   | ○               | -  |
| 1181262Z9        | -           | HBDPCE/W 2 08D 0460-081043            | 4,60                                      | 6      | 43  | 81  | 2   | ○               | -  |
| 1181263Z9        | -           | HBDPCE/W 2 08D 0470-081043            | 4,70                                      | 6      | 43  | 81  | 2   | ○               | -  |
| 1181264Z9        | -           | HBDPCE/W 2 08D 0480-095057            | 4,80                                      | 6      | 57  | 95  | 2   | ⊗               | -  |
| 1181265Z9        | -           | HBDPCE/W 2 08D 0490-095057            | 4,90                                      | 6      | 57  | 95  | 2   | ○               | -  |
| 1181266Z9        | -           | HBDPCE/W 2 08D 0500-095057            | 5,00                                      | 6      | 57  | 95  | 2   | ⊗               | -  |
| 1181267Z9        | -           | HBDPCE/W 2 08D 0510-095057            | 5,10                                      | 6      | 57  | 95  | 2   | ⊗               | -  |
| 1181268Z9        | -           | HBDPCE/W 2 08D 0520-095057            | 5,20                                      | 6      | 57  | 95  | 2   | ○               | -  |
| 1181269Z9        | -           | HBDPCE/W 2 08D 0530-095057            | 5,30                                      | 6      | 57  | 95  | 2   | ○               | -  |
| 1181270Z9        | -           | HBDPCE/W 2 08D 0540-095057            | 5,40                                      | 6      | 57  | 95  | 2   | ○               | -  |
| 1181271Z9        | -           | HBDPCE/W 2 08D 0550-095057            | 5,50                                      | 6      | 57  | 95  | 2   | ⊗               | -  |

⊗ Stock item | Produto de stock | Itens de stock

○ Available under request | Disponível sobre consulta | Disponible bajo consulta

Continue next page

# HBDPCE/W 2 08D

Solid carbide drills | Brocas de metal duro | Brocas en metal duro

| Order code       |             | Reference<br>Referência<br>Referencia | Dimensions   Dimensões   Dimensiones (mm) |        |     |     | NOF | Stock<br>PHU920 |    |
|------------------|-------------|---------------------------------------|---|--------|-----|-----|-----|-----------------|----|
| HA (Cylindrical) | HB (Weldon) |                                       | DC  | DCONMS | LCF | OAL |     | HA              | HB |
| 1181272Z9        | -           | HBDPCE/W 2 08D 0560-095057            | 5,60                                      | 6      | 57  | 95  | 2   | ○               | -  |
| 1181273Z9        | -           | HBDPCE/W 2 08D 0570-095057            | 5,70                                      | 6      | 57  | 95  | 2   | ○               | -  |
| 1181274Z9        | -           | HBDPCE/W 2 08D 0580-095057            | 5,80                                      | 6      | 57  | 95  | 2   | ○               | -  |
| 1181275Z9        | -           | HBDPCE/W 2 08D 0590-095057            | 5,90                                      | 6      | 57  | 95  | 2   | ○               | -  |
| 1181276Z9        | -           | HBDPCE/W 2 08D 0600-095057            | 6,00                                      | 6      | 57  | 95  | 2   | ⊗               | -  |
| 1181277Z9        | -           | HBDPCE/W 2 08D 0610-114076            | 6,10                                      | 8      | 76  | 114 | 2   | ○               | -  |
| 1181278Z9        | -           | HBDPCE/W 2 08D 0620-114076            | 6,20                                      | 8      | 76  | 114 | 2   | ○               | -  |
| 1181279Z9        | -           | HBDPCE/W 2 08D 0630-114076            | 6,30                                      | 8      | 76  | 114 | 2   | ○               | -  |
| 1181280Z9        | -           | HBDPCE/W 2 08D 0640-114076            | 6,40                                      | 8      | 76  | 114 | 2   | ○               | -  |
| 1181281Z9        | -           | HBDPCE/W 2 08D 0650-114076            | 6,50                                      | 8      | 76  | 114 | 2   | ⊗               | -  |
| 1181282Z9        | -           | HBDPCE/W 2 08D 0660-114076            | 6,60                                      | 8      | 76  | 114 | 2   | ○               | -  |
| 1181283Z9        | -           | HBDPCE/W 2 08D 0670-114076            | 6,70                                      | 8      | 76  | 114 | 2   | ○               | -  |
| 1181284Z9        | -           | HBDPCE/W 2 08D 0680-114076            | 6,80                                      | 8      | 76  | 114 | 2   | ⊗               | -  |
| 1181285Z9        | -           | HBDPCE/W 2 08D 0690-114076            | 6,90                                      | 8      | 76  | 114 | 2   | ○               | -  |
| 1181286Z9        | -           | HBDPCE/W 2 08D 0700-114076            | 7,00                                      | 8      | 76  | 114 | 2   | ⊗               | -  |
| 1181287Z9        | -           | HBDPCE/W 2 08D 0710-114076            | 7,10                                      | 8      | 76  | 114 | 2   | ○               | -  |
| 1181288Z9        | -           | HBDPCE/W 2 08D 0720-114076            | 7,20                                      | 8      | 76  | 114 | 2   | ○               | -  |
| 1181289Z9        | -           | HBDPCE/W 2 08D 0730-114076            | 7,30                                      | 8      | 76  | 114 | 2   | ○               | -  |
| 1181290Z9        | -           | HBDPCE/W 2 08D 0740-114076            | 7,40                                      | 8      | 76  | 114 | 2   | ○               | -  |
| 1181291Z9        | -           | HBDPCE/W 2 08D 0750-114076            | 7,50                                      | 8      | 76  | 114 | 2   | ○               | -  |
| 1181292Z9        | -           | HBDPCE/W 2 08D 0760-114076            | 7,60                                      | 8      | 76  | 114 | 2   | ○               | -  |
| 1181293Z9        | -           | HBDPCE/W 2 08D 0770-114076            | 7,70                                      | 8      | 76  | 114 | 2   | ○               | -  |
| 1181294Z9        | -           | HBDPCE/W 2 08D 0780-114076            | 7,80                                      | 8      | 76  | 114 | 2   | ⊗               | -  |
| 1181295Z9        | -           | HBDPCE/W 2 08D 0790-114076            | 7,90                                      | 8      | 76  | 114 | 2   | ○               | -  |
| 1181296Z9        | -           | HBDPCE/W 2 08D 0800-114076            | 8,00                                      | 8      | 76  | 114 | 2   | ⊗               | -  |
| 1181297Z9        | -           | HBDPCE/W 2 08D 0810-142095            | 8,10                                      | 10     | 95  | 142 | 2   | ○               | -  |
| 1181298Z9        | -           | HBDPCE/W 2 08D 0820-142095            | 8,20                                      | 10     | 95  | 142 | 2   | ○               | -  |
| 1181299Z9        | -           | HBDPCE/W 2 08D 0830-142095            | 8,30                                      | 10     | 95  | 142 | 2   | ○               | -  |
| 1181300Z9        | -           | HBDPCE/W 2 08D 0840-142095            | 8,40                                      | 10     | 95  | 142 | 2   | ○               | -  |
| 1181301Z9        | -           | HBDPCE/W 2 08D 0850-142095            | 8,50                                      | 10     | 95  | 142 | 2   | ⊗               | -  |
| 1181302Z9        | -           | HBDPCE/W 2 08D 0860-142095            | 8,60                                      | 10     | 95  | 142 | 2   | ○               | -  |
| 1181303Z9        | -           | HBDPCE/W 2 08D 0870-142095            | 8,70                                      | 10     | 95  | 142 | 2   | ⊗               | -  |
| 1181304Z9        | -           | HBDPCE/W 2 08D 0880-142095            | 8,80                                      | 10     | 95  | 142 | 2   | ⊗               | -  |
| 1181305Z9        | -           | HBDPCE/W 2 08D 0890-142095            | 8,90                                      | 10     | 95  | 142 | 2   | ○               | -  |
| 1181306Z9        | -           | HBDPCE/W 2 08D 0900-142095            | 9,00                                      | 10     | 95  | 142 | 2   | ○               | -  |
| 1181307Z9        | -           | HBDPCE/W 2 08D 0910-142095            | 9,10                                      | 10     | 95  | 142 | 2   | ○               | -  |
| 1181308Z9        | -           | HBDPCE/W 2 08D 0920-142095            | 9,20                                      | 10     | 95  | 142 | 2   | ○               | -  |
| 1181309Z9        | -           | HBDPCE/W 2 08D 0930-142095            | 9,30                                      | 10     | 95  | 142 | 2   | ○               | -  |
| 1181310Z9        | -           | HBDPCE/W 2 08D 0940-142095            | 9,40                                      | 10     | 95  | 142 | 2   | ○               | -  |
| 1181311Z9        | -           | HBDPCE/W 2 08D 0950-142095            | 9,50                                      | 10     | 95  | 142 | 2   | ○               | -  |
| 1181312Z9        | -           | HBDPCE/W 2 08D 0960-142095            | 9,60                                      | 10     | 95  | 142 | 2   | ○               | -  |
| 1181313Z9        | -           | HBDPCE/W 2 08D 0970-142095            | 9,70                                      | 10     | 95  | 142 | 2   | ○               | -  |
| 1181314Z9        | -           | HBDPCE/W 2 08D 0980-142095            | 9,80                                      | 10     | 95  | 142 | 2   | ○               | -  |
| 1181315Z9        | -           | HBDPCE/W 2 08D 0990-142095            | 9,90                                      | 10     | 95  | 142 | 2   | ○               | -  |
| 1181316Z9        | -           | HBDPCE/W 2 08D 1000-142095            | 10,00                                     | 10     | 95  | 142 | 2   | ○               | -  |
| 1181317Z9        | -           | HBDPCE/W 2 08D 1010-162114            | 10,10                                     | 12     | 114 | 162 | 2   | ○               | -  |

⊗ Stock item | Produto de stock | Itens de stock

○ Available under request | Disponível sobre consulta | Disponible bajo consulta

Continue next page

## HBDPCE/W 2 08D

Solid carbide drills | Brocas de metal duro | Brocas en metal duro

| Order code       |             | Reference<br>Referência<br>Referencia | Dimensions   Dimensões   Dimensiones (mm) |       |     |     | NOF | Stock<br>PHU920 |    |
|------------------|-------------|---------------------------------------|---|-------|-----|-----|-----|-----------------|----|
| HA (Cylindrical) | HB (Weldon) |                                       | DC  | DONMS | LCF | OAL |     | HA              | HB |
| 1181318Z9        | -           | HBDPCE/W 2 08D 1020-162114            | 10,20                                     | 12    | 114 | 162 | 2   | ⊗               | -  |
| 1181319Z9        | -           | HBDPCE/W 2 08D 1030-162114            | 10,30                                     | 12    | 114 | 162 | 2   | ○               | -  |
| 1181320Z9        | -           | HBDPCE/W 2 08D 1040-162114            | 10,40                                     | 12    | 114 | 162 | 2   | ○               | -  |
| 1181321Z9        | -           | HBDPCE/W 2 08D 1050-162114            | 10,50                                     | 12    | 114 | 162 | 2   | ⊗               | -  |
| 1181322Z9        | -           | HBDPCE/W 2 08D 1060-162114            | 10,60                                     | 12    | 114 | 162 | 2   | ○               | -  |
| 1181323Z9        | -           | HBDPCE/W 2 08D 1070-162114            | 10,70                                     | 12    | 114 | 162 | 2   | ○               | -  |
| 1181324Z9        | -           | HBDPCE/W 2 08D 1080-162114            | 10,80                                     | 12    | 114 | 162 | 2   | ○               | -  |
| 1181325Z9        | -           | HBDPCE/W 2 08D 1090-162114            | 10,90                                     | 12    | 114 | 162 | 2   | ○               | -  |
| 1181326Z9        | -           | HBDPCE/W 2 08D 1100-162114            | 11,00                                     | 12    | 114 | 162 | 2   | ○               | -  |
| 1181327Z9        | -           | HBDPCE/W 2 08D 1110-162114            | 11,10                                     | 12    | 114 | 162 | 2   | ○               | -  |
| 1181328Z9        | -           | HBDPCE/W 2 08D 1120-162114            | 11,20                                     | 12    | 114 | 162 | 2   | ○               | -  |
| 1181329Z9        | -           | HBDPCE/W 2 08D 1130-162114            | 11,30                                     | 12    | 114 | 162 | 2   | ○               | -  |
| 1181330Z9        | -           | HBDPCE/W 2 08D 1140-162114            | 11,40                                     | 12    | 114 | 162 | 2   | ○               | -  |
| 1181331Z9        | -           | HBDPCE/W 2 08D 1150-162114            | 11,50                                     | 12    | 114 | 162 | 2   | ○               | -  |
| 1181332Z9        | -           | HBDPCE/W 2 08D 1160-162114            | 11,60                                     | 12    | 114 | 162 | 2   | ○               | -  |
| 1181333Z9        | -           | HBDPCE/W 2 08D 1170-162114            | 11,70                                     | 12    | 114 | 162 | 2   | ○               | -  |
| 1181334Z9        | -           | HBDPCE/W 2 08D 1180-162114            | 11,80                                     | 12    | 114 | 162 | 2   | ⊗               | -  |
| 1181335Z9        | -           | HBDPCE/W 2 08D 1190-162114            | 11,90                                     | 12    | 114 | 162 | 2   | ○               | -  |
| 1181336Z9        | -           | HBDPCE/W 2 08D 1200-162114            | 12,00                                     | 12    | 114 | 162 | 2   | ○               | -  |

⊗ Stock item | Produto de stock | Itens de stock

○ Available under request | Disponível sobre consulta | Disponible bajo consulta



|                |                   |
|----------------|-------------------|
| P              | K                 |
| HRC<br>≤<br>60 | IT8-9<br>IT class |

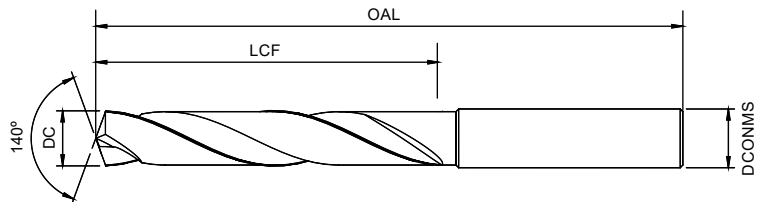

| Drill Dia. DC   | DC3,0  | 3,0<DC≤6,0 | 6,0<DC≤10,0 | 10,0<DC≤18,0 | 18,0<DC≤20,0 |
|-----------------|--------|------------|-------------|--------------|--------------|
| Hole Tolerances | +0,002 | +0,004     | +0,006      | +0,007       | +0,008       |
|                 | +0,012 | +0,016     | +0,021      | +0,025       | +0,028       |

| Order code       |             | Reference<br>Referência<br>Referencia | Dimensions   Dimensões   Dimensiones (mm) |        |     |     | NOF | Stock<br>PHU920 |    |
|------------------|-------------|---------------------------------------|---|--------|-----|-----|-----|-----------------|----|
| HA (Cylindrical) | HB (Weldon) |                                       | DC  | DCONMS | LCF | OAL |     | HA              | HB |
| 1180784Z9        | 1181859Z9   | HBDPUE/W 2 03D 0300-062020            | 3,00                                      | 6      | 20  | 62  | 2   | ☺               | ☺  |
| 1180852Z9        | 1181860Z9   | HBDPUE/W 2 03D 0310-062020            | 3,10                                      | 6      | 20  | 62  | 2   | ☺               | ☺  |
| 1180853Z9        | 1181861Z9   | HBDPUE/W 2 03D 0320-062020            | 3,20                                      | 6      | 20  | 62  | 2   | ☺               | ☺  |
| 1181790Z9        | 1181862Z9   | HBDPUE/W 2 03D 0325-062020            | 3,25                                      | 6      | 20  | 62  | 2   | ☺               | ☺  |
| 1180854Z9        | 1181863Z9   | HBDPUE/W 2 03D 0330-062020            | 3,30                                      | 6      | 20  | 62  | 2   | ☺               | ○  |
| 1180790Z9        | 1181864Z9   | HBDPUE/W 2 03D 0340-062020            | 3,40                                      | 6      | 20  | 62  | 2   | ☺               | ○  |
| 1180855Z9        | 1181865Z9   | HBDPUE/W 2 03D 0350-062020            | 3,50                                      | 6      | 20  | 62  | 2   | ☺               | ○  |
| 1180856Z9        | 1181866Z9   | HBDPUE/W 2 03D 0360-062020            | 3,60                                      | 6      | 20  | 62  | 2   | ☺               | ☺  |
| 1180857Z9        | 1181867Z9   | HBDPUE/W 2 03D 0370-062020            | 3,70                                      | 6      | 20  | 62  | 2   | ☺               | ☺  |
| 1180858Z9        | 1181868Z9   | HBDPUE/W 2 03D 0380-066024            | 3,80                                      | 6      | 24  | 66  | 2   | ☺               | ○  |
| 1180859Z9        | 1181869Z9   | HBDPUE/W 2 03D 0390-066024            | 3,90                                      | 6      | 24  | 66  | 2   | ☺               | ○  |
| 1180860Z9        | 1181870Z9   | HBDPUE/W 2 03D 0400-066024            | 4,00                                      | 6      | 24  | 66  | 2   | ☺               | ☺  |
| 1180861Z9        | 1181871Z9   | HBDPUE/W 2 03D 0410-066024            | 4,10                                      | 6      | 24  | 66  | 2   | ☺               | ☺  |
| 1180862Z9        | 1181872Z9   | HBDPUE/W 2 03D 0420-066024            | 4,20                                      | 6      | 24  | 66  | 2   | ☺               | ☺  |
| 1180863Z9        | 1181873Z9   | HBDPUE/W 2 03D 0430-066024            | 4,30                                      | 6      | 24  | 66  | 2   | ☺               | ☺  |
| 1180864Z9        | 1181874Z9   | HBDPUE/W 2 03D 0440-066024            | 4,40                                      | 6      | 24  | 66  | 2   | ☺               | ☺  |
| 1180865Z9        | 1181875Z9   | HBDPUE/W 2 03D 0450-066024            | 4,50                                      | 6      | 24  | 66  | 2   | ☺               | ○  |
| 1180866Z9        | 1181876Z9   | HBDPUE/W 2 03D 0460-066024            | 4,60                                      | 6      | 24  | 66  | 2   | ☺               | ○  |
| 1181792Z9        | 1181877Z9   | HBDPUE/W 2 03D 0465-066024            | 4,65                                      | 6      | 24  | 66  | 2   | ○               | ☺  |
| 1180867Z9        | 1181878Z9   | HBDPUE/W 2 03D 0470-066024            | 4,70                                      | 6      | 24  | 66  | 2   | ☺               | ○  |
| 1180868Z9        | 1181879Z9   | HBDPUE/W 2 03D 0480-066028            | 4,80                                      | 6      | 28  | 66  | 2   | ☺               | ☺  |
| 1180869Z9        | 1181880Z9   | HBDPUE/W 2 03D 0490-066028            | 4,90                                      | 6      | 28  | 66  | 2   | ☺               | ☺  |
| 1180870Z9        | 1181881Z9   | HBDPUE/W 2 03D 0500-066028            | 5,00                                      | 6      | 28  | 66  | 2   | ☺               | ○  |
| 1180871Z9        | 1181882Z9   | HBDPUE/W 2 03D 0510-066028            | 5,10                                      | 6      | 28  | 66  | 2   | ☺               | ☺  |
| 1180872Z9        | 1181883Z9   | HBDPUE/W 2 03D 0520-066028            | 5,20                                      | 6      | 28  | 66  | 2   | ☺               | ○  |
| 1180873Z9        | 1181884Z9   | HBDPUE/W 2 03D 0530-066028            | 5,30                                      | 6      | 28  | 66  | 2   | ☺               | ○  |

☺ Stock item | Produto de stock | Itens de stock

○ Available under request | Disponível sobre consulta | Disponible bajo consulta

Continue next page

## HBDPUE/W 2 03D

Solid carbide drills | Brocas de metal duro | Brocas en metal duro

| Order code       |             | Reference<br>Referência<br>Referencia | Dimensions   Dimensões   Dimensiones (mm) |        |     |     | NOF | Stock<br>PHU920 |    |
|------------------|-------------|---------------------------------------|---|--------|-----|-----|-----|-----------------|----|
| HA (Cylindrical) | HB (Weldon) |                                       | DC  | DCONMS | LCF | OAL |     | HA              | HB |
| 1180874Z9        | 1181885Z9   | HBDPUE/W 2 03D 0540-066028            | 5,40                                      | 6      | 28  | 66  | 2   | ☉               | ☉  |
| 1180875Z9        | 1181886Z9   | HBDPUE/W 2 03D 0550-066028            | 5,50                                      | 6      | 28  | 66  | 2   | ☉               | ○  |
| 1181794Z9        | 1181887Z9   | HBDPUE/W 2 03D 0555-066028            | 5,55                                      | 6      | 28  | 66  | 2   | ☉               | ☉  |
| 1180791Z9        | 1181888Z9   | HBDPUE/W 2 03D 0560-066028            | 5,60                                      | 6      | 28  | 66  | 2   | ☉               | ☉  |
| 1180876Z9        | 1181889Z9   | HBDPUE/W 2 03D 0570-066028            | 5,70                                      | 6      | 28  | 66  | 2   | ☉               | ☉  |
| 1180877Z9        | 1181890Z9   | HBDPUE/W 2 03D 0580-066028            | 5,80                                      | 6      | 28  | 66  | 2   | ☉               | ☉  |
| 1180878Z9        | 1181891Z9   | HBDPUE/W 2 03D 0590-066028            | 5,90                                      | 6      | 28  | 66  | 2   | ☉               | ○  |
| 1180879Z9        | 1181892Z9   | HBDPUE/W 2 03D 0600-066028            | 6,00                                      | 6      | 28  | 66  | 2   | ☉               | ☉  |
| 1180880Z9        | 1181893Z9   | HBDPUE/W 2 03D 0610-079034            | 6,10                                      | 8      | 34  | 79  | 2   | ☉               | ☉  |
| 1180881Z9        | 1181894Z9   | HBDPUE/W 2 03D 0620-079034            | 6,20                                      | 8      | 34  | 79  | 2   | ☉               | ○  |
| 1180882Z9        | 1181895Z9   | HBDPUE/W 2 03D 0630-079034            | 6,30                                      | 8      | 34  | 79  | 2   | ☉               | ○  |
| 1180883Z9        | 1181896Z9   | HBDPUE/W 2 03D 0640-079034            | 6,40                                      | 8      | 34  | 79  | 2   | ☉               | ○  |
| 1180884Z9        | 1181897Z9   | HBDPUE/W 2 03D 0650-079034            | 6,50                                      | 8      | 34  | 79  | 2   | ☉               | ☉  |
| 1180885Z9        | 1181898Z9   | HBDPUE/W 2 03D 0660-079034            | 6,60                                      | 8      | 34  | 79  | 2   | ☉               | ○  |
| 1180886Z9        | 1181899Z9   | HBDPUE/W 2 03D 0670-079034            | 6,70                                      | 8      | 34  | 79  | 2   | ☉               | ☉  |
| 1180887Z9        | 1181900Z9   | HBDPUE/W 2 03D 0680-079034            | 6,80                                      | 8      | 34  | 79  | 2   | ☉               | ○  |
| 1180888Z9        | 1181901Z9   | HBDPUE/W 2 03D 0690-079034            | 6,90                                      | 8      | 34  | 79  | 2   | ☉               | ○  |
| 1180889Z9        | 1181902Z9   | HBDPUE/W 2 03D 0700-079034            | 7,00                                      | 8      | 34  | 79  | 2   | ☉               | ☉  |
| 1180890Z9        | 1181903Z9   | HBDPUE/W 2 03D 0710-079041            | 7,10                                      | 8      | 41  | 79  | 2   | ☉               | ○  |
| 1180891Z9        | 1181904Z9   | HBDPUE/W 2 03D 0720-079041            | 7,20                                      | 8      | 41  | 79  | 2   | ☉               | ☉  |
| 1180892Z9        | 1181905Z9   | HBDPUE/W 2 03D 0730-079041            | 7,30                                      | 8      | 41  | 79  | 2   | ☉               | ☉  |
| 1180893Z9        | 1181906Z9   | HBDPUE/W 2 03D 0740-079041            | 7,40                                      | 8      | 41  | 79  | 2   | ☉               | ○  |
| 1180894Z9        | 1181907Z9   | HBDPUE/W 2 03D 0750-079041            | 7,50                                      | 8      | 41  | 79  | 2   | ☉               | ○  |
| 1180895Z9        | 1181908Z9   | HBDPUE/W 2 03D 0760-079041            | 7,60                                      | 8      | 41  | 79  | 2   | ☉               | ○  |
| 1180896Z9        | 1181909Z9   | HBDPUE/W 2 03D 0770-079041            | 7,70                                      | 8      | 41  | 79  | 2   | ☉               | ☉  |
| 1180897Z9        | 1181910Z9   | HBDPUE/W 2 03D 0780-079041            | 7,80                                      | 8      | 41  | 79  | 2   | ☉               | ☉  |
| 1180898Z9        | 1181911Z9   | HBDPUE/W 2 03D 0790-079041            | 7,90                                      | 8      | 41  | 79  | 2   | ☉               | ☉  |
| 1180899Z9        | 1181912Z9   | HBDPUE/W 2 03D 0800-079041            | 8,00                                      | 8      | 41  | 79  | 2   | ☉               | ☉  |
| 1180900Z9        | 1181913Z9   | HBDPUE/W 2 03D 0810-089047            | 8,10                                      | 10     | 47  | 89  | 2   | ☉               | ☉  |
| 1180901Z9        | 1181914Z9   | HBDPUE/W 2 03D 0820-089047            | 8,20                                      | 10     | 47  | 89  | 2   | ☉               | ○  |
| 1180902Z9        | 1181915Z9   | HBDPUE/W 2 03D 0830-089047            | 8,30                                      | 10     | 47  | 89  | 2   | ☉               | ○  |
| 1180903Z9        | 1181916Z9   | HBDPUE/W 2 03D 0840-089047            | 8,40                                      | 10     | 47  | 89  | 2   | ☉               | ☉  |
| 1180904Z9        | 1181917Z9   | HBDPUE/W 2 03D 0850-089047            | 8,50                                      | 10     | 47  | 89  | 2   | ☉               | ○  |
| 1180905Z9        | 1181918Z9   | HBDPUE/W 2 03D 0860-089047            | 8,60                                      | 10     | 47  | 89  | 2   | ☉               | ☉  |
| 1180906Z9        | 1181919Z9   | HBDPUE/W 2 03D 0870-089047            | 8,70                                      | 10     | 47  | 89  | 2   | ☉               | ○  |
| 1180907Z9        | 1181920Z9   | HBDPUE/W 2 03D 0880-089047            | 8,80                                      | 10     | 47  | 89  | 2   | ☉               | ○  |
| 1180908Z9        | 1181921Z9   | HBDPUE/W 2 03D 0890-089047            | 8,90                                      | 10     | 47  | 89  | 2   | ○               | ☉  |
| 1180909Z9        | 1181922Z9   | HBDPUE/W 2 03D 0900-089047            | 9,00                                      | 10     | 47  | 89  | 2   | ☉               | ☉  |
| 1180910Z9        | 1181923Z9   | HBDPUE/W 2 03D 0910-089047            | 9,10                                      | 10     | 47  | 89  | 2   | ☉               | ○  |
| 1180911Z9        | 1181924Z9   | HBDPUE/W 2 03D 0920-089047            | 9,20                                      | 10     | 47  | 89  | 2   | ☉               | ☉  |
| 1180912Z9        | 1181925Z9   | HBDPUE/W 2 03D 0930-089047            | 9,30                                      | 10     | 47  | 89  | 2   | ☉               | ☉  |
| 1180913Z9        | 1181926Z9   | HBDPUE/W 2 03D 0940-089047            | 9,40                                      | 10     | 47  | 89  | 2   | ☉               | ☉  |
| 1180914Z9        | 1181927Z9   | HBDPUE/W 2 03D 0950-089047            | 9,50                                      | 10     | 47  | 89  | 2   | ☉               | ○  |
| 1180915Z9        | 1181928Z9   | HBDPUE/W 2 03D 0960-089047            | 9,60                                      | 10     | 47  | 89  | 2   | ☉               | ☉  |
| 1180916Z9        | 1181929Z9   | HBDPUE/W 2 03D 0970-089047            | 9,70                                      | 10     | 47  | 89  | 2   | ☉               | ☉  |
| 1180917Z9        | 1181930Z9   | HBDPUE/W 2 03D 0980-089047            | 9,80                                      | 10     | 47  | 89  | 2   | ☉               | ☉  |
| 1180918Z9        | 1181931Z9   | HBDPUE/W 2 03D 0990-089047            | 9,90                                      | 10     | 47  | 89  | 2   | ☉               | ○  |
| 1180919Z9        | 1181932Z9   | HBDPUE/W 2 03D 1000-089047            | 10,00                                     | 10     | 47  | 89  | 2   | ☉               | ☉  |

☉ Stock item | Produto de stock | Itens de stock

○ Available under request | Disponível sobre consulta | Disponible bajo consulta

Continue next page

# HBDPUE/W 2 03D

Solid carbide drills | Brocas de metal duro | Brocas en metal duro

| Order code       |             | Reference<br>Referência<br>Referencia | Dimensions   Dimensões   Dimensiones (mm) |        |     |     | NOF | Stock<br>PHU920 |    |
|------------------|-------------|---------------------------------------|---|--------|-----|-----|-----|-----------------|----|
| HA (Cylindrical) | HB (Weldon) |                                       | DC  | DCONMS | LCF | OAL |     | HA              | HB |
| 1180920Z9        | -           | HBDPUE/W 2 03D 1010-102055            | 10,10                                     | 12     | 55  | 102 | 2   | ⊗               | -  |
| 1180921Z9        | 1181933Z9   | HBDPUE/W 2 03D 1020-102055            | 10,20                                     | 12     | 55  | 102 | 2   | ⊗               | ⊗  |
| 1180922Z9        | 1181934Z9   | HBDPUE/W 2 03D 1030-102055            | 10,30                                     | 12     | 55  | 102 | 2   | ⊗               | ○  |
| 1180923Z9        | -           | HBDPUE/W 2 03D 1040-102055            | 10,40                                     | 12     | 55  | 102 | 2   | ⊗               | -  |
| 1180924Z9        | 1181935Z9   | HBDPUE/W 2 03D 1050-102055            | 10,50                                     | 12     | 55  | 102 | 2   | ⊗               | ⊗  |
| 1180925Z9        | -           | HBDPUE/W 2 03D 1060-102055            | 10,60                                     | 12     | 55  | 102 | 2   | ○               | -  |
| 1180926Z9        | -           | HBDPUE/W 2 03D 1070-102055            | 10,70                                     | 12     | 55  | 102 | 2   | ○               | -  |
| 1180927Z9        | 1181936Z9   | HBDPUE/W 2 03D 1080-102055            | 10,80                                     | 12     | 55  | 102 | 2   | ⊗               | ⊗  |
| 1180928Z9        | -           | HBDPUE/W 2 03D 1090-102055            | 10,90                                     | 12     | 55  | 102 | 2   | ○               | -  |
| 1180929Z9        | 1181937Z9   | HBDPUE/W 2 03D 1100-102055            | 11,00                                     | 12     | 55  | 102 | 2   | ⊗               | ⊗  |
| 1180930Z9        | -           | HBDPUE/W 2 03D 1110-102055            | 11,10                                     | 12     | 55  | 102 | 2   | ⊗               | -  |
| 1180931Z9        | 1181938Z9   | HBDPUE/W 2 03D 1120-102055            | 11,20                                     | 12     | 55  | 102 | 2   | ⊗               | ⊗  |
| 1180932Z9        | -           | HBDPUE/W 2 03D 1130-102055            | 11,30                                     | 12     | 55  | 102 | 2   | ○               | -  |
| 1180933Z9        | -           | HBDPUE/W 2 03D 1140-102055            | 11,40                                     | 12     | 55  | 102 | 2   | ○               | -  |
| 1180934Z9        | 1181939Z9   | HBDPUE/W 2 03D 1150-102055            | 11,50                                     | 12     | 55  | 102 | 2   | ⊗               | ⊗  |
| 1180935Z9        | -           | HBDPUE/W 2 03D 1160-102055            | 11,60                                     | 12     | 55  | 102 | 2   | ○               | -  |
| 1180936Z9        | -           | HBDPUE/W 2 03D 1170-102055            | 11,70                                     | 12     | 55  | 102 | 2   | ○               | -  |
| 1180937Z9        | 1181940Z9   | HBDPUE/W 2 03D 1180-102055            | 11,80                                     | 12     | 55  | 102 | 2   | ⊗               | ⊗  |
| 1180938Z9        | -           | HBDPUE/W 2 03D 1190-102055            | 11,90                                     | 12     | 55  | 102 | 2   | ⊗               | -  |
| 1180939Z9        | 1181941Z9   | HBDPUE/W 2 03D 1200-102055            | 12,00                                     | 12     | 55  | 102 | 2   | ⊗               | ⊗  |
| 1180940Z9        | 1181942Z9   | HBDPUE/W 2 03D 1250-107060            | 12,50                                     | 14     | 60  | 107 | 2   | ⊗               | ○  |
| 1181769Z9        | 1181943Z9   | HBDPUE/W 2 03D 1280-107060            | 12,80                                     | 14     | 60  | 107 | 2   | ⊗               | ⊗  |
| 1180941Z9        | 1181944Z9   | HBDPUE/W 2 03D 1300-107060            | 13,00                                     | 14     | 60  | 107 | 2   | ⊗               | ⊗  |
| 1182437Z9        | -           | HBDPUE/W 2 03D 1310-107060            | 13,10                                     | 14     | 60  | 107 | 2   | ○               | -  |
| 1182400Z9        | 1182401Z9   | HBDPUE/W 2 03D 1320-107060            | 13,20                                     | 14     | 60  | 107 | 2   | ⊗               | ○  |
| 1180942Z9        | 1181945Z9   | HBDPUE/W 2 03D 1350-107060            | 13,50                                     | 14     | 60  | 107 | 2   | ⊗               | ○  |
| 1181771Z9        | 1181946Z9   | HBDPUE/W 2 03D 1380-107060            | 13,80                                     | 14     | 60  | 107 | 2   | ⊗               | ⊗  |
| 1180943Z9        | 1181947Z9   | HBDPUE/W 2 03D 1400-107060            | 14,00                                     | 14     | 60  | 107 | 2   | ⊗               | ⊗  |
| 1181773Z9        | 1181948Z9   | HBDPUE/W 2 03D 1420-115065            | 14,20                                     | 16     | 65  | 115 | 2   | ⊗               | ⊗  |
| 1180944Z9        | 1181949Z9   | HBDPUE/W 2 03D 1450-115065            | 14,50                                     | 16     | 65  | 115 | 2   | ⊗               | ○  |
| 1181775Z9        | 1181950Z9   | HBDPUE/W 2 03D 1480-115065            | 14,80                                     | 16     | 65  | 115 | 2   | ⊗               | ⊗  |
| 1180945Z9        | 1181951Z9   | HBDPUE/W 2 03D 1500-115065            | 15,00                                     | 16     | 65  | 115 | 2   | ⊗               | ○  |
| 1180946Z9        | 1181952Z9   | HBDPUE/W 2 03D 1550-115065            | 15,50                                     | 16     | 65  | 115 | 2   | ⊗               | ⊗  |
| 1181777Z9        | 1181953Z9   | HBDPUE/W 2 03D 1580-115065            | 15,80                                     | 16     | 65  | 115 | 2   | ⊗               | ⊗  |
| 1180947Z9        | 1181954Z9   | HBDPUE/W 2 03D 1600-115065            | 16,00                                     | 16     | 65  | 115 | 2   | ⊗               | ⊗  |
| 1180948Z9        | 1181955Z9   | HBDPUE/W 2 03D 1650-123073            | 16,50                                     | 18     | 73  | 123 | 2   | ⊗               | ○  |
| 1180949Z9        | 1181956Z9   | HBDPUE/W 2 03D 1700-123073            | 17,00                                     | 18     | 73  | 123 | 2   | ⊗               | ⊗  |
| 1180950Z9        | 1181957Z9   | HBDPUE/W 2 03D 1750-123073            | 17,50                                     | 18     | 73  | 123 | 2   | ⊗               | ○  |
| 1180951Z9        | 1181958Z9   | HBDPUE/W 2 03D 1800-123073            | 18,00                                     | 18     | 73  | 123 | 2   | ⊗               | ⊗  |
| 1180952Z9        | 1181959Z9   | HBDPUE/W 2 03D 1850-131079            | 18,50                                     | 20     | 79  | 131 | 2   | ⊗               | ⊗  |
| 1180953Z9        | 1181960Z9   | HBDPUE/W 2 03D 1900-131079            | 19,00                                     | 20     | 79  | 131 | 2   | ⊗               | ⊗  |
| 1180954Z9        | 1181961Z9   | HBDPUE/W 2 03D 1950-131079            | 19,50                                     | 20     | 79  | 131 | 2   | ⊗               | ⊗  |
| 1180955Z9        | 1181962Z9   | HBDPUE/W 2 03D 2000-131079            | 20,00                                     | 20     | 79  | 131 | 2   | ⊗               | ⊗  |

⊗ Stock item | Produto de stock | Itens de stock

○ Available under request | Disponível sobre consulta | Disponible bajo consulta



|                |                   |
|----------------|-------------------|
| P              | K                 |
| HRC<br>≤<br>60 | IT8-9<br>IT class |

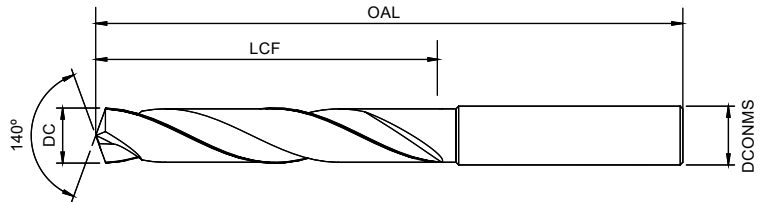

| Drill Dia. DC   | DC3,0  | 3,0<DC≤6,0 | 6,0<DC≤10,0 | 10,0<DC≤18,0 | 18,0<DC≤20,0 |
|-----------------|--------|------------|-------------|--------------|--------------|
| Hole Tolerances | +0,002 | +0,004     | +0,006      | +0,007       | +0,008       |
|                 | +0,012 | +0,016     | +0,021      | +0,025       | +0,028       |

| Order code       |             | Reference<br>Referência<br>Referencia | Dimensions   Dimensões   Dimensiones (mm) |        |     |     | NOF | Stock<br>PHU920 |    |
|------------------|-------------|---------------------------------------|---|--------|-----|-----|-----|-----------------|----|
| HA (Cylindrical) | HB (Weldon) |                                       | DC  | DCONMS | LCF | OAL |     | HA              | HB |
| 1180793Z9        | -           | HBDPUE/W 2 05D 0300-066028            | 3,00                                      | 6      | 28  | 66  | 2   | ⊗               | -  |
| 1180794Z9        | -           | HBDPUE/W 2 05D 0310-066028            | 3,10                                      | 6      | 28  | 66  | 2   | ⊗               | -  |
| 1181062Z9        | -           | HBDPUE/W 2 05D 0320-066028            | 3,20                                      | 6      | 28  | 66  | 2   | ⊗               | -  |
| 1181063Z9        | -           | HBDPUE/W 2 05D 0330-066028            | 3,30                                      | 6      | 28  | 66  | 2   | ⊗               | -  |
| 1180789Z9        | -           | HBDPUE/W 2 05D 0340-066028            | 3,40                                      | 6      | 28  | 66  | 2   | ⊗               | -  |
| 1181064Z9        | -           | HBDPUE/W 2 05D 0350-066028            | 3,50                                      | 6      | 28  | 66  | 2   | ○               | -  |
| 1181065Z9        | -           | HBDPUE/W 2 05D 0360-066028            | 3,60                                      | 6      | 28  | 66  | 2   | ○               | -  |
| 1181066Z9        | -           | HBDPUE/W 2 05D 0370-066028            | 3,70                                      | 6      | 28  | 66  | 2   | ○               | -  |
| 1181067Z9        | -           | HBDPUE/W 2 05D 0380-074036            | 3,80                                      | 6      | 36  | 74  | 2   | ⊗               | -  |
| 1180795Z9        | -           | HBDPUE/W 2 05D 0390-074036            | 3,90                                      | 6      | 36  | 74  | 2   | ○               | -  |
| 1181068Z9        | -           | HBDPUE/W 2 05D 0400-074036            | 4,00                                      | 6      | 36  | 74  | 2   | ⊗               | -  |
| 1181069Z9        | -           | HBDPUE/W 2 05D 0410-074036            | 4,10                                      | 6      | 36  | 74  | 2   | ⊗               | -  |
| 1180785Z9        | -           | HBDPUE/W 2 05D 0420-074036            | 4,20                                      | 6      | 36  | 74  | 2   | ⊗               | -  |
| 1181070Z9        | -           | HBDPUE/W 2 05D 0430-074036            | 4,30                                      | 6      | 36  | 74  | 2   | ⊗               | -  |
| 1181071Z9        | -           | HBDPUE/W 2 05D 0440-074036            | 4,40                                      | 6      | 36  | 74  | 2   | ○               | -  |
| 1181072Z9        | -           | HBDPUE/W 2 05D 0450-074036            | 4,50                                      | 6      | 36  | 74  | 2   | ⊗               | -  |
| 1181073Z9        | -           | HBDPUE/W 2 05D 0460-074036            | 4,60                                      | 6      | 36  | 74  | 2   | ○               | -  |
| 1181534Z9        | -           | HBDPUE/W 2 05D 0465-074036            | 4,65                                      | 6      | 36  | 74  | 2   | ○               | -  |
| 1180786Z9        | -           | HBDPUE/W 2 05D 0470-074036            | 4,70                                      | 6      | 36  | 74  | 2   | ⊗               | -  |
| 1181074Z9        | -           | HBDPUE/W 2 05D 0480-082044            | 4,80                                      | 6      | 44  | 82  | 2   | ⊗               | -  |
| 1181075Z9        | -           | HBDPUE/W 2 05D 0490-082044            | 4,90                                      | 6      | 44  | 82  | 2   | ○               | -  |
| 1180782Z9        | -           | HBDPUE/W 2 05D 0500-082044            | 5,00                                      | 6      | 44  | 82  | 2   | ⊗               | -  |
| 1181076Z9        | -           | HBDPUE/W 2 05D 0510-082044            | 5,10                                      | 6      | 44  | 82  | 2   | ⊗               | -  |
| 1181077Z9        | -           | HBDPUE/W 2 05D 0520-082044            | 5,20                                      | 6      | 44  | 82  | 2   | ⊗               | -  |
| 1181078Z9        | -           | HBDPUE/W 2 05D 0530-082044            | 5,30                                      | 6      | 44  | 82  | 2   | ○               | -  |
| 1181079Z9        | -           | HBDPUE/W 2 05D 0540-082044            | 5,40                                      | 6      | 44  | 82  | 2   | ○               | -  |

⊗ Stock item | Produto de stock | Itens de stock

○ Available under request | Disponível sobre consulta | Disponible bajo consulta

Continue next page

# HBDPUE/W 2 05D

Solid carbide drills | Brocas de metal duro | Brocas en metal duro

| Order code       |             | Reference<br>Referência<br>Referencia | Dimensions   Dimensões   Dimensiones (mm) |        |     |     | NOF | Stock<br>PHU920 |    |
|------------------|-------------|---------------------------------------|---|--------|-----|-----|-----|-----------------|----|
| HA (Cylindrical) | HB (Weldon) |                                       | DC  | DCONMS | LCF | OAL |     | HA              | HB |
| 1181080Z9        | -           | HBDPUE/W 2 05D 0550-082044            | 5,50                                      | 6      | 44  | 82  | 2   | ○               | -  |
| 1181081Z9        | -           | HBDPUE/W 2 05D 0560-082044            | 5,60                                      | 6      | 44  | 82  | 2   | ⊗               | -  |
| 1181082Z9        | -           | HBDPUE/W 2 05D 0570-082044            | 5,70                                      | 6      | 44  | 82  | 2   | ○               | -  |
| 1181083Z9        | -           | HBDPUE/W 2 05D 0580-082044            | 5,80                                      | 6      | 44  | 82  | 2   | ⊗               | -  |
| 1181084Z9        | -           | HBDPUE/W 2 05D 0590-082044            | 5,90                                      | 6      | 44  | 82  | 2   | ○               | -  |
| 1181085Z9        | -           | HBDPUE/W 2 05D 0600-082044            | 6,00                                      | 6      | 44  | 82  | 2   | ⊗               | -  |
| 1181086Z9        | -           | HBDPUE/W 2 05D 0610-091053            | 6,10                                      | 8      | 53  | 91  | 2   | ○               | -  |
| 1181087Z9        | -           | HBDPUE/W 2 05D 0620-091053            | 6,20                                      | 8      | 53  | 91  | 2   | ○               | -  |
| 1181088Z9        | -           | HBDPUE/W 2 05D 0630-091053            | 6,30                                      | 8      | 53  | 91  | 2   | ○               | -  |
| 1181089Z9        | -           | HBDPUE/W 2 05D 0640-091053            | 6,40                                      | 8      | 53  | 91  | 2   | ⊗               | -  |
| 1181090Z9        | -           | HBDPUE/W 2 05D 0650-091053            | 6,50                                      | 8      | 53  | 91  | 2   | ⊗               | -  |
| 1181091Z9        | -           | HBDPUE/W 2 05D 0660-091053            | 6,60                                      | 8      | 53  | 91  | 2   | ○               | -  |
| 1181092Z9        | -           | HBDPUE/W 2 05D 0670-091053            | 6,70                                      | 8      | 53  | 91  | 2   | ○               | -  |
| 1180781Z9        | -           | HBDPUE/W 2 05D 0680-091053            | 6,80                                      | 8      | 53  | 91  | 2   | ⊗               | -  |
| 1181093Z9        | -           | HBDPUE/W 2 05D 0690-091053            | 6,90                                      | 8      | 53  | 91  | 2   | ⊗               | -  |
| 1181094Z9        | -           | HBDPUE/W 2 05D 0700-091053            | 7,00                                      | 8      | 53  | 91  | 2   | ⊗               | -  |
| 1181095Z9        | -           | HBDPUE/W 2 05D 0710-091053            | 7,10                                      | 8      | 53  | 91  | 2   | ○               | -  |
| 1181096Z9        | -           | HBDPUE/W 2 05D 0720-091053            | 7,20                                      | 8      | 53  | 91  | 2   | ⊗               | -  |
| 1181097Z9        | -           | HBDPUE/W 2 05D 0730-091053            | 7,30                                      | 8      | 53  | 91  | 2   | ○               | -  |
| 1181098Z9        | -           | HBDPUE/W 2 05D 0740-091053            | 7,40                                      | 8      | 53  | 91  | 2   | ○               | -  |
| 1181099Z9        | -           | HBDPUE/W 2 05D 0750-091053            | 7,50                                      | 8      | 53  | 91  | 2   | ○               | -  |
| 1181100Z9        | -           | HBDPUE/W 2 05D 0760-091053            | 7,60                                      | 8      | 53  | 91  | 2   | ○               | -  |
| 1181101Z9        | -           | HBDPUE/W 2 05D 0770-091053            | 7,70                                      | 8      | 53  | 91  | 2   | ○               | -  |
| 1181102Z9        | -           | HBDPUE/W 2 05D 0780-091053            | 7,80                                      | 8      | 53  | 91  | 2   | ⊗               | -  |
| 1181103Z9        | -           | HBDPUE/W 2 05D 0790-091053            | 7,90                                      | 8      | 53  | 91  | 2   | ○               | -  |
| 1181104Z9        | -           | HBDPUE/W 2 05D 0800-091053            | 8,00                                      | 8      | 53  | 91  | 2   | ○               | -  |
| 1181105Z9        | -           | HBDPUE/W 2 05D 0810-103061            | 8,10                                      | 10     | 61  | 103 | 2   | ○               | -  |
| 1181106Z9        | -           | HBDPUE/W 2 05D 0820-103061            | 8,20                                      | 10     | 61  | 103 | 2   | ○               | -  |
| 1181107Z9        | -           | HBDPUE/W 2 05D 0830-103061            | 8,30                                      | 10     | 61  | 103 | 2   | ⊗               | -  |
| 1181108Z9        | -           | HBDPUE/W 2 05D 0840-103061            | 8,40                                      | 10     | 61  | 103 | 2   | ○               | -  |
| 1181109Z9        | -           | HBDPUE/W 2 05D 0850-103061            | 8,50                                      | 10     | 61  | 103 | 2   | ⊗               | -  |
| 1181110Z9        | -           | HBDPUE/W 2 05D 0860-103061            | 8,60                                      | 10     | 61  | 103 | 2   | ○               | -  |
| 1181111Z9        | -           | HBDPUE/W 2 05D 0870-103061            | 8,70                                      | 10     | 61  | 103 | 2   | ○               | -  |
| 1181112Z9        | -           | HBDPUE/W 2 05D 0880-103061            | 8,80                                      | 10     | 61  | 103 | 2   | ○               | -  |
| 1181113Z9        | -           | HBDPUE/W 2 05D 0890-103061            | 8,90                                      | 10     | 61  | 103 | 2   | ○               | -  |
| 1181114Z9        | -           | HBDPUE/W 2 05D 0900-103061            | 9,00                                      | 10     | 61  | 103 | 2   | ⊗               | -  |
| 1181115Z9        | -           | HBDPUE/W 2 05D 0910-103061            | 9,10                                      | 10     | 61  | 103 | 2   | ○               | -  |
| 1181116Z9        | -           | HBDPUE/W 2 05D 0920-103061            | 9,20                                      | 10     | 61  | 103 | 2   | ○               | -  |
| 1181117Z9        | -           | HBDPUE/W 2 05D 0930-103061            | 9,30                                      | 10     | 61  | 103 | 2   | ○               | -  |
| 1181118Z9        | -           | HBDPUE/W 2 05D 0940-103061            | 9,40                                      | 10     | 61  | 103 | 2   | ○               | -  |
| 1181119Z9        | -           | HBDPUE/W 2 05D 0950-103061            | 9,50                                      | 10     | 61  | 103 | 2   | ⊗               | -  |
| 1181120Z9        | -           | HBDPUE/W 2 05D 0960-103061            | 9,60                                      | 10     | 61  | 103 | 2   | ○               | -  |
| 1181121Z9        | -           | HBDPUE/W 2 05D 0970-103061            | 9,70                                      | 10     | 61  | 103 | 2   | ○               | -  |
| 1181122Z9        | -           | HBDPUE/W 2 05D 0980-103061            | 9,80                                      | 10     | 61  | 103 | 2   | ⊗               | -  |
| 1181123Z9        | -           | HBDPUE/W 2 05D 0990-103061            | 9,90                                      | 10     | 61  | 103 | 2   | ○               | -  |
| 1181124Z9        | -           | HBDPUE/W 2 05D 1000-103061            | 10,00                                     | 10     | 61  | 103 | 2   | ○               | -  |
| 1181125Z9        | -           | HBDPUE/W 2 05D 1010-118071            | 10,10                                     | 12     | 71  | 118 | 2   | ○               | -  |
| 1181126Z9        | -           | HBDPUE/W 2 05D 1020-118071            | 10,20                                     | 12     | 71  | 118 | 2   | ⊗               | -  |

⊗ Stock item | Produto de stock | Itens de stock

○ Available under request | Disponível sobre consulta | Disponible bajo consulta

Continue next page

## HBDPUE/W 2 05D

Solid carbide drills | Brocas de metal duro | Brocas en metal duro

| Order code       |             | Reference<br>Referência<br>Referencia | Dimensions   Dimensões   Dimensiones (mm) |        |     |     | NOF | Stock<br>PHU920 |    |
|------------------|-------------|---------------------------------------|---|--------|-----|-----|-----|-----------------|----|
| HA (Cylindrical) | HB (Weldon) |                                       | DC  | DCONMS | LCF | OAL |     | HA              | HB |
| 1181127Z9        | -           | HBDPUE/W 2 05D 1030-118071            | 10,30                                     | 12     | 71  | 118 | 2   | ○               | -  |
| 1181128Z9        | -           | HBDPUE/W 2 05D 1040-118071            | 10,40                                     | 12     | 71  | 118 | 2   | ○               | -  |
| 1180796Z9        | -           | HBDPUE/W 2 05D 1050-118071            | 10,50                                     | 12     | 71  | 118 | 2   | ⊗               | -  |
| 1181129Z9        | -           | HBDPUE/W 2 05D 1060-118071            | 10,60                                     | 12     | 71  | 118 | 2   | ○               | -  |
| 1181130Z9        | -           | HBDPUE/W 2 05D 1070-118071            | 10,70                                     | 12     | 71  | 118 | 2   | ○               | -  |
| 1181131Z9        | -           | HBDPUE/W 2 05D 1080-118071            | 10,80                                     | 12     | 71  | 118 | 2   | ○               | -  |
| 1181132Z9        | -           | HBDPUE/W 2 05D 1090-118071            | 10,90                                     | 12     | 71  | 118 | 2   | ○               | -  |
| 1181133Z9        | -           | HBDPUE/W 2 05D 1100-118071            | 11,00                                     | 12     | 71  | 118 | 2   | ⊗               | -  |
| 1181134Z9        | -           | HBDPUE/W 2 05D 1110-118071            | 11,10                                     | 12     | 71  | 118 | 2   | ○               | -  |
| 1181135Z9        | -           | HBDPUE/W 2 05D 1120-118071            | 11,20                                     | 12     | 71  | 118 | 2   | ○               | -  |
| 1181136Z9        | -           | HBDPUE/W 2 05D 1130-118071            | 11,30                                     | 12     | 71  | 118 | 2   | ○               | -  |
| 1181137Z9        | -           | HBDPUE/W 2 05D 1140-118071            | 11,40                                     | 12     | 71  | 118 | 2   | ○               | -  |
| 1181138Z9        | -           | HBDPUE/W 2 05D 1150-118071            | 11,50                                     | 12     | 71  | 118 | 2   | ⊗               | -  |
| 1181139Z9        | -           | HBDPUE/W 2 05D 1160-118071            | 11,60                                     | 12     | 71  | 118 | 2   | ○               | -  |
| 1181140Z9        | -           | HBDPUE/W 2 05D 1170-118071            | 11,70                                     | 12     | 71  | 118 | 2   | ○               | -  |
| 1181141Z9        | -           | HBDPUE/W 2 05D 1180-118071            | 11,80                                     | 12     | 71  | 118 | 2   | ○               | -  |
| 1181142Z9        | -           | HBDPUE/W 2 05D 1190-118071            | 11,90                                     | 12     | 71  | 118 | 2   | ○               | -  |
| 1181143Z9        | -           | HBDPUE/W 2 05D 1200-118071            | 12,00                                     | 12     | 71  | 118 | 2   | ⊗               | -  |
| 1181144Z9        | -           | HBDPUE/W 2 05D 1250-124077            | 12,50                                     | 14     | 77  | 124 | 2   | ○               | -  |
| 1181145Z9        | -           | HBDPUE/W 2 05D 1300-124077            | 13,00                                     | 14     | 77  | 124 | 2   | ⊗               | -  |
| 1181146Z9        | -           | HBDPUE/W 2 05D 1350-124077            | 13,50                                     | 14     | 77  | 124 | 2   | ○               | -  |
| 1181147Z9        | -           | HBDPUE/W 2 05D 1400-124077            | 14,00                                     | 14     | 77  | 124 | 2   | ⊗               | -  |
| 1181148Z9        | -           | HBDPUE/W 2 05D 1450-133083            | 14,50                                     | 16     | 83  | 133 | 2   | ⊗               | -  |
| 1181149Z9        | -           | HBDPUE/W 2 05D 1500-133083            | 15,00                                     | 16     | 83  | 133 | 2   | ○               | -  |
| 1181150Z9        | -           | HBDPUE/W 2 05D 1550-133083            | 15,50                                     | 16     | 83  | 133 | 2   | ○               | -  |
| 1181151Z9        | -           | HBDPUE/W 2 05D 1600-133083            | 16,00                                     | 16     | 83  | 133 | 2   | ○               | -  |
| 1181152Z9        | -           | HBDPUE/W 2 05D 1650-143093            | 16,50                                     | 18     | 93  | 143 | 2   | ○               | -  |
| 1181153Z9        | -           | HBDPUE/W 2 05D 1700-143093            | 17,00                                     | 18     | 93  | 143 | 2   | ○               | -  |
| 1181154Z9        | -           | HBDPUE/W 2 05D 1750-143093            | 17,50                                     | 18     | 93  | 143 | 2   | ○               | -  |
| 1181155Z9        | -           | HBDPUE/W 2 05D 1800-143093            | 18,00                                     | 18     | 93  | 143 | 2   | ○               | -  |
| 1181156Z9        | -           | HBDPUE/W 2 05D 1850-153101            | 18,50                                     | 20     | 101 | 153 | 2   | ○               | -  |
| 1181157Z9        | -           | HBDPUE/W 2 05D 1900-153101            | 19,00                                     | 20     | 101 | 153 | 2   | ○               | -  |
| 1181158Z9        | -           | HBDPUE/W 2 05D 1950-153101            | 19,50                                     | 20     | 101 | 153 | 2   | ○               | -  |
| 1181159Z9        | -           | HBDPUE/W 2 05D 2000-153101            | 20,00                                     | 20     | 101 | 153 | 2   | ○               | -  |

⊗ Stock item | Produto de stock | Itens de stock

○ Available under request | Disponível sobre consulta | Disponible bajo consulta

# SOLID CARBIDE DRILLS CUTTING PARAMETERS AND ADJUSTMENTS

Parâmetros de corte e ajustes | Condiciones de corte y ajustes

## RECOMMENDED SPEEDS AND FEEDS

| ISO | Material Group<br>Grupo Materiais<br>Grupo Materiales | Vc (m/min) | f (mm/rev) |           |           |           |
|-----|---|------------|------------|-----------|-----------|-----------|
|     |   |            | Ø3-8mm     | Ø8-12mm   | Ø12-16mm  | Ø16-20mm  |
| P   | Unalloyed steel (-0,25%)                              | 80-100     | 0,10-0,20  | 0,15-0,25 | 0,20-0,40 | 0,25-0,50 |
|     | Low-alloy steel (0,25%-)                              | 70-100     | 0,10-0,20  | 0,20-0,30 | 0,20-0,35 | 0,25-0,40 |
|     | High-alloy steel                                      | 40-70      | 0,08-0,15  | 0,12-0,22 | 0,20-0,40 | 0,25-0,40 |
| M   | Stainless steel                                       | 35-50      | 0,08-0,15  | 0,12-0,25 | 0,15-0,30 | 0,20-0,35 |
| K   | Maleable cast iron                                    | 70-100     | 0,10-0,30  | 0,20-0,40 | 0,25-0,40 | 0,25-0,50 |
|     | Grey cast iron  | 70-100     | 0,10-0,25  | 0,20-0,35 | 0,30-0,45 | 0,35-0,55 |

## COOLANT APPLICATION CHART

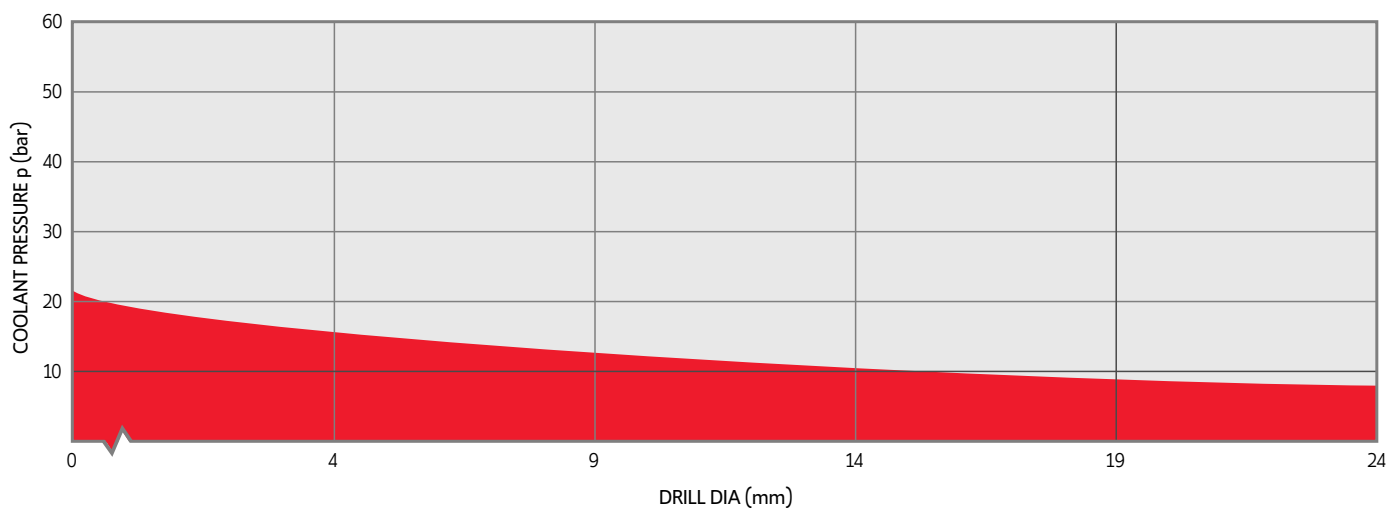

## LOOKING FOR MORE TROUBLESHOOTING?



Check the qrcode for more information